

MODEL	A	B	C	D
S09	51.30	11.40	15.75	26.77
S11	60.83	11.87	19.69	32.91
S13	70.51	14.03	24.80	41.94
S16	83.70	14.82	31.50	47.02
S20	100.63	27.68	39.37	56.89

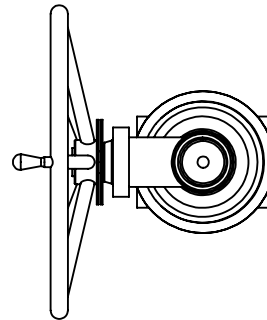
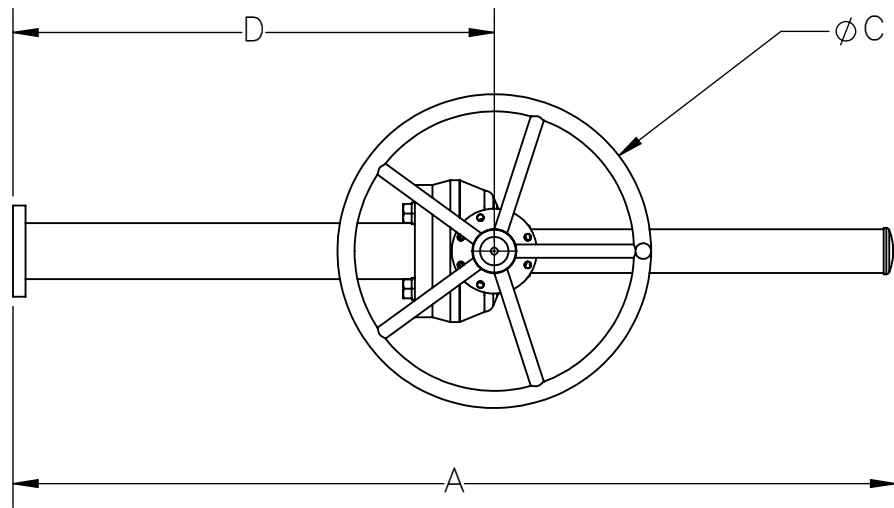
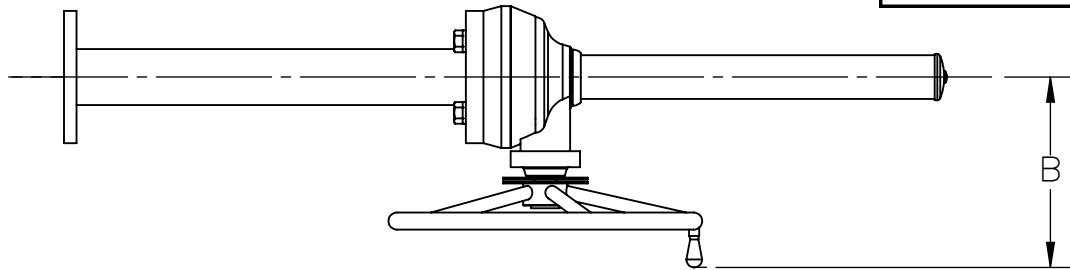

9955 INTERNATIONAL BLVD.
CINCINNATI, OHIO 45246
PHONE: (513) 247-5465
FAX: (513) 247-5462

DRAWN BY CHS

CHECKED BY CMB

RELEASED BY CMB

SHEET 1 of 1

DATE 03/11/19

DATE 03/11/19

DATE 03/11/19

MATERIAL

DO NOT SCALE DRAWING

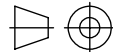

DESCRIPTION

THD DOUBLE ACTING JACKSCREW MODELS
S09 THRU S20

DRAWING NO.

P02931

REVISION

THE DESIGN AND DISCLOSURE CONTAINED IN THIS DRAWING WAS ORIGINATED BY, AND IS EXCLUSIVE PROPERTY OF A-T CONTROLS, INC. IT IS FURNISHED FOR VENDOR INFORMATION ONLY AND IS NOT AN AUTHORIZATION OR LICENSE TO MAKE THIS CONSTRUCTION OR TO FURNISH THIS INFORMATION TO OTHERS. ALL DRAWINGS MUST BE RETURNED TO A-T CONTROLS, INC. ON DEMAND. THIS DRAWING IS NOT TO BE REPRODUCED OR COPIED IN ANY FORM WITHOUT THE EXPRESS WRITTEN PERMISSION OF A-T CONTROLS, INC.