

The Triac TDC-100 is a high performance digital positioner intended to control AC actuators, providing 450 points of resolution with quarter turn actuators ranging from 2 sec to 120 sec and rated for 25% duty or more. The TDC-100 has many automatic advanced features that will enhance any actuator while making it easy to install and set up.

The simple three button control is used to configure all parameters the unit needs for a wide variety of applications, and allows the *open* and *closed* positions to be easily set for direct or reversing acting without any rewiring. The unit can be configured for various command types (4-20mA, 1-5V, 0-5V, 0-10V, or a digital command) and its default operation upon loss of command.

Various option modules are easily plugged into the unit, providing other features such as a position feedback signal (current or voltage), auxiliary switches, fault relay contact, or digital communications. A wide range of data is accessible through a digital communications

module, providing additional control or information.

The unit is of single solid construction and is easily mounted with two screws. The TDC-100 is interchangeable with the AMC and LRC standard size controllers, and can be used to upgrade performance for those applications

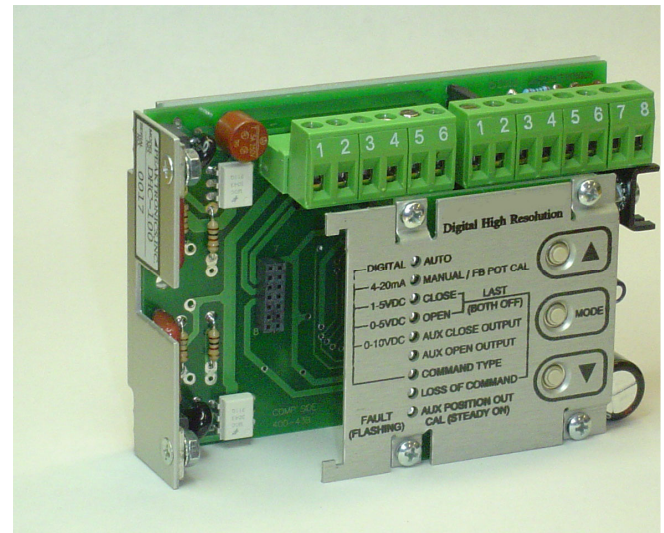

## FEATURES

- Positions to  $\pm 0.1^\circ$  with quarter-turn actuators ranging from 2 sec to 120 sec (with or without a brake).
- **Adaptive Control** feature continuously adjusts for load and actuator conditions and eliminates calibration procedures and auto-cal operations.
- Three button control provides easy setup and eliminates the need for instrumentation.
- **Polarity Detection** feature allows direct or reverse acting operation without re-wiring.
- **Electronic Brake** feature can eliminate need for a mechanical brake in many applications, and extends mechanical brake life when used.
- **Stall Detection** feature protects actuator motor from a stall condition.
- Automatic **Duty Cycle Control** feature prevents shutdown of a process due to a thermal overload of the actuator motor, and allows actuators rated for 25% duty or more to be safely used.
- Operating temperature range of 0 to 60°C

**OUTLINE**

117VAC	TDC-100	TDC-100C	(CE ready)
234VAC	TDC-100A	TDC-100D	☐☐
24VAC	TDC-100B	TDC-100E	(CE ready)

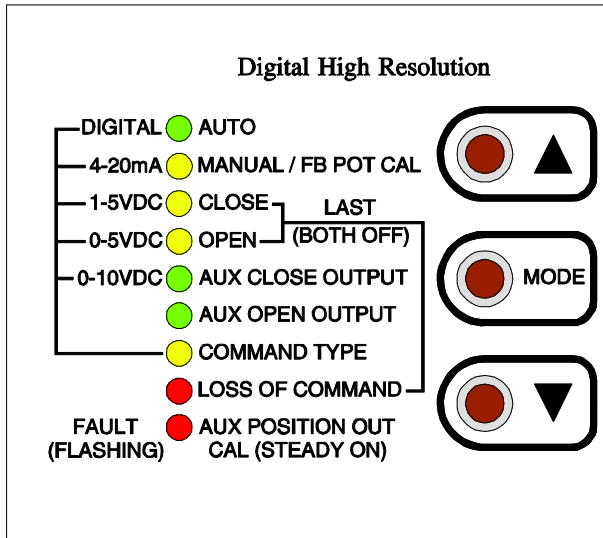

**FRONT PANEL**

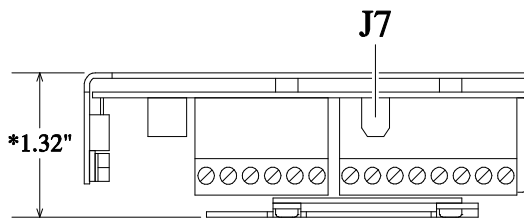

\* Add 0.04" when option module installed.

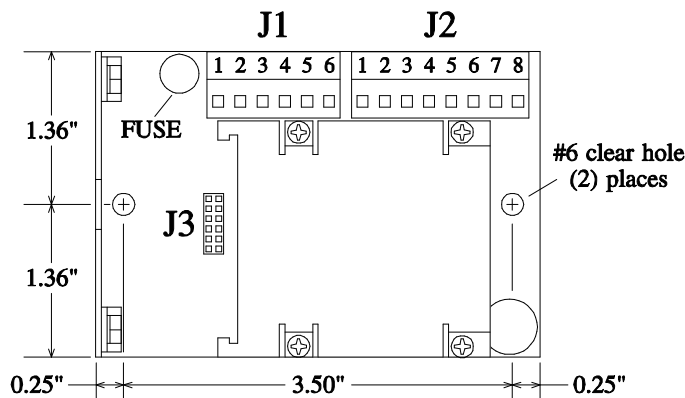

**ELECTRICAL CONNECTIONS**

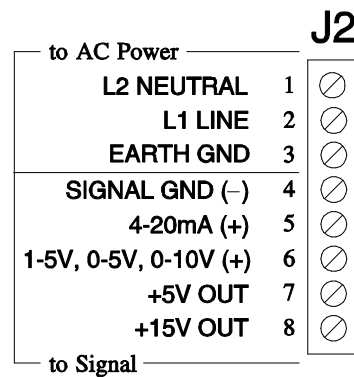
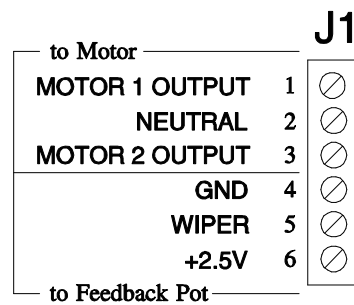

**J3**

**OPTION MODULE CONNECTOR**

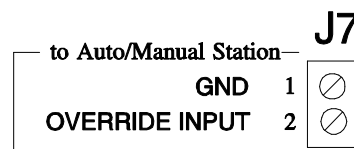

**BLOCK DIAGRAM**

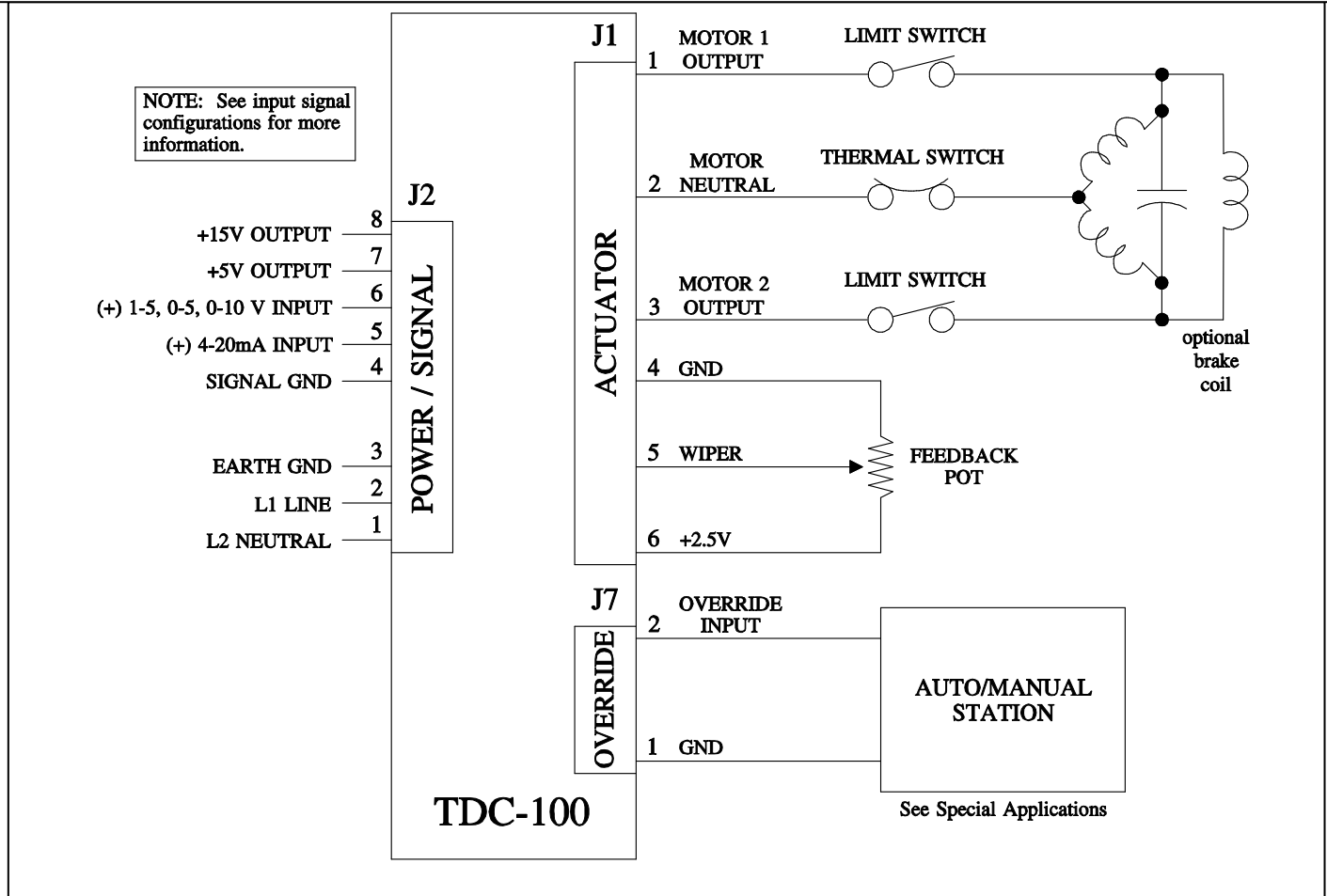

**DESCRIPTION**

The TDC-100 is rated for motors with up to 5A running currents and comes in three versions to accommodate different voltage applications. The TDC-100 and TDC-100C are rated for 117 VAC ±10%; the TDC-100A and TDC-100D are rated for 234 VAC ±10%, and the TDC-100B and TDC-100E are rated for 24 VAC ±10%. The unit is easily mounted with 2 screws and is equipped with removable screw terminals that provide for easy field wiring. The unit's size, mounting, and screw terminals are compatible with the AMC-100, AMC-101 and LRC-101 series controllers - the TDC-100 can be used as a direct replacement for those units in nearly any application. The simple three button control (MODE, ▲, and ▼) allows the user to

perform a complete set-up from the unit itself without the need for any instrumentation. The adaptive control feature of the TDC-100 eliminates the need for any calibration steps. In the simplest application, only the *closed* and *open* positions need to be set and the unit automatically and continuously sets all other parameters when placed in the AUTO mode.

**CAUTION !** These units are intended to be mounted in an appropriate enclosure to avoid electrical shocks and exposure to electrostatic charges. High voltages are present on the outside of the unit when power is applied. AC power should be disconnected and antistatic measures should be taken prior to any wiring of these units. A heater and thermostat should be used where condensation may occur.



Division of A-T Controls Inc.  
11363 Deerfield Road  
Cincinnati, Ohio 45242  
(513) 247-5465 Fax (513)247-5462

## INSTALLATION & MAINTENANCE MANUAL

### TDC Servo Card for WED / XED Series Actuators

#### POWER / SIGNAL (J2)

Power is connected to pins 1, 2, and 3 as shown in the block diagram. The fuse installed on the unit is rated for maximum output current that can be safely delivered by the AC outputs. Replacement fuses must not exceed the maximum rating to prevent damage to the unit. Smaller fuse sizes can be used with smaller motors - consult the actuator manufacturer for appropriate fuse size and type.

An appropriate command signal, either 0-5V, 0-10V, 1-5V, or 4-20mA, should be connected to pin 5 or 6 (as shown in the Block Diagram) while using pin 4 as the return *signal ground*. The TDC-100 must be configured for the type of command signal that is to be used (see COMMAND TYPE).

Pin 7 of J2 provides an auxiliary +5V output which can be used to connect a command potentiometer. By connecting one end of a potentiometer to pin 7, the other end to pin 4, and the wiper to pin 6, a local control knob can be implemented. Pin 8 provides an auxiliary +15VDC output which can be used to power an input or output 4-20mA transmitter.

#### ACTUATOR (J1)

The actuator motor and feedback potentiometer are connected to J1 as shown in the Block Diagram. The Motor Neutral wire must be connected to pin 2, while one motor winding is connected to pin 1 and the other winding to pin 3. The feedback potentiometer wiper must be connected to pin 5, while one end is connected to pin 4 and the other end to pin 6. The **Polarity Detection** feature of the TDC-100 automatically determines which motor winding to control based on where the *open* and *closed* positions are set; this feature also eliminates the need to rewire the unit for direct or reverse acting applications.

When the ▲ and ▼ buttons are used to control the actuator, the ▲ button will turn on the motor winding connected to pin 1, while the ▼ button will turn on the motor winding connected to pin 3. See MANUAL/FB POT CAL for more details.

#### OVERRIDE (J7)

J7 provides a simple 2-wire connection that can override the TDC-100 to perform a variety of

external control functions. Using an appropriate interface module, commonly used auto/manual station switches are easily implemented with low voltage/low current switches. See Special Applications for more details. The factory installed jumper between pins 1 and 2 enables normal operation of the TDC-100 and must be installed if the external override functions are not used.

#### MODE

The MODE button is used to select the desired function of operation. When the MODE button is pressed, the unit will switch to the next function and the appropriate LED indicator will turn on to let the user know which function is selected. Except for the MANUAL/FB POT CAL mode, the associated mode indicator will be steady on; for some of the modes other indicators will flash to indicate specific settings associated with the mode. Each of the modes are described in more detail in the following sections.

If a 0-5V or 0-10V command signal is used, the LOSS OF COMMAND function cannot be used. The MODE button will skip over the LOSS OF COMMAND mode when the unit is configured for a 0-5V or 0-10V command signal (see COMMAND TYPE). When the OVERRIDE mode is enabled (see OVERRIDE MODE), the MODE button is disabled and the Manual/Pot Cal indicator will turn on steady.

#### ADJUST UP (▲) and ADJUST DOWN (▼)

The adjust up (▲) and adjust down (▼) buttons are used to adjust the setting of any given function. When a function is selected by the MODE button, the adjust buttons will affect that function only. Note, that the AUTO mode does not have any adjustable settings, and therefore, the adjust up (▲) and adjust down (▼) buttons have no effect. Also, the adjust buttons are disabled in the OVERRIDE mode.



Division of A-T Controls Inc.  
 11363 Deerfield Road  
 Cincinnati, Ohio 45242  
 (513) 247-5465 Fax (513)247-5462

## INSTALLATION & MAINTENANCE MANUAL

### TDC Servo Card for WED / XED Series Actuators

#### OVERRIDE MODE

The OVERRIDE mode is not selected by the MODE button and can be enabled at anytime by connecting a resistance greater than 250 ohms to the Override Input (J7 pin 1 and pin 2). While the OVERRIDE mode is enabled, the MODE button and adjust buttons are disabled, and the Manual/Pot Cal indicator will turn on steady to indicate that the unit is being controlled by the Override Input. Shorting J7 pin 1 to pin 2 returns the unit to normal operation and the previously selected mode. Note that earlier models may not have connector J7, and therefore do not have the OVERRIDE mode feature.

Controlling the TDC-100 from the Override Input is accomplished by connecting a specific resistance to select a specific operation. The table below defines the operations and their associated resistance. See Special Applications for details on using the Override Input for an Auto/Manual Station.

RESISTANCE	OPERATION
> 4.3K ohms	OFF
3.3K ohms ±5%	LATCH
2K ohms ±5%	OPEN
1.2K ohms ±5%	CLOSE
510 ohms ±5%	STOP

The OPEN function will operate the motor in the *open* direction as set by the OPEN mode, while the CLOSE function operates the motor in the *closed* direction as set by the CLOSE mode. The LATCH function will maintain the previously selected function; this allows momentary switches to be used for the OPEN and CLOSE functions. The OFF and STOP functions turn the motor off, which also unlatches the OPEN or CLOSE functions.

Note that the OPEN and CLOSE functions may work in reverse until the *open* and *closed* positions are set by the OPEN and CLOSE modes. The TDC-100 will automatically turn the motor off

when the *open* or *closed* positions are reached. However, if a feedback fault occurs (see FAULT INDICATOR), the motor will be turned on for a period of 15 minutes in the selected direction. For this reason, limit switches should be used when using the OVERRIDE mode, and should be set to a position acceptable for the application. The 15 minute period can also be terminated using the OFF or STOP function.

The motor is also automatically turned off if the TDC-100 detects a stall (see STALL DETECTION). An OPEN or CLOSE operation can be attempted again after switching to the OFF, LATCH, or STOP functions first.

#### AUTO

The AUTO function is the normal mode of operation for the TDC-100; all the other functions are used to set up the unit. While in AUTO, the unit can be controlled by various external signals, some of which can be selected by the COMMAND INPUT function. When the unit is not in the AUTO mode, all external controls described below will be disabled.

Once the *open* and *closed* positions have been set, the AUTO mode will control the position of the actuator according to the command input signal. For an input signal of 0V (for 0-5V or 0-10V input), 1V (for 1-5V input), 4.0 mA (for 4-20mA input), or 0% (for a digital input), the TDC-100 will position the actuator to the *closed* position as set by the user. Conversely, an input of 10V, 5V, 20mA, or 100% will position the actuator to the defined *open* position.

When the TDC-100 is configured to use a 0-5V, 0-10V, 1-5V, or 4-20mA command, the command signal should be connected to the appropriate pin on J2 - note that the unused input pin must be left unconnected. When the TDC-100 is configured for a Digital command type, an appropriate communications option module must be installed. A communications module may be installed when using one of the analog command



Division of A-T Controls Inc.  
11363 Deerfield Road  
Cincinnati, Ohio 45242  
(513) 247-5465 Fax (513)247-5462

## INSTALLATION & MAINTENANCE MANUAL

### TDC Servo Card for WED / XED Series Actuators

types and can be used to override the analog command. The AUTO indicator will flash whenever the unit is being controlled by the communications module.

#### MANUAL/FB POT CAL

The MANUAL/FB POT CAL function allows manual operation of the actuator by using the adjust buttons (▲ and ▼) without affecting any other settings within the TDC-100. When the ▲ button is pressed, the motor winding connected to J1-1 is turned on while the ▼ button turns on the J1-3 winding. Whether the actuator moves toward the *open* or *closed* position depends on which motor winding is connected to J1-1 and J1-3.

The POT CAL feature provides an indication of the feedback potentiometer's setting. When the MANUAL/POT CAL function is selected, the Manual/Pot Cal indicator will turn on - it may flash or be on steady, depending on the actuator position. The indicator will be on steady whenever the TDC-100 detects that the feedback potentiometer is at midrange of its rotation. As the actuator moves, causing the feedback potentiometer to move away from midrange, the indicator will begin to flash, and the indicator will flash at a decreasingly slower rate as the actuator moves further away from midrange.

By using the adjust buttons to position the actuator to midstroke (half way point between the desired *open* and *closed* positions), the feedback potentiometer can then be adjusted until a steady light occurs. This insures that the feedback potentiometer has maximum range to reach the *open* and *closed* positions.

#### CLOSE

The CLOSE function is used to set the desired *closed* position; however, prior to doing this, the feedback potentiometer should be checked for optimum position (see MANUAL/POT CAL),

and the limit switches should be set outside of the operating range (see STALL DETECTION FEATURE). In the CLOSE function, the adjust buttons are used to set the actuator to any desired position, and upon pressing the MODE button (to select the next function, OPEN), the TDC-100 will retain the setting as the defined *closed* position.

Upon selecting the CLOSE function, the TDC-100 will begin moving the actuator to the previously set *closed* position; it is not necessary to make an adjustment if the unit has been previously set to the desired position. A command signal input of 0V, 1V, 4mA, or 0% automatically corresponds to the defined *closed* position.

#### OPEN

The OPEN function works the same way as the CLOSE function with the exception that the adjust buttons are used to set the desired *open* position. As with the CLOSE function, upon selecting the OPEN function, the actuator will move to the previously set *open* position. Once the desired position is set, the TDC-100 will automatically correspond a command signal input of 10V, 5V, 20mA, or 100% to the *open* position.

#### AUX CLOSE OUTPUT

The AUX CLOSE OUTPUT function is used to set an optional output setting that is associated with the *closed* position - an appropriate relay option module is required to use this output. The adjust buttons are used to set the actuator to a desired position. Whenever the actuator position falls between the defined *closed* position and the Aux Close position, the Aux Close Output indicator will flash. Additionally, the TDC-100 will turn on a relay output on the optional relay module - the output can be used to drive an alarm or merely act as an auxiliary limit switch.

Upon selecting the AUX CLOSE OUTPUT function, the TDC-100 will begin moving the



Division of A-T Controls Inc.  
11363 Deerfield Road  
Cincinnati, Ohio 45242  
(513) 247-5465 Fax (513)247-5462

## INSTALLATION & MAINTENANCE MANUAL

### TDC Servo Card for WED / XED Series Actuators

actuator to the previously set position. It is not necessary to make an adjustment if the unit has been previously set to the desired position.

#### AUX OPEN OUTPUT

The AUX OPEN OUTPUT function is used to set an optional output setting that is associated with the *open* position - an appropriate relay option module is required to use this output. The adjust buttons are used to set the actuator to a desired position. Whenever the actuator position falls between the defined *open* position and the Aux Open position, the Aux Open Output indicator will flash. Additionally, the TDC-100 will turn on a relay output on the optional relay module - the output can be used to drive an alarm or merely act as an auxiliary limit switch.

Upon selecting the AUX OPEN OUTPUT function, the TDC-100 will begin moving the actuator to the previously set position. It is not necessary to make an adjustment if the unit has been previously set to the desired position.

#### COMMAND TYPE

The COMMAND TYPE function is used to configure the command signal input for either 4-20mA, 1-5V, 0-5V, 0-10V, or digital so as to match the type of command signal being used. Upon selecting the COMMAND TYPE function, the Command Input indicator will turn on steady, while the indicator for the selected type will flash. Use the adjust buttons (▲ or ▼) to select the desired input type. The selection will be saved when the MODE button is pressed, which will also advance the unit to the LOSS OF COMMAND function.

#### LOSS OF COMMAND

When using 1-5V, 4-20mA, or a Digital input type for the command signal, the TDC-100 will detect when the command signal is lost or out

of range. A loss of command condition is detected whenever the input is disconnected, the input becomes less than 0.75V or 3mA, or the input becomes greater than 5.5V or 22mA. If the TDC-100 detects a loss of the command signal, the Fault indicator will flash and the actuator will be moved to one of three preset positions: the *open* position, the *closed* position, or the position last attained prior to losing the command signal. The LOSS OF COMMAND function is used to set the desired default position.

When the LOSS OF COMMAND function is selected, the adjust buttons are used to set the default position. The TDC-100 indicates the selected default setting by flashing the Open function indicator for the *open* default position, or it will flash the Close function indicator for the *closed* default position. When neither indicator is on, then the "last position" default is selected.

When a 0-5V or 0-10V command signal is used, a loss of command signal cannot be detected. Therefore, if the unit is configured for a 0-5V or 0-10V command signal (see COMMAND INPUT), the MODE button will not select the LOSS OF COMMAND function.

#### AUX POSITION OUT CAL

Note that the AUX POSITION OUT CAL indicator also serves as a Fault indicator. When the indicator is on steady, the AUX POSITION OUT CAL function is selected. When the indicator flashes, a Fault condition has been detected (see FAULT INDICATOR for details). The AUX POSITION OUT CAL function is used to calibrate an optional feedback transmitter output. An appropriate transmitter option module is required to use this feature.

When the AUX POSITION OUT CAL function is first selected (by pressing the MODE button while in the LOSS OF COMMAND function), the CLOSE indicator will flash, and the voltage or current associated with the *closed* position will appear at the option module output. If



Division of A-T Controls Inc.  
11363 Deerfield Road  
Cincinnati, Ohio 45242  
(513) 247-5465 Fax (513)247-5462

## INSTALLATION & MAINTENANCE MANUAL

### TDC Servo Card for WED / XED Series Actuators

desired, the output can be adjusted (using the adjust buttons) to any value from 0 to 10V (for a voltage output) or 0 to 20mA (for a current output). The new setting is then associated with the *closed* position.

Pressing the MODE button again will leave the unit in the AUX POSITION OUT CAL function except that the OPEN indicator will flash, and the output voltage or current associated with the *open* position will appear at the option module output. Like the *closed* setting, the output can be adjusted to any voltage (from 0 to 10V) or current (from 0 to 20mA), and the new setting is then associated with the *open* position.

### FAULT INDICATOR

The TDC-100 detects various fault conditions that prohibit the unit from controlling the actuator. When any of these conditions are detected, the Fault indicator will flash, and the motor outputs are turned off until all fault conditions have been corrected. If an appropriate relay option module is installed, the Fault relay output on the option module will also turn off. A communications option module can read the specific condition(s) causing the fault. Note that a fault condition DOES NOT disable the motor outputs when manually controlling the actuator with the the adjust buttons; while useful for troubleshooting, care should be exercised when operating the motor under a fault condition. The OVERRIDE mode can also operate the motor when a fault condition exists - see OVERRIDE MODE for details. The various fault conditions are described below:

**LOSS OF COMMAND** - If the command signal is disconnected or out of range, the fault indicator will remain on until the signal is reconnected or back in range.

**FEEDBACK POT FAULT** - A fault condition is detected whenever the feedback signal is out of

range (that is, less than 5% of the potentiometer value or more than 95% of the potentiometer value), or when any of the potentiometer connections are broken. Normal operation resumes when the potentiometer is reconnected or back in range.

**MOTOR 1 STALL** - A fault condition is detected when no actuator motion is detected while the Motor 1 output is turned on. The fault condition will disable the Motor 1 output only, and the fault is cleared when the TDC-100 detects a motion greater than 1.5° in either direction. The fault can be cleared if 1) the command signal commands a Motor 2 operation, 2) manual operation with the adjust buttons results in a motion greater than 1.5°, or 3) a mechanical manual override forces the 1.5° motion, provided the mechanical motion is monitored by the feedback pot.

**MOTOR 2 STALL** - A fault is detected when no actuator motion is detected while the Motor 2 output is turned on. The fault can be cleared in the same manner as a Motor 1 Stall (see above).

**DOUBLE STALL** - If the TDC-100 detects no actuator motion in either direction, both motor outputs will be disabled. The command signal cannot clear this condition; only manual operation or a mechanical override can clear the fault. Alternatively, the TDC-100 can be powered off and then on to temporarily clear the fault; however, this practice should be avoided without permanently correcting the cause of such a fault.

### STALL DETECTION FEATURE

The **Stall Detection** feature of the TDC-100 (see FAULT INDICATOR) essentially performs a similar function as commonly used torque switches; however, the differences should be considered before eliminating the torque switches. The TDC-100 feature does not measure torque, but rather motion; if the load is sensitive to excessive torque, the torque switches may be desirable. Since





Division of A-T Controls Inc.  
11363 Deerfield Road  
Cincinnati, Ohio 45242  
(513) 247-5465 Fax (513)247-5462

## INSTALLATION & MAINTENANCE MANUAL

### TDC Servo Card for WED / XED Series Actuators

common torque switches are mechanical devices, they can provide a fail safe feature in the event of electrical failures (such as shorted wires or damage to the TDC-100).

The **Stall Detection** feature is useful for detecting when any of the motor wires become disconnected. However, limit switches employed in actuators essentially disconnect one of the motor windings. The TDC-100 will detect this as a motor stall. To avoid this condition, the limit switches must be set outside of the operating range set by the CLOSE and OPEN functions.

#### ELECTRONIC BRAKE FEATURE

The **Electronic Brake** feature of the TDC-100 provides highly reliable and accurate braking of the motor, and it is a key element in achieving high resolution. A mechanical brake can still be implemented without interfering with the TDC-100 operation. Mechanical brakes can be useful for providing a holding brake in the event power to the actuator is lost.

Since the **Electronic Brake** feature provides the primary braking of the motor, the life of a mechanical brake is dramatically extended. Additionally, the **Adaptive Control** feature of the TDC-100 automatically compensates for changes in a mechanical brake's performance due to temperature or age.

Note that the actuator's limit switches should be set outside of the operating range set by the CLOSE and OPEN functions. The **Electronic Brake** feature degrades in performance if a limit switch is engaged. Limit switches exhibit wide variations, and the TDC-100 can position the actuator more precisely at *closed* and *open* than the limit switches. A limit switch serves better as a fail safe device to protect against electrical failures in the actuator.

#### DUTY CYCLE CONTROL FEATURE

The **Duty Cycle Control** feature of the TDC-100 allows actuators rated at 25% duty or more to be safely used in automated valve applications. The TDC-100 accurately monitors the relative heating of the motor and automatically duty cycles the unit at a safe level when a process becomes unstable, or if a control loop is not properly set. While the thermal switch in the motor protects the motor from overheating, thermal switches can shutdown the actuator for ten minutes or more. Further, typical thermal switches do not activate until temperatures inside the actuator become too high for other components in the actuator.

The **Duty Cycle Control** feature allows continuous operation of the motor until it detects an excess heat buildup in the motor (usually well below the limit of the thermal switch). At that time, duty cycle operation is automatically enabled and continues until the motor cools enough to resume continuous operation. The duty cycle period is approximately 2 seconds with an on time that automatically varies depending on the heating of the motor. While this operation slows down the actuator's operation, it does not impact the resolution performance of the TDC-100, and it prevents disruption of a process due to a thermal switch shutdown.

## OPTION MODULES

Various option modules can be plugged into the TDC-100 option module connector, J3. Option modules provide additional features such as position feedback signals, auxiliary switch outputs, or digital

communications. Contact the factory for the latest available modules. Refer to the diagram below for instructions on installing an option module.

Plug option module into J3, lock module in front panel slots, and retighten front panel screws.

Loosen front panel screws and lift front panel up to allow option module to plug in underneath.

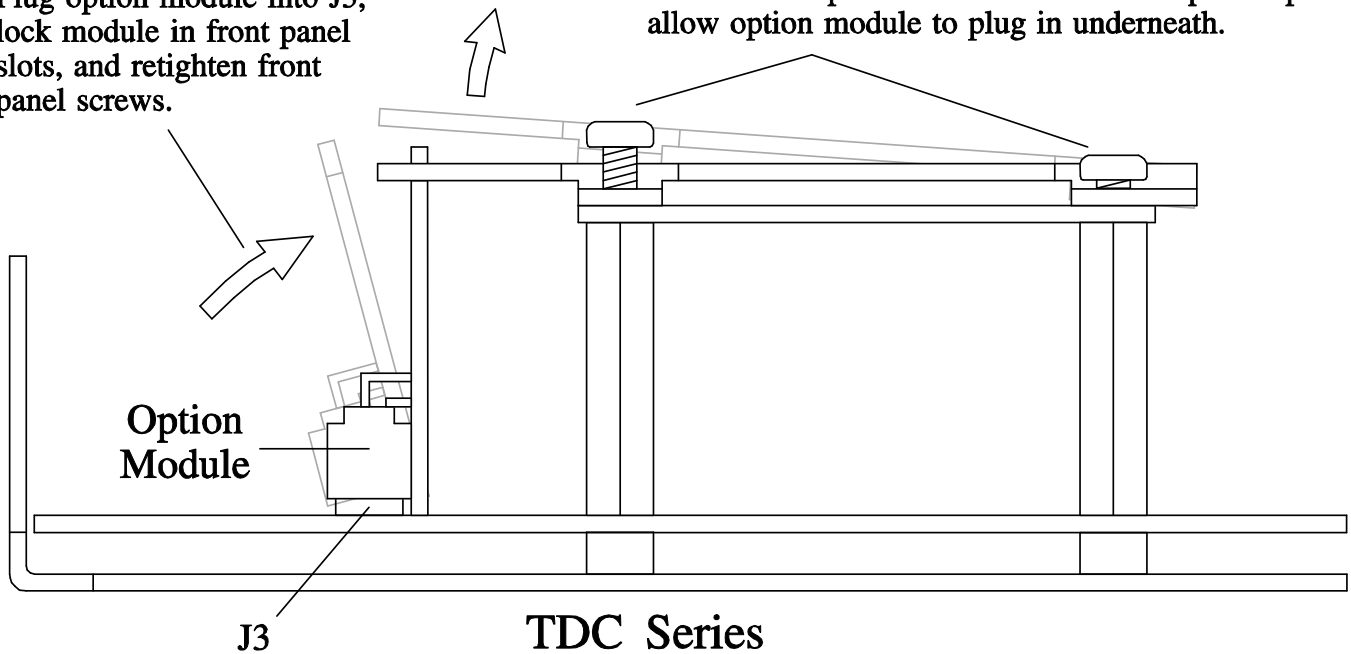

**TDC Series**  
**Installing an Option Module**



Division of A-T Controls Inc.  
11363 Deerfield Road  
Cincinnati, Ohio 45242  
(513) 247-5465 Fax (513)247-5462

## INSTALLATION & MAINTENANCE MANUAL

TDC Servo Card for  
WED / XED Series Actuators

### SPECIFICATIONS

#### POWER REQUIREMENTS

TDC-100, TDC-100C: 117VAC  $\pm 10\%$ , 50/60 Hz  
TDC-100A, TDC-100D: 234VAC  $\pm 10\%$ , 50/60 Hz  
TDC-100B, TDC-100E: 24VAC  $\pm 10\%$ , 50/60 Hz  
12 VA typical (not including output load)  
Fuse Type: 5A TR5 Slo-Blo (replaceable)

#### COMMAND SIGNAL INPUT

Input Impedance  
20K ohms (1-5 VDC, 0-5 VDC, 0-10 VDC Input)  
251 ohms  $\pm 1\%$  (4-20 mA Input)  
Loss of Command threshold  
< 0.75V or > 5.5V (1-5 VDC input)  
< 3mA or > 22mA (4-20mA input)

#### FEEDBACK SIGNAL INPUT

Input Voltage: 0 to 2.5 VDC  
External Feedback Potentiometer: 1K ohm

#### POWER SUPPLY OUTPUTS

+15V OUT (J2-8): 125mA maximum (not including option module)  
+5V OUT (J2-7): 5mA maximum  
**NOTE:** Do not connect these outputs to other power supplies.

#### AC MOTOR OUTPUTS

Off-state Leakage Current: <15mA  
Maximum Load Current @ 60°C: 5A

#### ENVIRONMENTAL

Operating Temperature Range: 0 °C to 60 °C  
Storage Temperature Range: -40 °C to 85 °C  
Relative Humidity Range: 0 to 90 % (noncondensing)

#### CE CERTIFICATION (DHC-100D only)

EN55011, Class A RF Emission  
EN61000-4-2 Electrostatic Discharge (ESD)  
EN61000-4-3 Radiated RF Immunity (10V/m)\*  
EN61000-4-4 Electrical Fast Transient (EFT)  
EN61000-4-5 Surge Pulse (Class 3 with less than 10m cable)  
EN61000-4-6 Conducted RF Immunity (3V)  
EN61000-4-11 Brown Out / Black Out  
Peaktronics reference document: 1001-6A

\* The unit exhibits a particular sensitivity at 137MHz. Installations suspected of having a strong exposure near the specified limit in the range of 132Mhz to 142Mhz can increase immunity by installing a clamp-on ferrite (250 ohms or more at 100MHz) around the I/O cable(s). A Steward 28A2029-0A2 ferrite or equivalent is recommended.

**WIRING DIAGRAMS**  
Input Signal Configurations

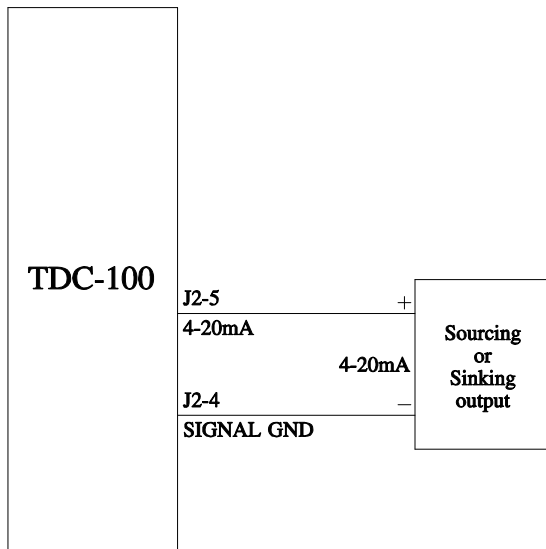

4-20mA Input using a self powered transmitter

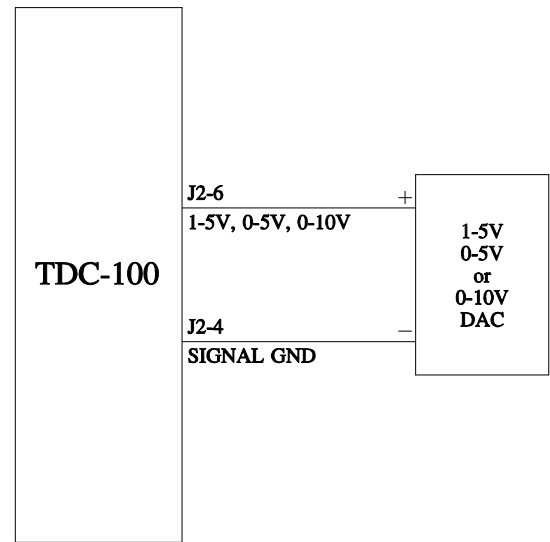

1-5/0-5/0-10V Input using digital-to-analog card

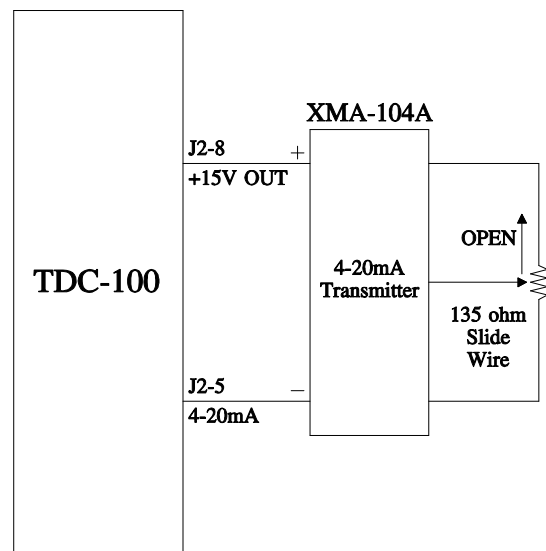

135 ohm Slide Wire  
using the 4-20mA Input Signal

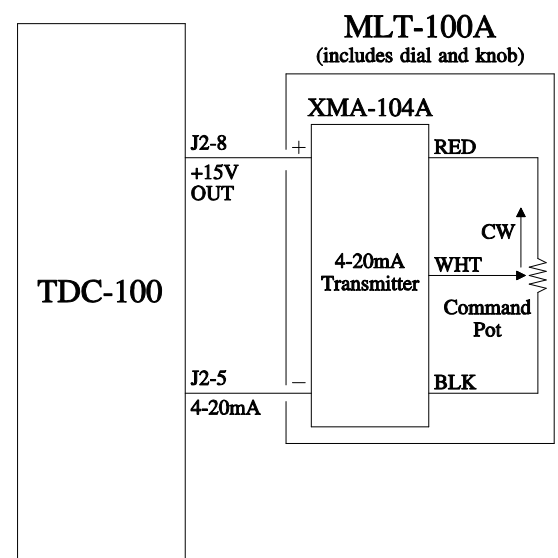

Remote Command Pot  
using the 4-20mA Input Signal

**WIRING DIAGRAMS**

Special Applications

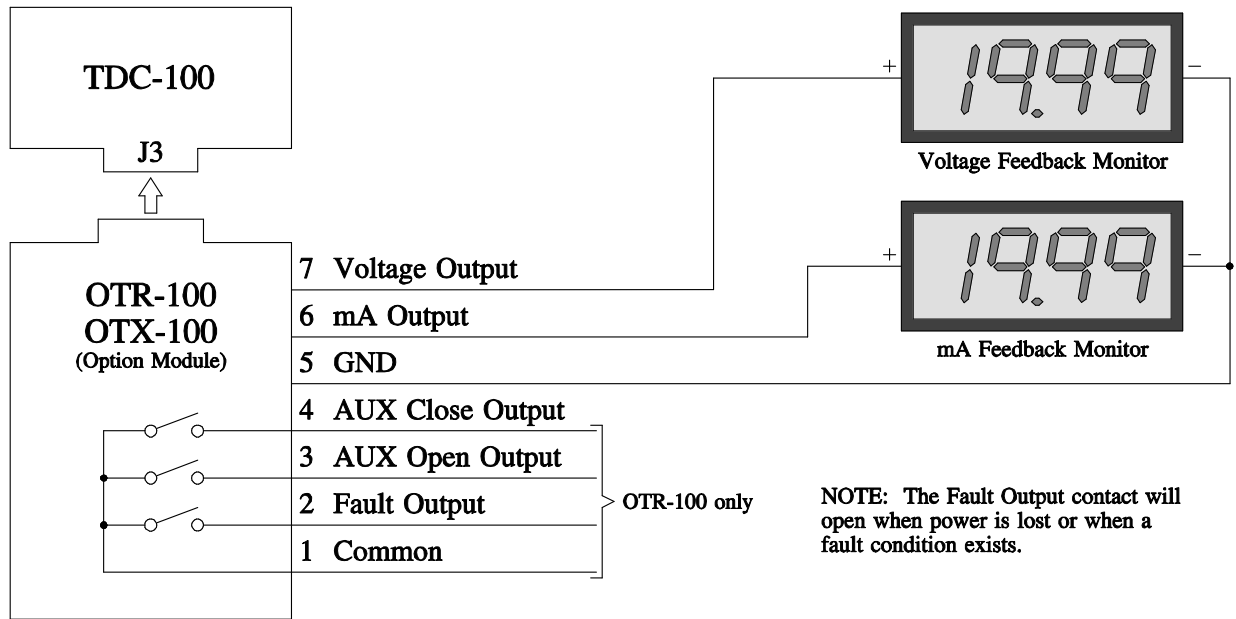

Connecting a position feedback transmitter

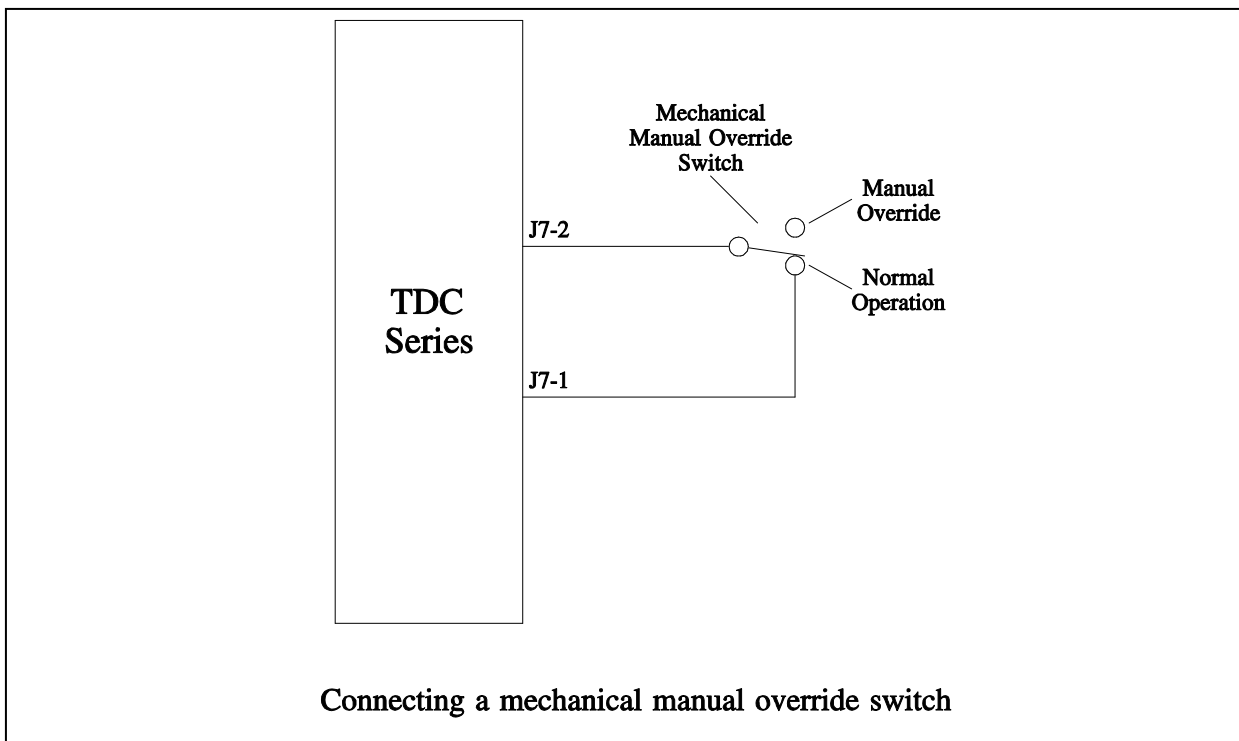

Connecting a mechanical manual override switch

**WIRING DIAGRAMS**

Special Applications (continued)

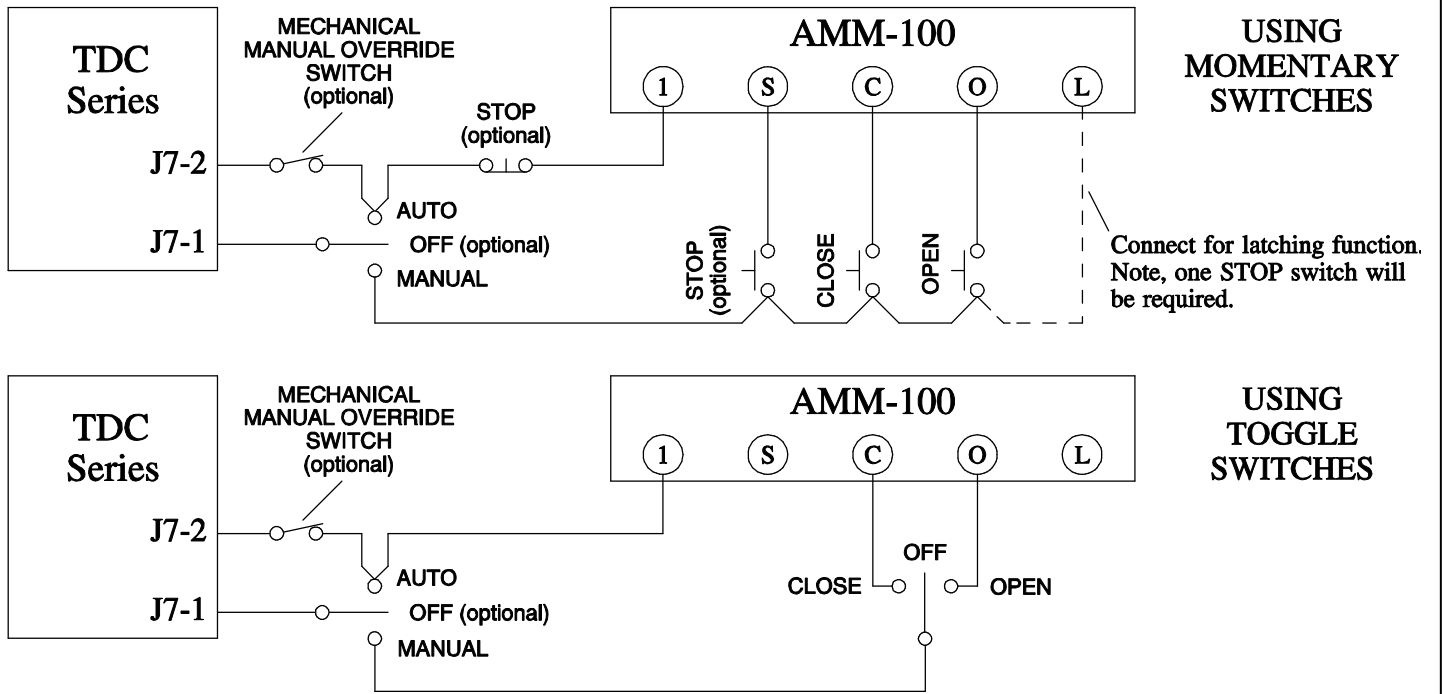

Connecting an auto/manual station