

SY-SERIES S04DA75 THRU S06DA180 & S04SR75 THRU S06SR180 DOUBLE ACTING & SPRING RETURN SCOTCH YOKE ACTUATORS

INTRODUCTION

A-T Controls SY scotch yoke actuators have been designed and engineered to provide high cycle-life to meet the demands of our customers. The actuators are equipped with dual travel stops and accessory mounting.

!!!WARNING!!!

FOR YOUR SAFETY, IT IS IMPORTANT THAT BEFORE REMOVING ANY COMPONENTS OF THE ACTUATOR, ENSURE THAT ALL PNEUMATIC AND ELECTRICAL SUPPLIES ARE DISCONNECTED AND LOCKOUT AND TAGOUT PROCEDURES ARE IMPLEMENTED. PLEASE CONSULT FACTORY IF YOU HAVE ANY QUESTIONS ON ANY OF THE PROCEDURES LISTED BELOW.

TABLE OF CONTENTS	
SECTION	DESCRIPTION
1	INSTALLATION OF ACTUATOR
2	AIR SUPPLY
3	LUBRICATION
4	STORAGE OF ACTUATORS/ INFREQUENTLY CYCLED
5	DOUBLE ACTING OPERATION
6	SPRING RETURN OPERATION
7	TRAVEL ADJUSTMENT
8	REPLACEMENT OF CYLINDER SEALS
9	CONVERTING FROM DOUBLE ACTING TO SPRING RETURN
10	CONVERTING FROM FAIL CLOSED TO FAIL OPEN
11	SEAL KIT AND REPAIR PARTS
12	BILL OF MATERIALS

1. Installation of Actuator

Triac actuators are adapted to the valve by means of an intermediate bracket and coupler. The coupler adapts the output of the actuator to the valve shaft. Standard mounting kits provide for mounting the actuator in the direction of the pipe. If different orientations are required please consult the factory when the order is placed.

Before mounting the actuator on the valve insure that both units are in the proper orientation, i.e. both units open or closed. Make sure the coupler fits into the actuator and onto the valve before assembly. Also check the bracket for proper fit. After mounting the actuator, it may be necessary to adjust the travel stops for proper open and closed valve position. Always consult the manufactures installation manual for

specific details before proceeding. Pneumatically stroke the actuator several times to assure smooth proper operation.

2. Air Supply

Pneumatic piping to the actuator and associated accessories should follow the best practices for instrument pneumatic piping systems, I.E. lines free of water, oil, pipe sealant or other contaminants. The operating medium is to be filtered dry air or inert gas which is filtered to 50 micron particles size or less. It is extremely important that the actuator be powered with the proper air pressure and air volume. Maximum working pressure is 100 PSI. Consult the SY series catalog for a complete listing of MOP (maximum operating pressure) and MAWP (Maximum Allowable Working Pressure) Spring return actuators are vented to the atmosphere through the end cap. The Pressure Cylinder must be purged if a corrosive atmosphere exists. Please contact Triac Controls for possible solutions if this condition exists.

3. Lubrication

Triac actuators are factory lubricated for life and additional lubrication is not normally required. However, for actuators performing 100,000 cycles or more, an oil mist lubricator is recommended. Oil mist lubrication requires a mineral oil type ISO VG32 Class 1 for usage in temperature range 15 to 158 Deg. F. Oil mist lubricator must be set to the lowest setting. Once begun, the oil mist lubrication cannot be discontinued.

CAUTION

If the actuator is equipped with a pneumatic positioner or pneumatic controller, oil mist lubricated air cannot be used unless the instrument manufacturer indicates that the instrument is compatible with lubricated air.

4. Actuators in Storage or infrequently cycled.

Actuators in storage should be kept dry and protected from adverse conditions until installed. Original port protectors must be kept in the ports during storage. Actuators must be cycled every 90 days in storage or in operation. Actuators that do not cycle in 90 days should have a provision to jog the actuator to check for operation if a full cycle cannot be achieved.

5. Double Acting Operation

Applying air pressure to the CCW Port drives the piston toward the end cap which turns the yoke counterclockwise when viewed from the accessory side of the actuator. When pressure is applied to the CW Port the piston is driven towards the adapter which turns the yoke clockwise. This is shown in Figure 1

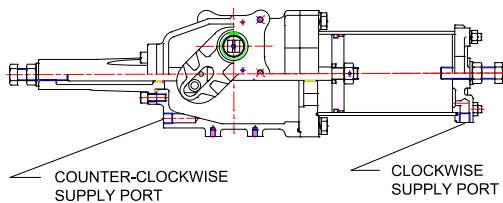

Figure 1

6. Spring Return Operation

Applying air pressure to the CCW Port drives the piston toward the end cap as the spring is compressed. This rotates the yoke counterclockwise when viewed from the accessory side of the actuator. When pressure is relieved at the CCW Port the spring drives the piston towards the adapter which turns the yoke clockwise. This is shown in figure 2. To reverse the failure mode turn the actuator over.

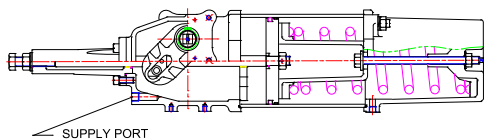

Figure 2

7. Travel Adjustment

The Triac SY actuators have + or - 8 degree adjustment of the end of travel stops in both the open and close directions.

CAUTION: DO NOT ATTEMPT TO ADJUST STOP BOLT WITH AIR PRESSURE OR SPRING FORCE APPLIED TO THE STOP BOLT. ALWAYS JOG ACTUATOR AWAY FROM STOP BOLT BEFORE ADJUSTING.

The stop bolts are in the rod cover and the end cap of the actuator. Figure 3 shows the stop bolt locations. Loosen the lock nut and adjust stop bolt as required then retighten lock nut.

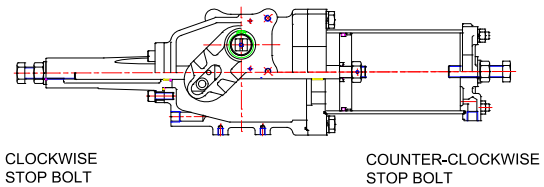

Figure 3

!!!WARNING!!!

FOR YOUR SAFETY, IT IS IMPORTANT THAT BEFORE REMOVING ANY COMPONENTS OF THE ACTUATOR, ENSURE THAT ALL PNEUMATIC AND ELECTRICAL SUPPLIES ARE DISCONNECTED AND LOCKOUT AND TAGOUT PROCEDURES ARE IMPLEMENTED.

8. Replacement of Cylinder Seals

When the cylinder seals must be replaced, because of leakage or a preventive scheduled maintenance, the following procedure must be followed. Note only the soft parts indicated on page 5 are included in a seal kit. If additional parts are required they must be ordered separately.

1. Disconnect electrical supplies and shut off pneumatic supply, vent actuator and remove from valve or damper.
2. Remove any accessories mounted on top of actuator.
3. For spring return actuators the spring tension must be relieved before starting. Apply air pressure until the piston moves off the stop bolt located on the rod cover. **DO NOT LOOSEN THE BOLT ON THE END CAP BY THE SPRING CYLINDER.** Loosen the hex nut (item 47) then back out the stop bolt (item 48) until the preload is relieved. For double acting units the actuator should be in the clockwise position with the piston next to the center body front flange (item 37).
4. Vent all air pressure from the cylinder (item 14).
5. Remove the 4 nuts (item 24) on the spring cartridge tie rods (item 2). Then slide the spring cartridge out over the tie rods.
6. Remove the tie rods (item 2).
7. Remove the cylinder (item 21) from the front flange (item 37) by pulling over the piston (item 7). Use caution not to scratch the cylinder bore when sliding over piston.

8. Remove the lock nut setscrews (item 19) from the lock nut (item 20). Remove the lock nut (item 20).
9. Remove the piston (item 7), piston O-ring (item 34).
10. Remove front flange bolt (item 35) and lock washer (item 36). Remove front flange (item 37) carefully over piston rod.
11. Remove the bolts (item 11) from rod cover and carefully slide over the piston rod.
12. Remove snap ring (item 11) on yoke shaft (item 39) and remove yoke shaft spacer (item 17). Slide yoke shaft (item 39) down thru body and carefully remove from bottom of actuator as not to damage the upper and lower bearings and O-rings.
13. Remove the piston rod and yoke assembly thru the pressure port opening.
14. Remove the O-rings from the piston and both flanges.
15. Clean all parts with a mild solvent that will not attack the coating on the parts.
16. The center body assembly should be inspected before the pressure group is rebuilt.
17. Inspect the Yoke pin bushing (bronze slider) (item 4) for wear along with the slot in the yoke arm.
18. Inspect the upper and lower yoke shaft bearings (item 14) for wear.
19. Wipe out old grease and replace with new grease on all sliding surfaces.
20. Install new O-rings to replace the old O-rings removed earlier.
21. Install the piston rod and yoke assembly thru the pressure port opening.
22. Then reinstall Yoke shaft into yoke aligning the key into the keyway, then install bearings using care not to harm the bearings or the O-rings. Reinstall the yoke washer and snap ring.
23. Install front flange O-ring in groove.
24. Reinstall front flange with rod bearing over piston rod and slide into position and torque bolts in a diagonal pattern.
25. Install rod cover O-ring on rod cover.
26. Reinstall rod cover and rod bearing over piston rod and slide into position and torque bolts in a diagonal pattern.
27. Check actuator for freedom of movement before installing pressure group.
28. Lightly grease the O-ring for the front flange and install in the groove.
29. Lightly grease O-ring (item 34) and slide over piston rod. Slide piston over piston rod and install lock nut Tighten securely and install set screws.
30. At this point the piston should be able to be pushed back and forth to insure that all parts are in proper alignment and working properly.
31. Lightly grease piston grooves and install O-ring and back-up strip.
32. Lightly grease cylinder completely on the inside surface and carefully slide over the piston until seated on the adapter.
33. Lightly grease the O-ring for the end cap and install in the groove. Place end cap over the tie rods and seat on the cylinder. Be sure to keep the original alignment of the NPT port.
34. Reinstall the tie rod nuts and tighten in a diagonal pattern.
35. To pressure test a double acting actuator proceed to the next step for a spring return go the step 39.
36. Connect 2 psig air to the body (CCW Port) and cycle the actuator then connect to the end cap (CW Port) and cycle the actuator several times.
37. Apply 100 psig air to the Body and check for leakage at the adapter/cylinder connection and the yoke bearings. Place a flexible tube in the end cap NPT port and check for leakage across the piston by checking for bubbles in a cup of water. Relieve air pressure on cylinder.
38. Apply 100 psig air to the end cap and check for leakage at the end cap/cylinder connection. Place a flexible tube in the body NPT port and check for leakage across the piston. Relieve air pressure on cylinder.
39. Apply supply pressure to the body and check for leakage at the front flange/cylinder connection and the yoke bearings. Then check for leakage across the piston by using the method in step 37 above.
40. Position stop bolts back to 90 degrees position and tighten lock nuts.
41. The actuator is now ready to return to service.

9. Converting from Double Acting to Spring Return

!!!WARNING!!!

FOR YOUR SAFETY, IT IS IMPORTANT THAT BEFORE REMOVING ANY COMPONENTS OF THE ACTUATOR, ENSURE THAT ALL PNEUMATIC AND ELECTRICAL SUPPLIES ARE DISCONNECTED AND LOCKOUT AND TAGOUT PROCEDURES ARE IMPLEMENTED.

1. Disconnect electrical supplies and shut off pneumatic supply, vent actuator and remove from valve or damper.
2. Loosen the stop bolt nut on rod cover and back out.
3. Remove the Tie rod nuts (item 24) and the lock washers (item 23). Remove the end cap and inspect the O-ring.
4. Install Spring cartridge end cap and replace lock washers and nuts.
5. Apply air pressure to compress spring and loosen nut on spring end cap to adjust travel stop as needed for the open position.
6. Apply air pressure and check for smooth operation.

10. Changing from “Spring Closed” to “Spring Open”

To convert from spring closed to spring open requires that the actuator be mounted with the Triac logo towards the valve. Simply turn the actuator over. As both sides are symmetrical.

11. Seal kits and Repair Parts

To order replacement seal kits or spare parts please provide the following information:

Actuator Model Number
Serial Number
Type of seal kit (Nitrile standard, low temperature, Viton)
Item Number, Description and quantity for repair parts.

Bill of Materials

NO.	QTY.	SEAL KIT	DESCRIPTION	MATERIAL
1	1		YOKE KEY	ANSI 1045
2	4		TIE ROD	ANSI 1045
3	1		YOKE	A536 GR. 65-45-12
4	2		YOKE BEARING	B505 C836
5	2		YOKE PIN RETAINING RING	STEEL
6	2		DRIVE BLOCK PIN	STEEL
7	1		PISTON	ASTM A36
8	1	*	PISTON O-RING	NBR
9	1		PISTON WEAR BAND	PTFE
10	1	*	STOP BOLT O-RING	NBR
11	4		ROD COVER BOLT	A193 GR. B7
12	1		DRIVE BLOCK	ANSI 1045
13	2	*	SHAFT BUSHING O-RING	NBR
14	2		YOKE SHAFT BEARING	B505 C836
15	2		YOKE SHAFT RETAINING RING	STEEL
16	2	*	YOKE SHAFT O-RING	NBR
17	2		YOKE SHAFT WASHER	A193 GR. B7
18	2		ROD BEARING	DU BEARING
19	2		LOCK NUT SETSCREW	A193 GR. B7
20	1		LOCK NUT	A194 GR. 8
21	1		CYLINDER	A106 GR. A CHROME PLATED
22	1		STOP BOLT WASHER	A193 GR. B7
23	4		TIE ROD LOCKWASHER	A193 GR. B7
24	4		TIE ROD NUT	A193 GR. B7
25	1		SPRING	SAE 9254
26	1		TRAVEL STOP BOLT WASHER	A193 GR. B7
27	1		TRAVEL STOP BOLT	A193 GR. B7
28	1		TRAVEL STOP BOLT NUT	A193 GR. B7
29	1	*	STOP BOLT O-RING	NBR
30	1		SPRING GUIDE BUSHING	NYLON 6
31	1		CYLINDER COVER	A536 GR. 65-45-12
32	2	*	CYLINDER O-RING	NBR
33	1		SPRING RETAINER	A536 GR. 65-45-12
34	1	*	PISTON ROD O-RING	NBR
35	4		FRONT FLANGE BOLT	A193 GR. B7
36	4		FRONT FLANGE LOCKWASHER	A193 GR. B7
37	1		FRONT FLANGE	A536 GR. 65-45-12
38	1	*	FRONT FLANGE O-RING	NBR
39	1		YOKE SHAFT	17-4 PH STAINLESS STEEL
40	1		HOUSING	A536 GR. 65-45-12
41	1		YOKE PIN	17-4 PH STAINLESS STEEL
42	4		ROD BEARING RETAINING SCREW	A193 GR. B7
43	1	*	PISTON ROD COVER O-RING	NBR
44	1		PISTON ROD	ANSI 4140 CHROME PLATED
45	1		ROD COVER	A536 GR. 65-45-12
46	1		TRAVEL STOP WASHER	A193 GR. B7
47	1		TRAVEL STOP NUT	A193 GR. B7
48	1		TRAVEL STOP BOLT	A193 GR. B7

Spring Return and Double Acting Figures on pg 6.

* Component of Repair Kit

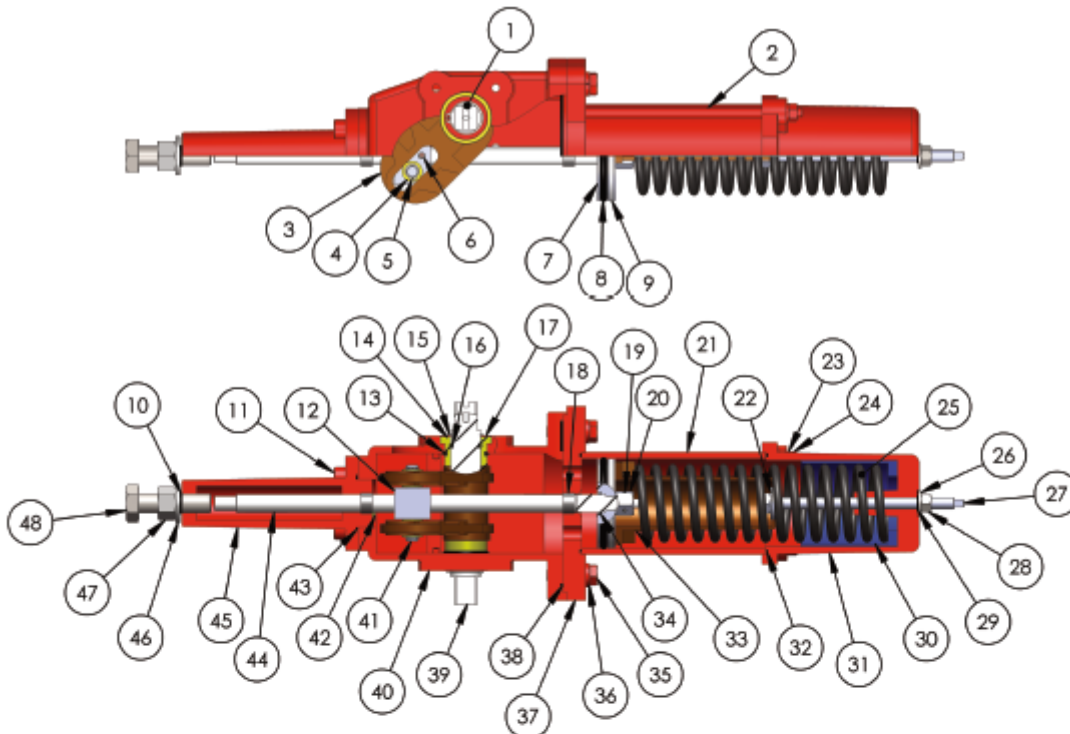

SPRING RETURN ACTUATOR

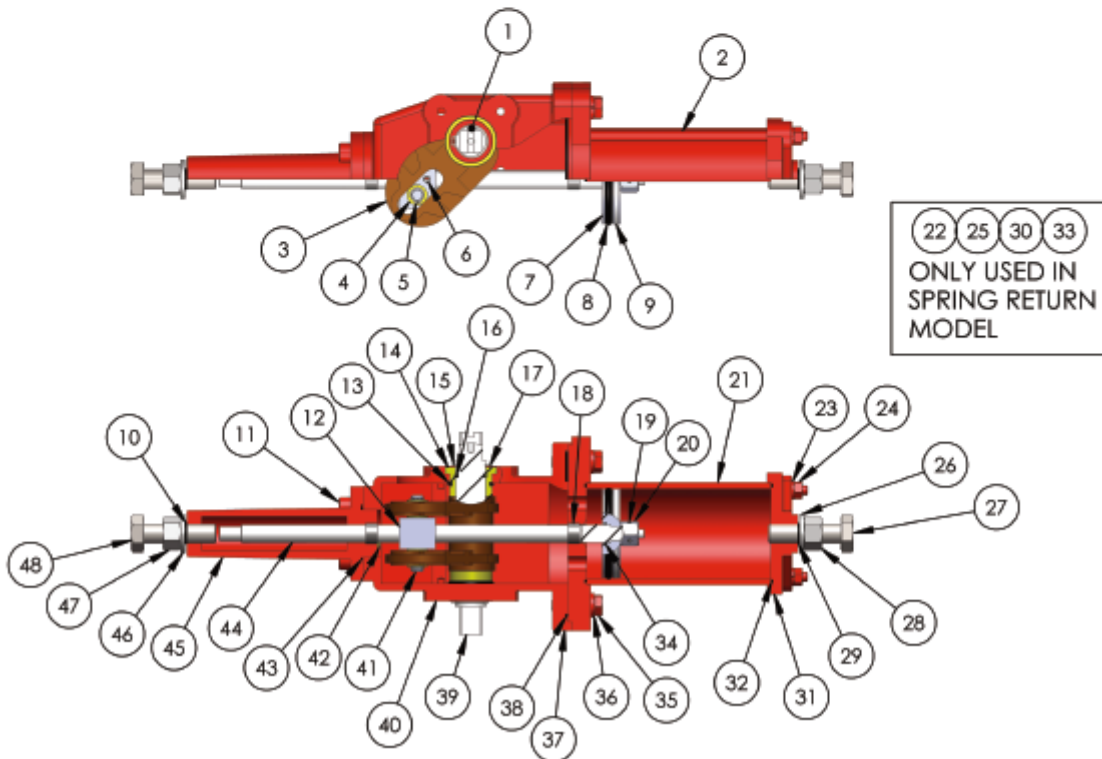

DOUBLE ACTING ACTUATOR

A-T Controls product, when properly selected, is designed to perform its intended function safely during its useful life. However, the purchaser or user of A-T Controls products should be aware that A-T Controls products might be used in numerous applications under a wide variety of industrial service conditions. Although A-T Controls can provide general guidelines, it cannot provide specific data and warnings for all possible applications. The purchaser / user must therefore assume the ultimate responsibility for the proper sizing and selection, installation, operation, and maintenance of A-T Controls products. The user should read and understand the installation operation maintenance (IOM) instructions included with the product, and train its employees and contractors in the safe use of A-T Controls products in connection with the specific application.

While the information and specifications contained in this literature are believed to be accurate, they are supplied for informative purposes only. Because A-T Controls is continually improving and upgrading its product design, the specifications, dimensions and information contained in this literature are subject to change without notice. Should any question arise concerning these specifications, the purchaser/user should contact A-T Controls.

For product specifications go to <http://download.a-tcontrols.com/>

A-T Controls, Inc. • 9955 International Boulevard, Cincinnati, OH 45246 • Phone: (513) 530-5175 • Fax: (513) 247-5462 • www.atcontrols.com