

Contents: Series 20/21C IOM

| | |
|-----------------------------------|---|
| SCOPE | 2 |
| INSTALLATION | 2 |
| VALVE OPERATION | 2 |
| DISASSEMBLY OF VALVE | 2 |
| RE-ASSEMBLY OF VALVE | 2 |
| Table A: Gland Nut Torque | 3 |
| Series 20 Bill of Materials | 3 |
| Series 21 Bill of Materials | 4 |

SCOPE

CAUTION

- For your safety, read this manual before installation or service. All persons involved in the installation/removal and disassembly/reassembly of the valve should wear the proper personal protective equipment.
- Before installing or servicing, please ensure the line pressure has been relieved and any hazardous fluids have been drained or purged from the system.
- Ensure that all Lockout and Tagout procedures for the system have been properly implemented.

USE

- Maximum results and long life of valves can be maintained under normal working conditions and according with pressure/temperature ratings and corrosion data chart.

INSTALLATION

GENERAL INFORMATION FOR INSTALLATION

- The valve can be installed in any position on the pipeline.
- Before installation of the valve, the pipe must be flushed clean of dirt, burrs, and welding residue or the seats and ball surface will be damaged. The pipe must be free from tension and in proper alignment. Check to ensure that all connections are free from defects.
- Use conventional sealant, such as hemp core, Teflon, etc. on the threads. Apply wrench only on the hexagon of the valve ends. Tightening by using the valve body or lever can seriously damage the valve. In some applications, screwed valves are back welded on site. These valves must be treated as per instructions for weld end valves before back welding.

VALVE OPERATION

- To OPEN the valve: turn the handle counterclockwise until the handle is parallel with the pipeline and the handle has contacted the handle stop.
- To CLOSE the valve: turn the handle clockwise until the handle is perpendicular with the pipeline and the handle has contacted the handle stop.
- A handle lock is incorporated into the handle

DISASSEMBLY OF VALVE

- Remove valve from pipeline.
- Place valve in its fully open position. Remove end cap (Item #2) of valve.
- Close valve. Remove seats (Item #8), Joint Gasket (Item #13), and Ball (Item #3).
- Remove Stem Nut (Item #5), Lock Washer (Item #6), Handle (Item #7), Gland Nut (Item #9). Remove Stem (Item #4) by holding the bottom of the stem and pushing the stem through the Body (Item #1).
- Remove Thrust Washer (Item #11).
- Examine all parts for damage. If there is damage to any parts, these parts shall be replaced when reassembling valve to ensure proper operation of valve.

RE-ASSEMBLY OF VALVE

- Place new thrust washer (Item #11) onto Stem (Item #4) and place Stem into valve.
- Re-install Gland Nut (Item #9) and tighten to the torques listed in Table A.

Installation & Maintenance Manual

- Re-install one Seat (Item #8) into the valve. Place Ball (Item #3) into Body (#1). Then install second Seat and Joint Gasket (Item #13) into Body.
- Re-install End Cap (Item #2) and tighten End Cap onto Body.
- Re-install Handle (Item #7), Lock Washer (Item #6), and Stem Nut (Item #5).

| Size | Torque (in*lbs) |
|-------------|-----------------|
| 1/2" - 3/4" | 90 |
| 1" | 120 |
| 1-1/2" | 225 |
| 2" - 2-1/2" | 310 |
| 3" | 400 |

Table A: Gland Nut Torque

Series 20 Bill of Materials

MATERIALS LIST

| NO. | PART NAME | QTY | MATERIAL |
|-----|----------------|-----|--|
| 1 | BODY | 1 | ASTM A351 Gr. CF8M |
| 2 | END CAP | 1 | ASTM A351 Gr. CF8M |
| 3 | BALL | 1 | 1/8"~3/8" ASTM A276 SS316 1/2"~4" ASTM A351Gr. CF8M |
| 4 | STEM | 1 | ASTM A276 SS316 |
| 5 | STEM NUT | 1 | AISI 304 |
| 6 | LOCKWASHER | 1 | AISI 304 |
| 7 | HANDLE | 1 | AISI 304 |
| 8 | SEAT | 2 | PTFE |
| 9 | GLAND NUT | 1 | AISI 304 |
| 10 | V-RING PACKING | § | PTFE |
| 11 | THRUST WASHER | 1 | PTFE |
| 12 | HANDLE SLEEVE | 1 | VINYL |
| 13 | JOINT GASKET | 1 | PTFE |
| 14 | LOCKING DEVICE | 1 | AISI 304 |

§ REGULAR 1pc STEM PACKING IS USED FOR 1/4" & 3/8"
1 SET OF V-RING PACKING CONSISTS OF 2pcs OF V-RING FOR 1/2" - 3"

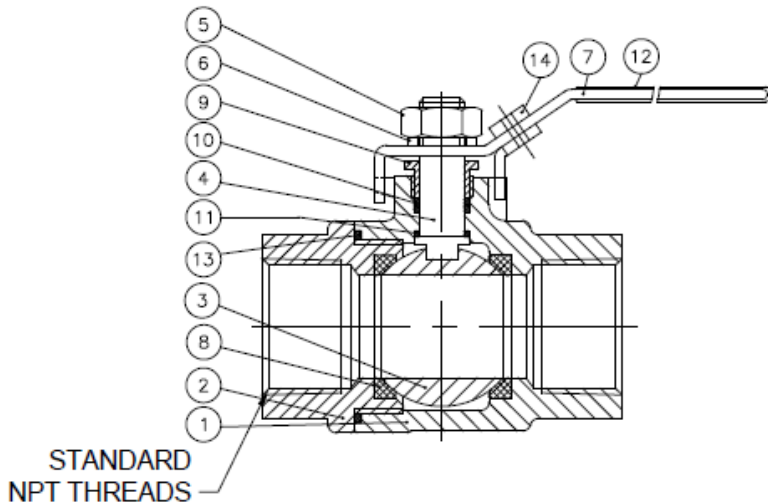

Series 21 Bill of Materials

MATERIALS LIST

| NO. | PART NAME | QTY | MATERIAL |
|-----|----------------|-----|--|
| 1 | BODY | 1 | ASTM A216 Gr.WCB |
| 2 | END CAP | 1 | ASTM A216 Gr.WCB |
| 3 | BALL | 1 | 1/4"-1/2" ASTM A276 SS316 3/4"-2" ASTM A351 GR.CPBM |
| 4 | STEM | 1 | ASTM A276 SS316 |
| 5 | STEM NUT | 1 | AISI 304 |
| 6 | *LOCKWASHER | 1 | AISI 304 |
| 7 | HANDLE | 1 | AISI 304 |
| 8 | SEAT | 2 | RTFE |
| 9 | GLAND NUT | 1 | AISI 304 |
| 10 | V-RING PACKING | § | PTFE |
| 11 | THRUST WASHER | 1 | PTFE |
| 12 | HANDLE SLEEVE | 1 | VINYL |
| 13 | JOINT GASKET | 1 | PTFE |
| 14 | LOCKING DEVICE | 1 | AISI 304 |

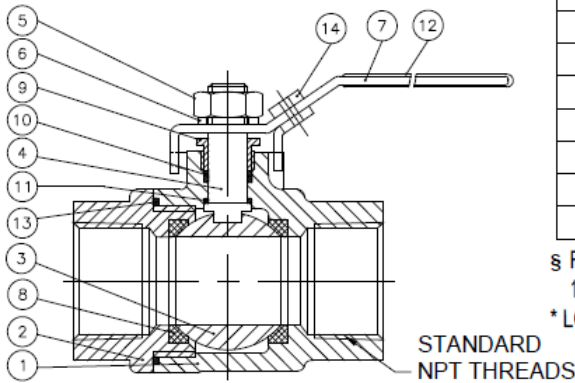

§ REGULAR 1pc STEM PACKING IS USED FOR 1/4" & 3/8"
1 SET OF V-RING PACKING, CONSISTS OF 2pcs OF V-RING FOR 1/2" & 2"
* LOCKWASHER ON VALVES EXCEPT OF 1/4" & 3/8"

A-T Controls product, when properly selected, is designed to perform its intended function safely during its useful life. However, the purchaser or user of A-T Controls products should be aware that A-T Controls products might be used in numerous applications under a wide variety of industrial service conditions. Although A-T Controls can provide general guidelines, it cannot provide specific data and warnings for all possible applications. The purchaser / user must therefore assume the ultimate responsibility for the proper sizing and selection, installation, operation, and maintenance of A-T Controls products. The user should read and understand the installation operation maintenance (IOM) instructions included with the product and train its employees and contractors in the safe use of A-T Controls products in connection with the specific application.

While the information and specifications contained in this literature are believed to be accurate, they are supplied for informative purposes only. Because A-T Controls is continually improving and upgrading its product design, the specifications, dimensions and information contained in this literature are subject to change without notice. Should any question arise concerning these specifications, the purchaser/user should contact A-T Controls.

For product specifications go to <http://download.a-tcontrols.com/>

A-T Controls, Inc. • 9955 International Boulevard, Cincinnati, OH 45246 • Phone: (513) 530-5175 • Fax: (513) 247-5462 • www.atcontrols.com