

SERIES 93

Dimensions																
SIZE	ØA	L	D	C	ØI	ØJ	ØN	T	F	NN	ØQ	ØDD	B	E	AD	Z
6"	6.00	15.51	6.42	21.00	8.50	9.51	10.98	1.00	0.06	8	0.866	4.921	0.906	2.64	1.339	4x 1/2" UNC
8"	8.00	17.99	8.94	N/A	10.63	11.75	13.50	1.13	0.06	8	0.866	4.921	0.906	2.64	1.339	4 X 1/2" UNC
10"	9.84	20.98	10.63	N/A	12.76	14.25	15.98	1.21	0.06	12	0.984	5.512	1.378	3.86	1.969	4 X 5/8" UNC
12"	11.81	24.02	13.23	N/A	15.00	17.01	19.02	1.25	0.06	12	0.984	5.512	1.378	3.86	1.969	4 X 5/8" UNC

MATERIALS LISTED ARE FOR THE STANDARD CONFIGURATION, OTHER MATERIALS ARE AVAILABLE UPON REQUEST

* SERIES 93 PRESSURE RATINGS:
 STAINLESS STEEL 275 PSI (CLASS 150)
 CARBON STEEL 285 PSI (CLASS 150)

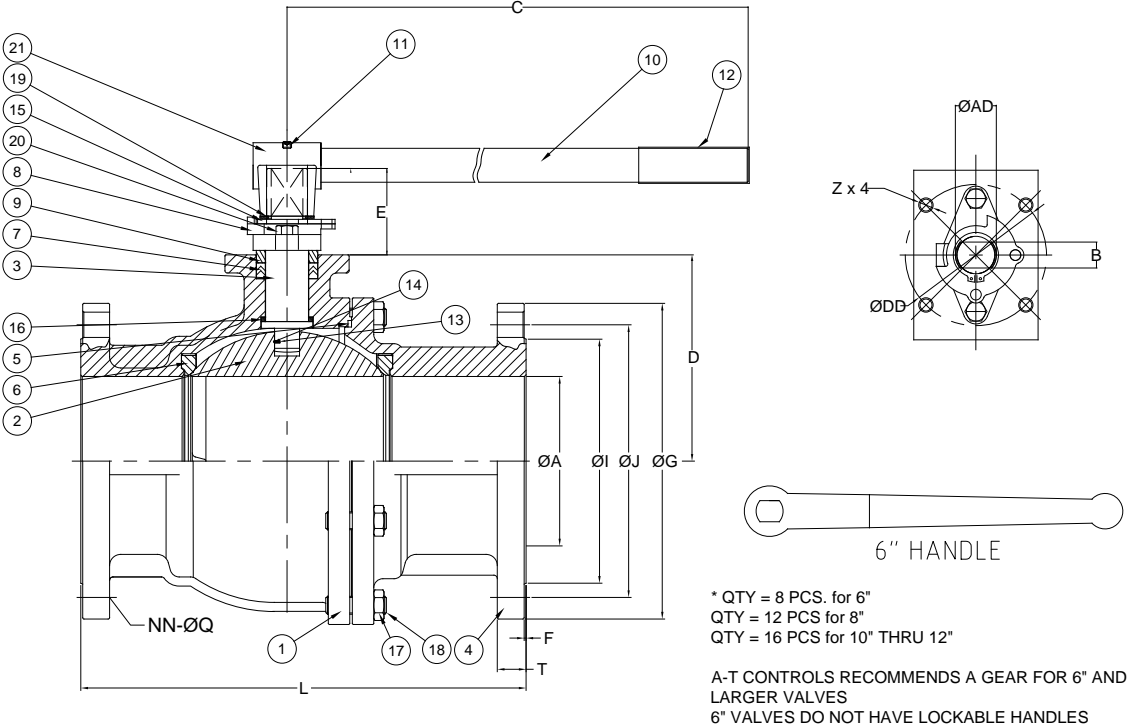

Materials					
NO.	Part Name	QTY	Stainless Steel	Carbon Steel	Repair Kit
1	BODY	1	ASTM A351 GRADE CF8M	ASTM A216 GRADE WCB	
2	BALL	1	ASTM A351 GRADE CF8M	ASTM A351 GRADE CF8M	
3	STEM	1	17-4PH	17-4PH	
4	END CAP	2	ASTM A351 GRADE CF8M	ASTM A216 GRADE WCB	
5	BODY SEAL	1	PTFE	PTFE	✓
6	SEAT	2	RTFE	RTFE	✓
7	STEM PACKING	1	PTFE	PTFE	✓
8	GLAND	1	ASTM A351 GRADE CF8	ASTM A351 GRADE CF8	
9	GLAND BUSH	1	AISI 304	AISI 304	
10	HANDLE	1	CAST IRON	CAST IRON	
11	SET BOLT	1	AISI 304	AISI 304	
12	HANDLE COVER	1	VINYL	VINYL	
13	PLUNGER SPRING	1	AISI 316	AISI 316	
14	ANTI-STATIC BALL	1	AISI 316	AISI 316	
15	STOP PLATE	1	AISI 304	AISI 304	
16	THRUST WASHER	1	RTFE	RTFE	✓
17	BODY BOLT	*	ASTM A193 GRADE B8	ASTMA193 GRADE B7	
18	BOLT NUT	*	ASTM A194 GRADE 8	ASTMA194 GRADE 2H	
19	SNAP RING	1	AISI 304	AISI 304	
20	GLAND BOLT	1	AISI 304	AISI 304	
21	HANDLE HUB	1	AISI 304	AISI 304	

	9955 INTERNATIONAL BLVD. CINCINNATI, OHIO 45246 PHONE: (513) 247-5465 FAX: (513) 247-5462	TOLERANCE UNLESS OTHERWISE SPECIFIED: TWO PLACE DECIMAL DIM. #0.02 THREE PLACE DECIMAL DIM. #0.010 ANGULAR DIM. #0°-30'	DRAWN BY CMB CHECKED BY NPM RELEASED BY NPM	HEAT # MATERIAL	SHEET 1 of 1	
	DO NOT SCALE DRAWING 	DESCRIPTION 93 Series Bill of Materials (BOM) CATALOG	DATE 06/12/20 DATE 03/18/20 DATE 03/18/20	DRAWING NO. P03551	REVISION	
	THE DESIGN AND DISCLOSURE CONTAINED IN THIS DRAWING WAS ORIGINATED BY, AND IS EXCLUSIVE PROPERTY OF A-T CONTROLS, INC. IT IS FURNISHED FOR VENDOR INFORMATION ONLY AND IS NOT AN AUTHORIZATION OR LICENSE TO MAKE THIS CONSTRUCTION OR TO FURNISH THIS INFORMATION TO OTHERS. ALL DRAWINGS MUST BE RETURNED TO A-T CONTROLS, INC. ON DEMAND. THIS DRAWING IS NOT TO BE REPRODUCED OR COPIED IN ANY FORM WITHOUT THE EXPRESS WRITTEN PERMISSION OF A-T CONTROLS, INC.					