

SEE DRAWING M04274 OR TAG ON DECLUTCH PIN FOR BASIC OPERATING INSTRUCTIONS.
FOR DETAILED OPERATING INSTRUCTIONS SEE IOM08184.

TURN HANDWHEEL CLOCKWISE FOR CLOCKWISE OUTPUT SHAFT ROTATION WHEN VIEWED
FROM ACTUATOR SIDE.

UNIT WEIGHS 154 POUNDS

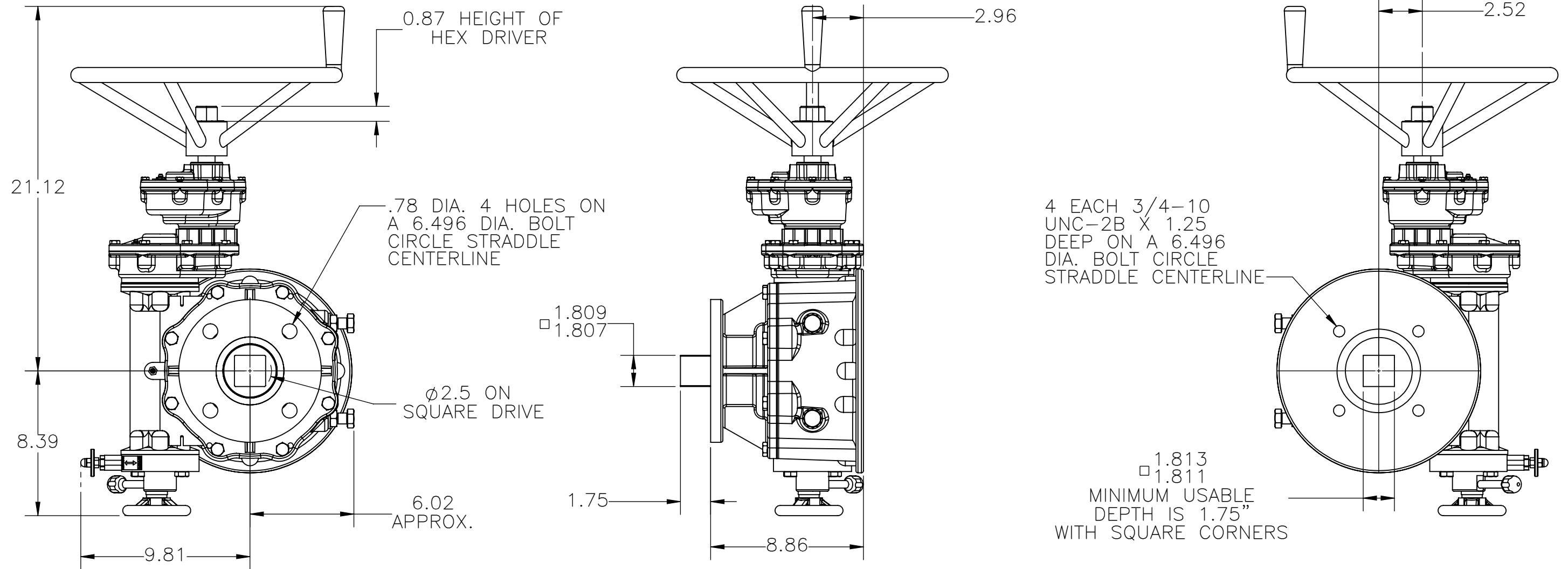

9955 INTERNATIONAL BLVD.
CINCINNATI, OHIO 45246
PHONE: (513) 247-5465
FAX: (513) 247-5462

DRAWN BY CHS	CHECKED BY KWT	RELEASED BY KWT
DATE 02/16/23	DATE 02/16/23	DATE 02/16/23

VALVES, ACTUATORS, AND AUTOMATION CONTROLS

SHEET 1 of 1

DO NOT SCALE DRAWING

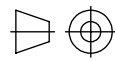

DESCRIPTION
3RDGO-46B DIMENSIONAL DRAWING FOR CUSTOMER USE.

MATERIAL

DRAWING NO. REVISION

P04475

A

THE DESIGN AND DISCLOSURE CONTAINED IN THIS DRAWING WAS ORIGINATED BY, AND IS EXCLUSIVE PROPERTY OF A-T CONTROLS, INC. IT IS FURNISHED FOR VENDOR INFORMATION ONLY AND IS NOT AN AUTHORIZATION OR LICENSE TO MAKE THIS CONSTRUCTION OR TO FURNISH THIS INFORMATION TO OTHERS. ALL DRAWINGS MUST BE RETURNED TO A-T CONTROLS, INC. ON DEMAND. THIS DRAWING IS NOT TO BE REPRODUCED OR COPIED IN ANY FORM WITHOUT THE EXPRESS WRITTEN PERMISSION OF A-T CONTROLS, INC.