

SEE DRAWING M02474 OR TAG ON DECLUTCH PIN FOR BASIC OPERATING INSTRUCTIONS.
FOR DETAILED OPERATING INSTRUCTIONS SE IOM08183.

TURN HANDWHEEL CLOCKWISE FOR CLOCKWISE OUTPUT SHAFT ROTATION WHEN VIEWED FROM ACTUATOR SIDE.

UNIT WEIGHS 154 LBS

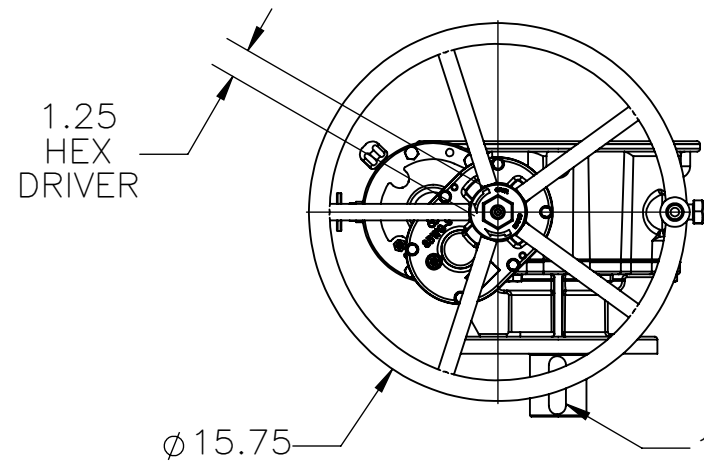

18X11MM KEYWAY
ONE PLACE SHOWN IN THE
FULL CLOCKWISE POSITION
WHEN VIEWED FROM ACTUATOR SIDE.
MAY BE MOVED IN 90 DEGREE INCREMENTS.

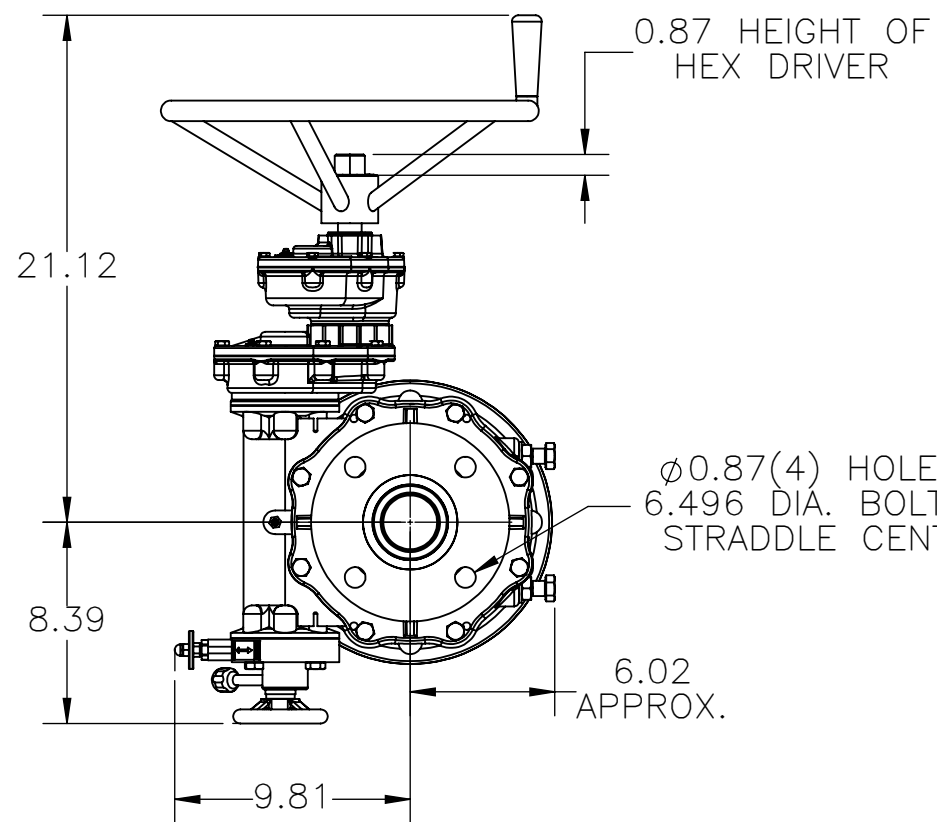

0.87 HEIGHT OF
HEX DRIVER

21.12

8.39

9.81

6.02
APPROX.

0.87(4) HOLES ON A
6.496 DIA. BOLT CIRCLE
STRADDLE CENTERLINE

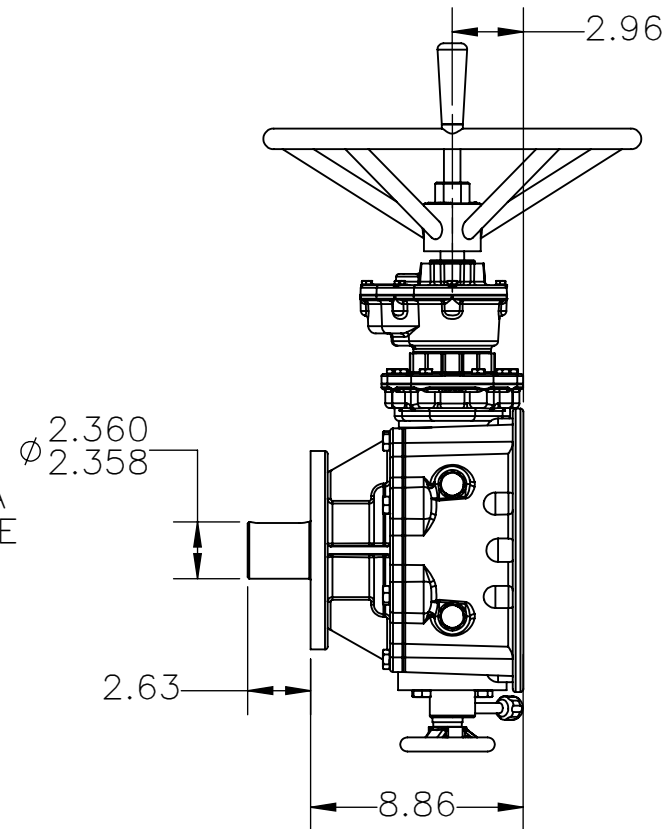

2.96

2.360
2.358

2.63

8.86

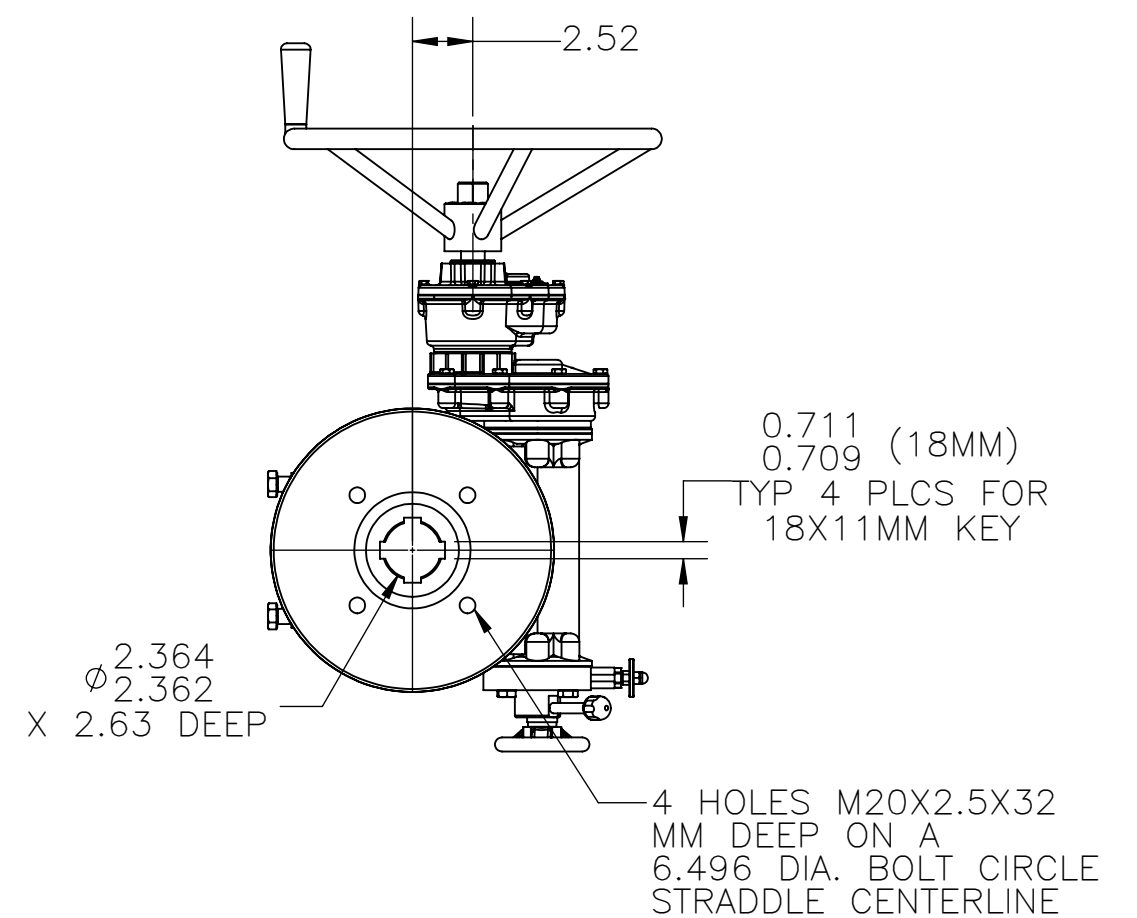

2.52

0.711
0.709 (18MM)

2.364
2.362
X 2.63 DEEP

4 HOLES M20X2.5X32
MM DEEP ON A
6.496 DIA. BOLT CIRCLE
STRADDLE CENTERLINE

TYP 4 PLCS FOR
18X11MM KEY



9955 INTERNATIONAL BLVD.
CINCINNATI, OHIO 45246
PHONE: (513) 247-5465
FAX: (513) 247-5462

DRAWN BY CHS	CHECKED BY KWT	RELEASED BY KWT
DATE 02/16/23	DATE 02/16/23	DATE 02/16/23

VALVES, ACTUATORS, AND AUTOMATION CONTROLS

SHEET 1 of 1

DO NOT SCALE DRAWING

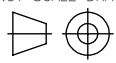

DESCRIPTION
3DGO-S09A DIMENSIONAL DRAWING FOR CUSTOMER USE.

MATERIAL

DRAWING NO. REVISION

P04477

A

THE DESIGN AND DISCLOSURE CONTAINED IN THIS DRAWING WAS ORIGINATED BY, AND IS EXCLUSIVE PROPERTY OF A-T CONTROLS, INC. IT IS FURNISHED FOR VENDOR INFORMATION ONLY AND IS NOT AN AUTHORIZATION OR LICENSE TO MAKE THIS CONSTRUCTION OR TO FURNISH THIS INFORMATION TO OTHERS. ALL DRAWINGS MUST BE RETURNED TO A-T CONTROLS, INC. ON DEMAND. THIS DRAWING IS NOT TO BE REPRODUCED OR COPIED IN ANY FORM WITHOUT THE EXPRESS WRITTEN PERMISSION OF A-T CONTROLS, INC.