



Contents

1. SCOPE	2
2. INSTALLATION	2
3. VALVE OPERATION	2
4. DISASSEMBLY	3
5. ASSEMBLY	3
6. REPAIR KITS	4
7. BILL OF MATERIALS	5

1. SCOPE

1.1. CAUTION

- 1.1.1. For your safety, read this manual before installation or service.
- 1.1.2. Before installing or servicing, please ensure the line pressure has been relieved and any hazardous fluids have been drained or purged from the system.
- 1.1.3. Ensure that all Lockout and Tagout procedures for the system have been properly implemented.

1.2. USE

- 1.2.1. Maximum results and long life of valves can be maintained under normal working conditions and according with pressure/temperature ratings.

2. INSTALLATION

2.1. GENERAL INFORMATION FOR INSTALLATION

- 2.1.1. The valve can be installed in any position on the pipeline.
- 2.1.2. Before installation of the valve, the pipe must be flushed clean of dirt, burrs, and welding residue or the seats and ball surface will be damaged. The pipe must be free from tension and in proper alignment. Check to ensure that all connections are free from defects.

2.2. INSTALLATION OF FLANGED ENDS

- 2.2.1. Carefully align serrated gaskets on each end of the valve and insert the valve into pipeline. Ensure that bolt holes on valve line up with bolt holes on the pipeline. Insert flange bolts and nuts on the ends of the valve and tighten evenly in a star pattern. Consult with the gasket manufacturer for the proper bolt torque.

3. VALVE OPERATION

3.1. MANUAL

3.1.1. HANDLE

- 3.1.1.1. To OPEN the valve, turn the handle counterclockwise until the handle is parallel with the pipeline and the handle has contacted the handle stop.
- 3.1.1.2. To CLOSE the valve, turn the handle clockwise until the handle is perpendicular with the pipeline and the handle has contacted the handle stop.
- 3.1.1.3. A handle lock is incorporated into the handle.

3.1.1.3.1. For sizes up to 2-1/2": To use, slide the lock into the mounting pad, in the full open or full closed position. Insert an appropriate size lock or hasp into the hole in the handle. If it can be performed safely, try to turn the handle to ensure that the valve has been locked properly.

3.1.1.3.2. For sizes larger than 2-1/2": To use, turn the handle to the full open or full closed position. Insert an appropriate size lock or hasp into the hole in the handle and through the mounting pad. If it can be performed safely, try to turn the handle to ensure that the valve has been locked properly.

3.1.2. GEAR

3.1.2.1. To OPEN the valve, turn the hand wheel counterclockwise. The indicator will be pointing to the open position and the hand wheel will stop rotating when fully opened. The flow can be adjusted by stopping the indicator anywhere between open and close.

3.1.2.2. To CLOSE the valve, turn the handwheel clockwise. The indicator will be pointing to the close position and the hand wheel will stop rotating when fully closed. The flow can be adjusted by stopping the indicator anywhere between open and close.

3.2. AUTOMATED

3.2.1. A-T Controls D9 Series Ball Valves can be mounted with quarter-turn actuators. Valves with actuators shall be checked for proper valve stem alignment. Angular or linear misalignment may result in high operational torque and unnecessary wear on the valve stem. See the actuator IOM for information on operating the actuator.

4. DISASSEMBLY

!!! WARNING !!!

CAUTION, FLUIDS CAN BE TRAPPED IN THE BODY OF THE VALVE, POSSIBLY UNDER HIGH PRESSURE. FOR YOUR SAFETY, IT IS IMPORTANT THAT PRECAUTIONS ARE TAKEN BEFORE REMOVAL OF THE VALVE FROM THE LINE OR ANY DISASSEMBLY.

- 4.1. Remove actuator or gear if equipped.
- 4.2. Care should be taken to not damage the surface finish of the valve components.
- 4.3. Remove the end cap (2) by removing the body nuts (17).
- 4.4. Remove the seats (4) and body gasket (5) from the body (1). Once removed, with the valve in the fully closed position, the ball (3) should slide freely out of the body (1).
- 4.5. If equipped, remove the handle nut (24), handle (15), and the handle stop assembly (19 & 20).
- 4.6. While holding the stem (6) stationary, remove the packing nut (13). Once removed, the locking saddle (12), Belleville washers (11), and the packing bushing (10) should be free to remove.
- 4.7. While holding the bottom of the stem (6), push the stem (6) through the inside of the valve body (1).
- 4.8. Remove the packing set (8) and the stem seal (7).
- 4.9. Inspect all components for damage and, if necessary, clean or replace.

5. ASSEMBLY

- 5.1. Care should be taken to not damage the surface finish of the valve components.
- 5.2. Place stem seal (7) on the stem (6) and install it by going through the body (1). Insert V-style packing set (8) over stem (6) with the V pointing away from the valve (see Bill of Materials for correct orientation).
- 5.3. Install the packing gland (8) Belleville washers (11), locking saddle (12), and the packing nut (13). While holding the stem (6), tighten the packing nut (13) to the torque listed in the Fastener Torque Chart. Tighten further if needed in order to be able to bend the locking saddle (12) over the packing nut (13).

- 5.4. Ensure the stem (6) is in the closed position with the body tang parallel with the flow of the valve. Carefully slide the ball (3) into the body (1) and insert the seat (4) and body gasket (5).
- 5.5. Assemble end cap (2) onto the body (1). Insert all body studs (18) and nuts (17) into the valve and tighten to finger tight, making sure that the end (2) is flat against the body (1). Tighten all nuts (17) to the final torque in a star pattern. Check each body bolt (18) torque and tighten if needed a final time. It is acceptable for the torque to relax slightly over time due to relaxation of the polymer components, but the valve will still seal properly. If leakage is detected, repeat steps for tightening the body bolts (18).
- 5.6. If required, assemble the locking device (21), handle stop assembly (19 & 20), handle (15), and the handle nut (24).

Fastener Torque Chart			
Valve Size	50% of Max Torque of Body Bolts (In-lbs.)	Max Torque of Body Bolts (In-lbs.)	Max Torque of Stem Nut (In-lbs.)
1/2"	100	200	122
3/4"	109	217	122
1"	143	286	122
1-1/2"	152	304	191
2"	196	391	191
2-1/2"	196	391	191
3"	261	521	278
4"	261	521	278
6"	261	521	365
8"	600	1200	365
10"	600	1200	365
12"	600	1200	365

6. REPAIR KITS

Repair kits are available to replace all soft goods. See Bill of Materials for components that are included in the repair kits.

7. BILL OF MATERIALS

NO.	PART NAME	QTY	REPAIR KIT
1	BODY	1	
2	END CAP	1	
3	BALL	1	
4	SEAT	2	x
5	JOINT GASKET	1	x
6	STEM	1	
7	STEM SEAL	1	
8	GLAND PACKING	1	x
9	GLAND WASHER	1	x
10	GLAND BUSHING	1	
11	BELLEVILLE WASHER	2	
12	LOCK SADDLE	1	
13	STEM NUT	1	
14	STEM WASHER	1	
15	HANDLE	1	
16	HANDLE SLEEVE	1	
17	BODY NUT	1	
18	BODY STUD	*	
19	STOP BOLT	1	
20	STOP BOLT NUT	1	
21	HANDLE LOCK	1	
22	STEM O-RING	1	
23	ANTI-STATIC DEVICE	2	
24	HANDLE NUT	1	
* 1/2" THRU 2" QTY = 4 PCS			
* 2-1/2" THRU 4" QTY = 8 PCS			
* 6" QTY = 10 PCS			
* 8" QTY = 12 PCS			

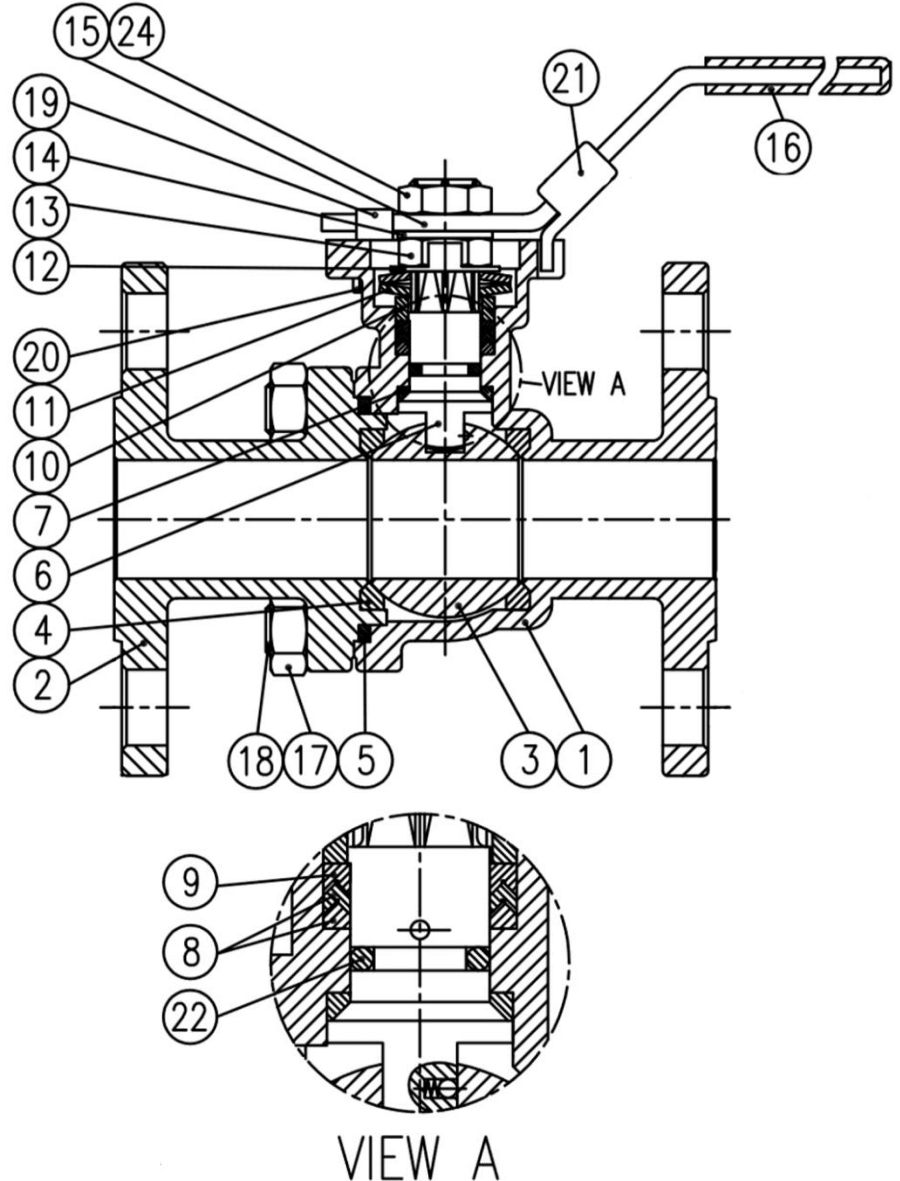

A-T Controls product, when properly selected, is designed to perform its intended function safely during its useful life. However, the purchaser or user of A-T Controls products should be aware that A-T Controls products might be used in numerous applications under a wide variety of industrial service conditions. Although A-T Controls can provide general guidelines, it cannot provide specific data and warnings for all possible applications. The purchaser / user must therefore assume the ultimate responsibility for the proper sizing and selection, installation, operation, and maintenance of A-T Controls products. The user should read and understand the installation operation maintenance (IOM) instructions included with the product and train its employees and contractors in the safe use of A-T Controls products in connection with the specific application.

While the information and specifications contained in this literature are believed to be accurate, they are supplied for informative purposes only. Because A-T Controls is continually improving and upgrading its product design, the specifications, dimensions and information contained in this literature are subject to change without notice. Should any question arise concerning these specifications, the purchaser/user should contact A-T Controls.

For product specifications go to <https://a-tcontrols.com/Downloads/>

A-T Controls, Inc. • 9955 International Boulevard, Cincinnati, OH 45246 • Phone: (513) 530-5175 • Fax: (513) 247-5462 • www.atcontrols.com