

**API 607 - 7th Edition
CERTIFIED**



Triac Series F9R unibody flanged ball valves feature a high quality investment cast body and end. They are available in 1/2" through 8" regular port. Double seal design (1-1/2"-8") provides superior leak protection. Packing is adjustable without removal of actuator.

TFM™-1600 seats are standard, but various options are available for seat materials. The 50/50 TFM™/SS (STFM) seat option is excellent for services that call for higher temperatures and more difficult applications including steam. Call us for details.

HOW TO ORDER MANUAL VALVES

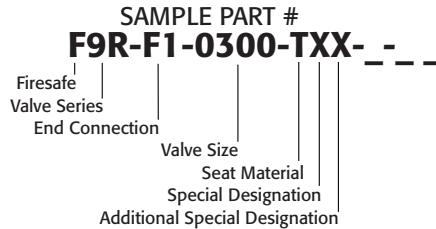

See part number matrix for itemized options.

Easy to Automate!

See automated data sheets for pre-sized assemblies



Pneumatic



Electric



Series F9R

FIRESAFE

**Unibody Direct Mount
Flanged Ball Valve**

Sizes 1/2" – 8"

Available in 316SST or WCB

ASME Class 150

Regular Port Design

Superior Live Loaded Packing System

ISO 5211 Actuator Mounting Pad

Blowout Proof Stem w/
Anti-Static Devices

TFM™-1600 Seats Standard

Contained Graphite

Lockable Manual Handle

Adjustable Packing w/o Actuator
Disassembly

STANDARDS

Design	ASME B16.34 (fully conforms)
Face to Face	ASME B16.10
Flange Dimensions	ASME B16.5
Pressure Testing	API 598
Fire Testing	API 607-7th Edition
Fugitive Emissions	ISO 15848-1
	ISO FE BH - C03 - SSAO - T200°C - Class 300 - ISO 15848-1
Sulfide Stress Protection	NACE MR0175/MR0103
Mounting	ISO 5211
Marking System for Valves	MSS SP-25
Material Certification	EN 10204-3.1 MTR
Quality Assurance	ISO 9001:2015

TABLE OF CONTENTS:

- Page 2 - Materials & Dimensions
- Page 3 - Technical Data
- Page 4 - Double Acting
- Page 5 - Spring Return
- Page 6 - Electric
- Page 7 - How to Order - Manual
- Page 8 - How to Order - Automated

SERIES F9R Unibody Flanged Ball Valve

Firesafe



9955 International Blvd.
Cincinnati, Ohio 45246
www.atcontrols.com

PHONE (513) 247-5465
FAX (513) 247-5462
sales@atcontrols.com

API 607 - 7th Edition
CERTIFIED

MATERIALS LIST					
NO.	PART NAME	QTY	STAINLESS STEEL	CARBON STEEL	REPAIR KIT
1	BODY	1	ASTM A351 GRADE CF8M	ASTM A216 GRADE WCB	
2	RETAINER	1	ASTM A351 GRADE CF8M	ASTM A216 GRADE WCB	
3	BALL	1	ASTM A351 GRADE CF8M	ASTM A351 GRADE CF8M	
4	STEM	1	AISI 316 (1/2"-4")	AISI 316 (1/2"-4")	
		1	17-4 PH® (6" & 8")	17-4 PH® (6" & 8")	
5	SEAT	2	TFM™-1600	TFM™-1600	✓
6	BODY SEAL 1	1	TFM™-1600 (1-1/2"-8")	TFM™-1600 (1-1/2"-8")	✓
7	BODY SEAL 2	1	GRAPHITE (1/2"-1")	GRAPHITE (1/2"-1")	✓
		1	GRAPHITE + 316 (1-1/2"-8")	GRAPHITE + 316 (1-1/2"-8")	✓
8	THRUST WASHER	1	RTFE	RTFE	✓
9	STEM PACKING	1	GRAPHITE + MG1241	GRAPHITE + MG1241	✓
10	STEM O-RING	*	FKM	FKM	✓
11	GLAND BUSHING	1	AISI 304	AISI 304	
12	HANDLE SPACER	1	AISI 304	AISI 304	
13	HANDLE NUT	1	AISI 304 (1/2"-2")	AISI 304 (1/2"-2")	
14	HANDLE	1	AISI 304	AISI 304	
15	STEM EXT SCREW	1	AISI 304 (1/2" & 1")	AISI 304 (1/2" & 1")	
16	HANDLE COVER	1	VINYL	VINYL	
17	STOP PLATE	1	AISI 304 (1/2"-6")	AISI 304 (1/2"-6")	
18	HANDLE NUT/BOLT	#	AISI 304 (3"-8")	AISI 304 (3"-8")	
19	ANTI-STATIC BALL	1	AISI 316	AISI 316	
20	BELLEVILLE WASHER	2	AISI 301	AISI 301	
22	GLAND BOLT/NUT	2	AISI 304	AISI 304	
23	GLAND FLANGE	1	AISI 304	AISI 304	
24	HANDLE ADAPTER	1	AISI 304 (8")	AISI 304 (8")	
25	STEM EXTENSION	1	AISI 304 (1/2" & 1")	AISI 304 (1/2" & 1")	

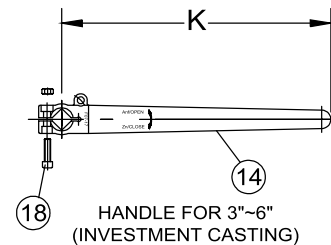
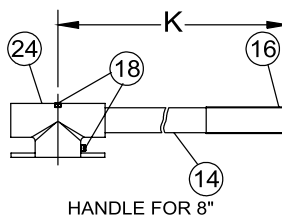
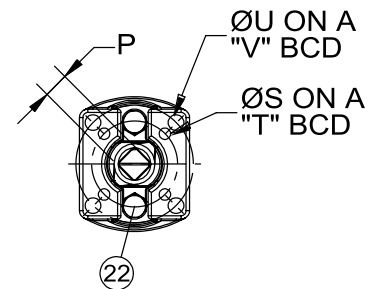
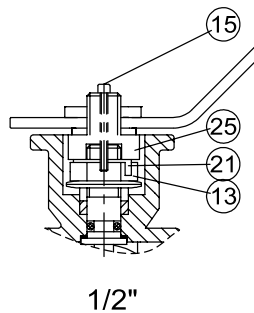
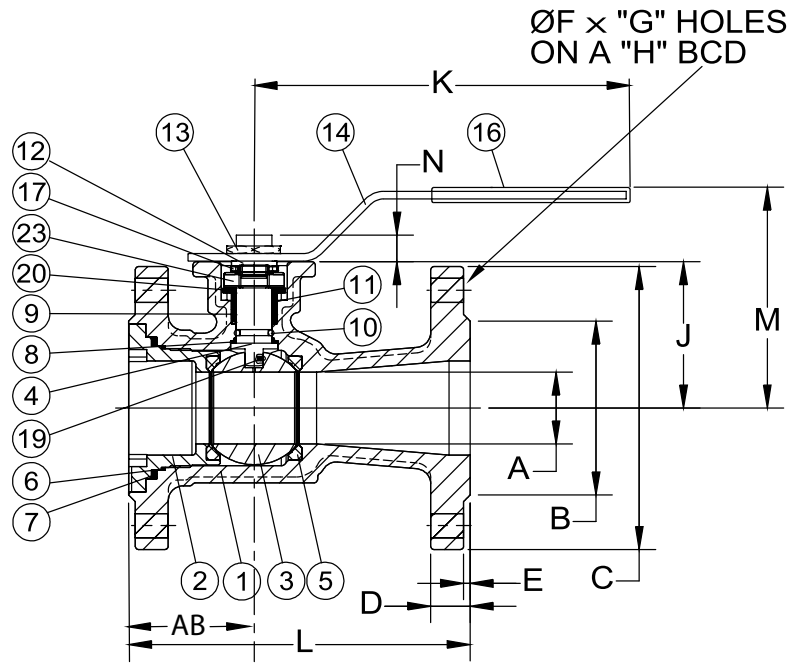

* 1/2" THRU 2-1/2" & 8" QTY=1 PC
* 3"-6" QTY=2 PCS

< 3" QTY=0 PCS
3"-6" QTY=1 PC
8" QTY=2 PCS

DIMENSIONS (IN)

SIZE	VALVE DIMENSIONS													ACTUATOR MOUNTING DIMENSIONS						WEIGHT	
	ØA	ØB	AB	ØC	D	E	F	G	ØH	J	K	L	M	N	P	S	T	U	V	ISO 5211	LBS
1/2"	0.50	1.37	2.17	3.54	0.39	0.08	0.63	4	2.38	1.91	4.72	4.25	3.46	0.46	0.354	0.24	1.417	0.24	1.654	F03/F04	3
3/4"	0.59	1.69	1.97	3.94	0.43	0.08	0.63	4	2.75	2.01	4.72	4.61	3.51	0.33	0.354	0.24	1.417	0.24	1.654	F03/F04	4
1"	0.79	2.00	2.24	4.33	0.46	0.08	0.63	4	3.13	2.50	5.98	5.00	4.02	0.44	0.433	0.24	1.654	0.28	1.969	F04/F05	5
1-1/2"	1.26	2.89	2.56	4.92	0.58	0.08	0.63	4	3.88	2.80	5.98	6.50	4.29	0.39	0.433	0.25	1.654	0.29	1.969	F04/F05	9
2"	1.50	3.63	2.56	5.91	0.64	0.08	0.75	4	4.75	3.05	7.48	7.01	4.66	0.56	0.551	0.29	1.969	0.37	2.756	F05/F07	14
2-1/2"	1.97	4.13	2.95	7.09	0.70	0.08	0.75	4	5.50	3.58	7.48	7.48	5.10	0.56	0.551	0.29	1.969	0.37	2.756	F05/F07	22
3"	2.52	5.00	3.46	7.48	0.77	0.08	0.75	4	6.00	4.49	11.81	7.99	6.78	0.68	0.669	0.37	2.756	0.44	4.016	F07/F10	30
4"	2.99	6.19	3.54	9.06	0.96	0.08	0.75	8	7.50	5.00	11.81	9.06	7.30	0.69	0.669	0.37	2.756	0.44	4.016	F07/F10	50
6"	3.86	8.50	4.53	11.02	1.02	0.08	0.88	8	9.50	6.42	11.81	10.51	8.69	0.72	0.669	0.37	2.756	0.44	4.016	F07/F10	75
8"	5.91	10.63	5.41	13.58	1.13	0.06	0.88	8	11.75	8.39	30.31	11.50	11.38	1.20	1.063	0.47	4.016	0.55	4.921	F10/F12	172

Technical Data

Series F9R

API 607 - 7th Edition
CERTIFIED

**Pressure vs. Temperature - Series F9R
Seat Ratings**

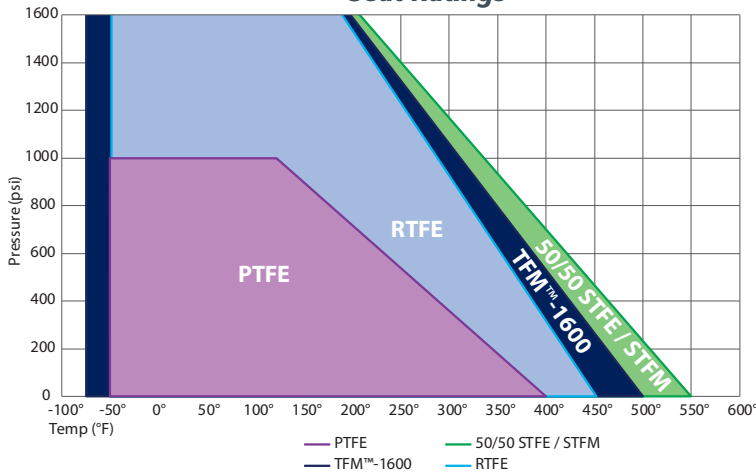

Temp	Pressure - Seat Material				
	TFM™-1600	STFM	STFE	PTFE	RTFE
-75°	2000				
-50°	2000	2000	2000	1000	2000
100°	2000	2000	2000	1000	2000
122°	2000	2000	2000	1000	2000
150°	1852	1869	1869	899	1852
200°	1587	1636	1636	719	1587
250°	1323	1402	1402	540	1323
300°	1058	1168	1168	360	1058
350°	794	935	935	180	794
400°	529	701	701	0	529
450°	265	467	467		265
500°	0	234	234		0
550°		0	0		

**Pressure vs. Temperature - Series F9R
Body Ratings**

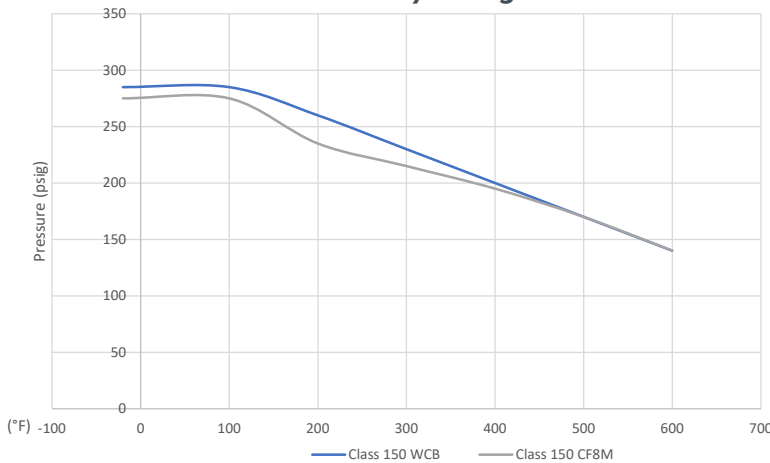

Pressure - Body Material		
Temp (°F)	WCB psi	CF8M psi
-20°	285	275
100°	285	275
200°	260	235
300°	230	215
400°	200	195
500°	170	170
600°	140	140

Component Temperature Ratings		
COMPONENT	MATERIAL	TEMPERATURE
Stem Packing	Graphite	-100°F to 1100°F
Stem Seal	TFM™-1600	-75°F to 500°F
Gaskets	Graphite	-100°F to 1100°F
	TFM™-1600	-75°F to 500°F
Seats (Other Materials Available)	TFM™-1600 (standard)	-75°F to 500°F
	STFM	-50°F to 550°F
	RTFE	-50°F to 450°F
	PTFE	-50°F to 400°F
	50/50 STFE	-50°F to 550°F
O-Rings	FKM (standard)	-20°F to 450°F
	Markez® Z1028	5°F to 608°F
	Kalrez® 4079	30°F to 600°F
	Chemraz® 505	-22°F to 446°F
	Kalrez® 6375	-4°F to 527°F
	Perlast® G75M	5°F to 500°F
	Chemraz® 564	-40°F to 445°F
	Low Temp Buna	-65°F to 275°F
	EPDM	-70°F to 250°F
Silicone	-60°F to 400°F	

Break Away Torque for TFM™-1600 Seats	
SIZE	IN-LBS.
1/2"	50
3/4"	65
1"	145
1-1/2"	200
2"	250
2-1/2"	400
3"	600
4"	1075
6"	1650
8"	2200

Published torques are based on full differential pressure with clean water. Consult The Application Sizing Guide for assistance with sizing actuators

SIZE	Cv
1/2"	8
3/4"	15
1"	44
1-1/2"	120
2"	160
2-1/2"	250
3"	350
4"	650
6"	950
8"	1875

NOTE: At temperature, valves are limited by either the valve body/end cap pressure ratings, seat pressure ratings, or packing/stem seal/gaskets; whichever is lower.

Pneumatic Double Acting

Series F9R Unibody Direct Mount Flanged Ball Valve

Firesafe

Sizes 1/2" - 8"

Available in 316SST or WCB

ASME Class 150

Regular Port Design

Superior Live Loaded Packing System

ISO 5211 Actuator Mounting Pad

Blowout Proof Stem w/
Anti-Static Devices

TFM™-1600 Seats Standard

Contained Graphite

Lockable Manual Handle

Adjustable Packing w/o Actuator
Disassembly

STANDARDS

Design	ASME B16.34 (fully conforms)
Face to Face	ASME B16.10
Flange Dimensions	ASME B16.5
Pressure Testing	API 598
Fire Testing	API 607-7th Edition
Fugitive Emissions	ISO 15848-1
	ISO FE BH - C03 - SSAO - T200°C - Class 300 - ISO 15848-1
Sulfide Stress Protection	NACE MR0175/MR0103
Mounting	ISO 5211
Marking System for Valves	MSS SP-25
Material Certification	EN 10204-3.1 MTR
Quality Assurance	ISO 9001:2015

**API 607 - 7th Edition
CERTIFIED**



**ASME Class 150 Flanged
Firesafe Tested to API 607**

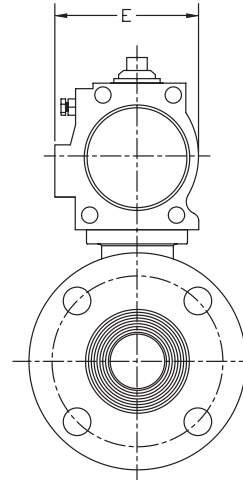
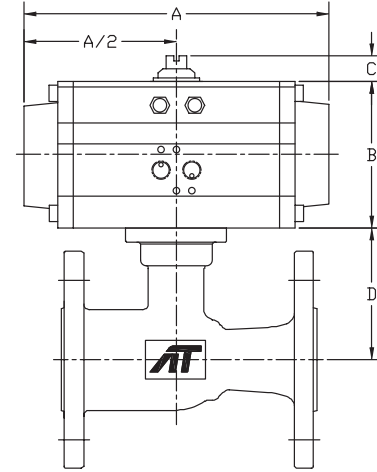

DIMENSIONS (IN)

VALVE SIZE	A	B	C	D	E	VALVE Cv
1/2"	6.50	2.84	0.787	1.91	2.82	8
3/4"	6.50	2.84	0.787	2.01	2.82	15
1"	6.50	2.84	0.787	2.50	2.82	44
1-1/2"	7.60	3.47	0.787	2.80	3.35	120
2"	7.60	3.47	0.787	3.05	3.35	160
2-1/2"	9.29	4.30	0.787	3.58	4.18	250
3"	9.29	4.30	0.787	4.49	4.18	350
4"	11.50	5.28	0.787	5.00	5.78	650
6"	13.39	6.14	0.787	6.42	5.59	950
8"	15.35	6.81	1.181	8.39	5.98	1875

DIMENSIONS SHOWN ARE FOR ASSEMBLIES SIZED FOR 80 PSI SUPPLY

**SERIES F9R Unibody Flanged
Firesafe**

SIZED FOR 80 psi AIR SUPPLY	
SIZE	MODEL
1/2"	F9R-F1-050/3RDD-XX
3/4"	F9R-F1-075/3RDD-XX
1"	F9R-F1-100/3RDD-XX
1-1/2"	F9R-F1-150/3RED-XX
2"	F9R-F1-200/3RED-XX
2-1/2"	F9R-F1-250/3RFD-XX
3"	F9R-F1-300/3RFD-XX
4"	F9R-F1-400/3RHD-XX
6"	F9R-F1-600/3RJD-XX
8"	F9R-F1-800/3RKD-XX

SIZED FOR 60 psi AIR SUPPLY	
SIZE	MODEL
1/2"	F9R-F1-050/3RDD-XX
3/4"	F9R-F1-075/3RDD-XX
1"	F9R-F1-100/3RED-XX
1-1/2"	F9R-F1-150/3RED-XX
2"	F9R-F1-200/3RFD-XX
2-1/2"	F9R-F1-250/3RFD-XX
3"	F9R-F1-300/3RGD-XX
4"	F9R-F1-400/3RHD-XX
6"	F9R-F1-600/3RJD-XX
8"	F9R-F1-800/3RKD-XX

OPTIONS

SUFFIX 1	Accessories/Options	Model no.
X	No Specials	
A	TYPE 4 Solenoid 120VAC	TVCS-X411-4N-A120
B	TYPE 7 Solenoid 120VAC	TVCS-X411-7N-A120
C	Intrinsically Safe Solenoid	TVSS-X411-4N-D24
D	TYPE 4 Solenoid 24VDC	TVCS-X411-4N-D24
F	TYPE 7 Solenoid 24VDC	TVCS-X411-7N-D24
Q	TYPE 4 SST Solenoid 120VAC	TVSS-X411-4N-A120
M	TYPE 7 SST Solenoid 120VAC	TVSS-X411-7N-A120
L	TYPE 4 SST Solenoid 24VDC	TVSS-X411-4N-D24
N	TYPE 7 SST Solenoid 24VDC	TVSS-X411-7N-D24
P	Pneumatic Positioner	PPR-1200
E	Electro-Pneumatic Positioner	EPR-1000

SUFFIX 2	Accessories	Model no.
X	No Specials	
A	TYPE 4 Limit Switch	APL-210N
B	TYPE 7 Limit Switch	APL-510N
C	Intrinsically Safe Limit Switch	APL-218N
Q	TYPE 4 SST Limit Switch	APL-910N
M	TYPE 7 SST Limit Switch	APL-510S
H	NEMA 4 Std. Enc.	APL-310N

NOTE: Heater and thermostat standard
(2) auxiliary switches standard

Other options available - call for details
Actuators are sized based on full
differential pressure with clean water.
Consult the Application Sizing Guide
for assistance with sizing actuators.

SAMPLE PART # F9RC-F1-150/3RED-XX

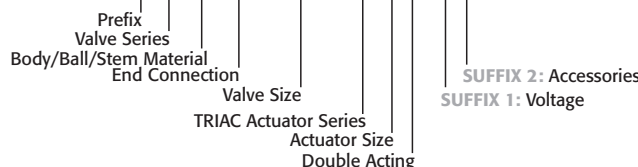

See automated part number matrix
on back cover for complete part
number and options.

Pneumatic Spring Return

Series F9R Unibody Direct Mount Flanged Ball Valve

Firesafe

Sizes 1/2" - 8"

Available in 316SST or WCB

ASME Class 150

Regular Port Design

Superior Live Loaded Packing System

ISO 5211 Actuator Mounting Pad

Blowout Proof Stem w/
Anti-Static Devices

TFM™-1600 Seats Standard

Contained Graphite

Lockable Manual Handle

Adjustable Packing w/o Actuator
Disassembly

STANDARDS

Design	ASME B16.34 (fully conforms)
Face to Face	ASME B16.10
Flange Dimensions	ASME B16.5
Pressure Testing	API 598
Fire Testing	API 607-7th Edition
Fugitive Emissions	ISO 15848-1
	ISO FE BH - C03 - SSAO - T200°C - Class 300 - ISO 15848-1
Sulfide Stress Protection	NACE MR0175/MR0103
Mounting	ISO 5211
Marking System for Valves	MSS SP-25
Material Certification	EN 10204-3.1 MTR
Quality Assurance	ISO 9001:2015

**API 607 - 7th Edition
CERTIFIED**



**ASME Class 150 Flanged
Firesafe Tested to API 607**

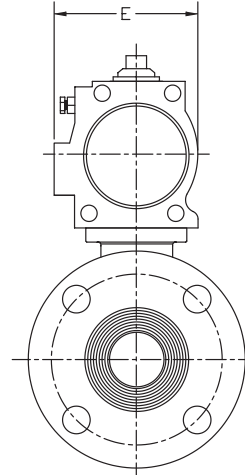
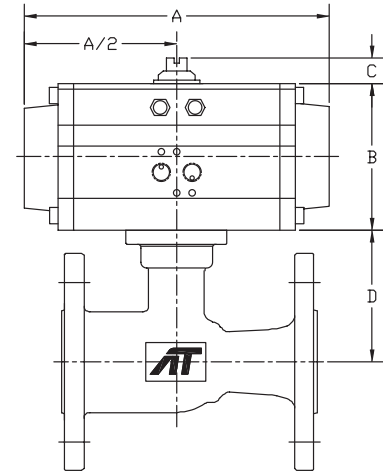

DIMENSIONS (IN)

VALVE SIZE	A	B	C	D	E	VALVE Cv
1/2"	6.50	2.84	0.787	1.91	2.82	8
3/4"	7.60	3.47	0.787	2.01	3.35	15
1"	9.29	4.30	0.787	2.50	4.18	44
1-1/2"	9.29	4.30	0.787	2.80	4.18	120
2"	11.02	4.61	0.787	3.05	4.27	160
2-1/2"	11.50	5.28	0.787	3.58	5.78	250
3"	13.39	6.14	0.787	4.49	5.59	350
4"	15.35	6.81	1.181	5.00	5.98	650
6"	16.89	7.36	1.181	6.42	6.38	950
8"	19.37	7.81	1.181	8.39	6.85	1875

DIMENSIONS SHOWN ARE FOR ASSEMBLIES SIZED FOR 80 PSI SUPPLY

SERIES F9R Unibody Flanged

Firesafe

SIZED FOR 80 psi AIR SUPPLY	
SIZE	MODEL
1/2"	F9R-F1-050/3RDS-XX
3/4"	F9R-F1-075/3RES-XX
1"	F9R-F1-100/3RFS-XX
1-1/2"	F9R-F1-150/3RFS-XX
2"	F9R-F1-200/3RGS-XX
2-1/2"	F9R-F1-250/3RHS-XX
3"	F9R-F1-300/3RJS-XX
4"	F9R-F1-400/3RKS-XX
6"	F9R-F1-600/3RLS-XX
8"	F9R-F1-800/3RMS-XX

SIZED FOR 60 psi AIR SUPPLY	
SIZE	MODEL
1/2"	F9R-F1-050/3RD4-XX
3/4"	F9R-F1-075/3RE4-XX
1"	F9R-F1-100/3RF4-XX
1-1/2"	F9R-F1-150/3RG4-XX
2"	F9R-F1-200/3RG4-XX
2-1/2"	F9R-F1-250/3RH4-XX
3"	F9R-F1-300/3RJ4-XX
4"	F9R-F1-400/3RK4-XX
6"	F9R-F1-600/3RM4-XX
8"	F9R-F1-800/3RN4-XX

OPTIONS		
SUFFIX 1	Accessories/Options	Model no.
X	No Specials	
A	TYPE 4 Solenoid 120VAC	TVCS-X411-4N-A120
B	TYPE 7 Solenoid 120VAC	TVCG-X411-7N-A120
C	Intrinsically Safe Solenoid	TVIS-X411-4N-D24
D	TYPE 4 Solenoid 24VDC	TVCS-X411-4N-D24
F	TYPE 7 Solenoid 24VDC	TVCG-X411-7N-D24
Q	TYPE 4 SST Solenoid 120VAC	TVSS-X411-4N-A120
M	TYPE 7 SST Solenoid 120VAC	TVSS-X411-7N-A120
L	TYPE 4 SST Solenoid 24VDC	TVSS-X411-4N-D24
N	TYPE 7 SST Solenoid 24VDC	TVSS-X411-7N-D24
P	Pneumatic Positioner	PPR-1200
E	Electro-Pneumatic Positioner	EPR-1000
SUFFIX 2	Accessories	Model no.
X	No Specials	
A	TYPE 4 Limit Switch	APL-210N
B	TYPE 7 Limit Switch	APL-510N
C	Intrinsically Safe Limit Switch	APL-218N
Q	TYPE 4 SST Limit Switch	APL-910N
M	TYPE 7 SST Limit Switch	APL-510S
H	NEMA 4 Std. Enc.	APL-310N

NOTE: Heater and thermostat standard
(2) auxiliary switches standard
Other options available - call for details
Actuators are sized based on full differential pressure with clean water. Consult The Application Sizing Guide for assistance with sizing actuators.

SAMPLE PART #
F9RC-F1-150/3RFS-XX

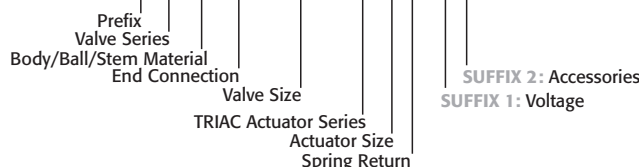

See automated part number matrix on back cover for complete part number and options.

Electric

Series F9R Unibody Direct Mount Flanged Ball Valve

- Firesafe
- Sizes 1/2" - 8"
- Available in 316SS or WCB
- ASME Class 150
- Regular Port Design
- Superior Live Loaded Packing System
- ISO 5211 Actuator Mounting Pad
- Blowout Proof Stem w/ Anti-Static Devices
- TFM™-1600 Seats Standard
- Contained Graphite
- Lockable Manual Handle
- Adjustable Packing w/o Actuator Disassembly

STANDARDS

Design	ASME B16.34 (fully conforms)
Face to Face	ASME B16.10
Flange Dimensions	ASME B16.5
Pressure Testing	API 598
Fire Testing	API 607-7th Edition
Fugitive Emissions	ISO 15848-1
	ISO FE BH - C03 - SSAO - T200°C - Class 300 - ISO 15848-1
Sulfide Stress Protection	NACE MR0175/MR0103
Mounting	ISO 5211
Marking System for Valves	MSS SP-25
Material Certification	EN 10204-3.1 MTR
Quality Assurance	ISO 9001:2015

**API 607 - 7th Edition
CERTIFIED**



**ASME Class 150 Flanged
Firesafe Tested to API 607**

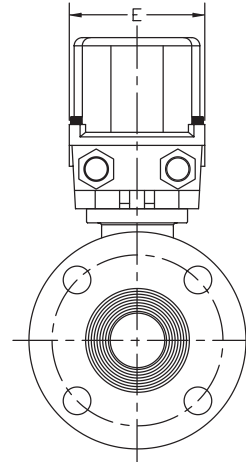
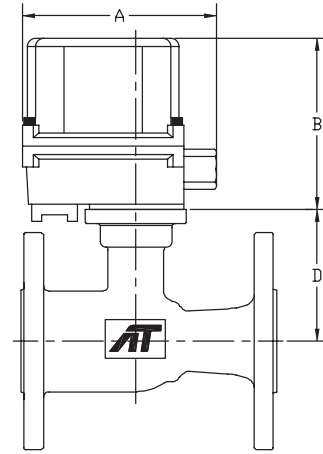

**SERIES F9R Unibody Flanged
Firesafe**

DIMENSIONS (IN)

VALVE SIZE	A	B	D	E	VALVE Cv
1/2"	5.92	5.32	1.91	4.09	8
3/4"	5.92	5.32	2.01	4.09	15
1"	5.92	5.32	2.50	4.09	44
1-1/2"	5.92	5.32	2.80	4.09	120
2"	5.92	5.32	3.05	4.09	160
2-1/2"	6.69	9.25	3.58	10.16	250
3"	9.02	10.55	4.49	13.31	350
4"	9.02	10.55	5.00	13.31	650
6"	10.20	11.42	6.42	14.49	950
8"	10.20	11.42	8.39	14.49	1875

DIMENSIONS FOR ON/OFF ACTUATORS ONLY, MODULATING NOT SHOWN 2-1/2" THRU 6" HAVE HANDWHEELS THAT ARE NOT SHOWN

ON-OFF	
SIZE	MODEL
1/2"	F9R-F1-050/WEA1-XX
3/4"	F9R-F1-075/WEA1-XX
1"	F9R-F1-100/WEA1-XX
1-1/2"	F9R-F1-150/WEA1-XX
2"	F9R-F1-200/WEA1-XX
2-1/2"	F9R-F1-250/WEB1-XX
3"	F9R-F1-300/WEC1-XX
4"	F9R-F1-400/WEC1-XX
6"	F9R-F1-600/WEE1-XX
8"	F9R-F1-800/WEE1-XX

NOTE: Heater and thermostat standard
(2) auxiliary switches standard

MODULATING	
SIZE	MODEL
1/2"	F9R-F1-050/WEA2-XX
3/4"	F9R-F1-075/WEA2-XX
1"	F9R-F1-100/WEA2-XX
1-1/2"	F9R-F1-150/WEA2-XX
2"	F9R-F1-200/WEA2-XX
2-1/2"	F9R-F1-250/WEB2-XX
3"	F9R-F1-300/WEC2-XX
4"	F9R-F1-400/WEC2-XX
6"	F9R-F1-600/WEE2-XX
8"	F9R-F1-800/WEF2-XX

OPTIONS	
Suffix 1 Voltage / Accessory	Model No.
X No Specials	
R 24VDC Electric Actuator	
S 220VAC Electric Actuator	
T Other Voltage Electric Actuator	
W 12VDC Electric Actuator	
Y 24VAC Electric Actuator	
* No voltage specified on electric assemblies denotes 120VAC	
Suffix 2 Accessories	
X No Specials	
1 HS1 High Speed Electric	
2 HS2 High Speed Electric	

Other options available - call for details.

Actuators are sized based on full differential pressure with clean water. Consult the Application Sizing Guide for assistance with sizing actuators.

SAMPLE PART # F9RC-F1-150/WEA1-XX

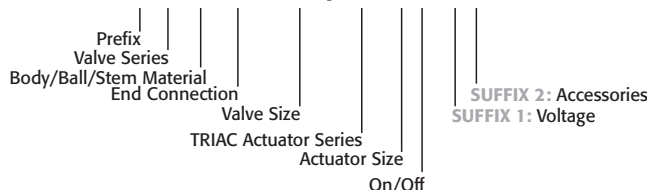

HOW TO ORDER: Manual Valves w/ Options

Series F9R

API 607 - 7th Edition
CERTIFIED

1	Prefix
F	Firesafe Tested (see valve series for details & testing)

4	End Connection
F1	150# Flanged Ends

2	Valve Series
9R	Unibody Regular Port Flanged

3	Body/Ball/Stem Material
Blank	Valve Series Standard (CF8M Stainless Steel)
C	Carbon Steel Body

HOW TO ORDER MANUAL VALVES														
1	2	3	-	4	-	5	-	6	7	8	9	-	10	11
↓	↓	↓		↓		↓		↓	↓	↓	↓		↓	↓
F	9R	C	-	F1	-	0150	-	T	X	X				

5	Valve Size
0050	1/2"
0075	3/4"
0100	1"
0150	1-1/2"
0200	2"
0250	2-1/2"
0300	3"
0400	4"
0600	6"
0800	8"

6	Seat, Lining & Trim Materials
T	TFM™-1600 Seats (Standard)
X	Reinforced TFE Seats (RTFE)
A	50% SS Powder / 50% TFM™ -1600 (STFM) Seats
S	50/50 STFE Seats

7	Special Designations
X	No Specials, Series Standard
G	Gear Operator
H	Gear Operator with Lockout Plate
S	Spring Return Handle
4	4" Lockable Stem Extension

8	Additional Specials
X	No Specials, Series Standard
O	Oxygen Cleaned
V	Vented Ball
D	Degreased & Bagged
A	Vented Ball, Degreased & Bagged
B	Vented Ball, Oxygen Cleaned

OPTIONS:

9	Additional Specials
Blank	Standard
X	Multiple Option Designation
A	17-4 PH® Stem
B	XM-19 (Nitronic 50) Stem
H	Hard Coated (HMF) Ball

10	Additional Specials
Blank	Standard
X	Multiple Option Designation
2	Markez® Z1028
4	Kalrez 4079
5	Chemraz® 505
6	Kalrez 6375
7	Perlast® G75M
9	Chemraz® 564
B	Low Temp Buna
E	EPDM
S	Silicone

11	Additional Specials
Blank	Standard
X	Multiple Option Designation
M	Marine Epoxy Coating

Chemraz® is a registered trademark of Greene, Tweed & Co.
Markez® is a registered trademark of Marco Rubber & Plastic Products Inc.
Perlast® is a registered trademark of Precision Polymer Engineering Limited.
TFM™ is a trademark of Dyneon™, a 3M Company.

Series F9R

HOW TO ORDER: Automated Valves w/ Options

API 607 - 7th Edition
CERTIFIED

1	Prefix
F	Firesafe Tested (see valve series for details & testing)

2	Valve Series
9R	Unibody Regular Port Flanged

3	Body/Ball/Stem Material
Blank	Valve Series Standard (CF8M Stainless Steel)
C	Carbon Steel Body

4	End Connection
F	150# Flanged Ends

5	Seat, Lining & Trim Materials
T	Valve Series Standard (TFM™-1600) Seats
X	Reinforced TFE Seats (RTFE)
A	50% SS Powder / 50% TFM™-1600 (STFM) Seats
S	50/50 STFE Seats

6	Valve Size	
050	1/2"	250 2-1/2"
075	3/4"	300 3"
100	1"	400 4"
150	1-1/2"	600 6"
200	2"	800 8"

7 (A) Pneumatic Actuator - 3R, 3N, 3P Series			
3RC	3R10	3RM	3R850
3RD	3R20	3RN	3R1000
3RE	3R40	3RP	3R1200
3RF	3R80	3RR	3R1750
3RG	3R130	3RS	3R2400
3RH	3R200	3RT	3R2500
3RJ	3R300	3RU	3R2700
3RK	3R500	3RV	3R3300
3RL	3R700	3RW	3R3500

3R=Standard, 3N=Electroless Nickel Plating,
3P=Teflon™ (PTFE) Coating

7 (A) Pneumatic Actuator - S2 Series			
S2C	S2-052	S2G	S2-125
S2D	S2-063	S2H	S2-140
S2E	S2-083	S2J	S2-160
S2F	S2-105	S2K	S2-210

7 (B) Pneumatic Action	
D	Double Acting (DA)
S	Spring CW (5 springs)*
O	Spring CCW (5 springs)*
4	Spring CW (4 springs)**
F	Spring CCW (4 springs)**
6	Spring CW (6 springs)
H	Spring CCW (6 springs)

*2500 & 3500 80 psig spring

**2500 & 3500 60 psig spring

7 Actuator - Electric (On-Off)			
WEX1	WE-350	WEG1	WE-5200
WEA1	WE-500	WEH1	WE-6900
WEB1	WE-690	WEJ1	WE-10500
WEC1	WE-1350	WEK1	WE-17500
WED1	WE-1700	WEL1	WE-25900
WEE1	WE-2640	WEM1	WE-53000
WEF1	WE-4400	WEN1	WE-80000

7 Actuator - Electric (Modulating)			
WEA2	WEM-500	WEH2	WEM-6900
WEB2	WEM-690	WEJ2	WEM-10500
WEC2	WEM-1350	WEK2	WEM-17500
WED2	WEM-1700	WEL2	WEM-25900
WEE2	WEM-2640	WEM2	WEM-53000
WEF2	WEM-4400	WEN2	WEM-80000
WEG2	WEM-5200		

OPTIONS:

8	Accessories/Options	Model no.
X	No Specials	
A	TYPE 4 Solenoid 120VAC	TVCS-X411-4N-A120
B	TYPE 7 Solenoid 120VAC	TVCS-X411-7N-A120
C	Intrinsically Safe Solenoid	TVIS-X411-4N-D24
D	TYPE 4 Solenoid 24VDC	TVCS-X411-4N-D24
F	TYPE 7 Solenoid 24VDC	TVCS-X411-7N-D24
Q	TYPE 4 SST Solenoid 120VAC	TVSS-X411-4N-A120
M	TYPE 7 SST Solenoid 120VAC	TVSS-X411-7N-A120
L	TYPE 4 SST Solenoid 24VDC	TVSS-X411-4N-D24
N	TYPE 7 SST Solenoid 24VDC	TVSS-X411-7N-D24
P	Pneumatic Positioner	PPR-1200
E	Electro-Pneumatic Positioner	EPR-1000
R	24VDC Electric Actuator	
S	220VAC Electric Actuator	
T	Other Voltage Electric Actuator	
W	12VDC Electric Actuator	
Y	24VAC Electric Actuator	

Blank * No voltage specified on electric assemblies denotes 120VAC

9	Accessories	Model no.
X	No Specials	
A	TYPE 4 Limit Switch	APL-210N
B	TYPE 7 Limit Switch	APL-510N
C	Intrinsically Safe Limit Switch	APL-218N
Q	TYPE 4 SST Limit Switch	APL-910N
M	TYPE 7 SST Limit Switch	APL-510S
H	NEMA 4 Std. Enc.	APL-310N
Z	180° Operation	
1	HS1 High Speed Electric	
2	HS2 High Speed Electric	

10	Special Designation
Blank	No Designation, SST Stem
A	17-4@ PH Stem
B	XM-19 (Nitronic 50) Stem
F	Viton® Seal for Pneumatic Actuators (0°F to 300°F)

17-4 PH® is a registered trademark of AK Steel Corporation.
TFM™ is a trademark of Dyneon™, a 3M Company.

AUTOMATED VALVE

SAMPLE PART #

F9RC-F1-150/3RED-XX

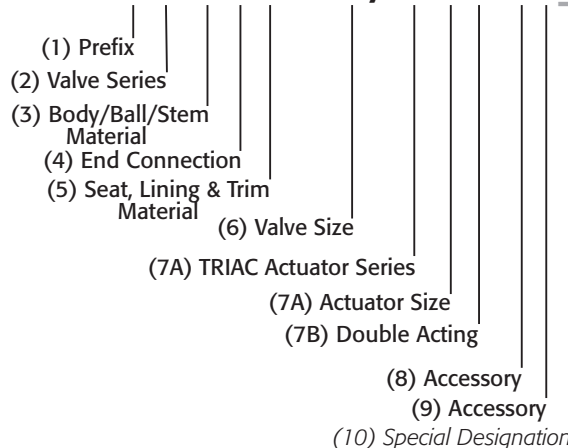

9955 International Blvd. PHONE (513) 247-5465
Cincinnati, Ohio 45246 FAX (513) 247-5462
www.atcontrols.com sales@atcontrols.com