

## Contents

1	SCOPE .....	2
2	INSTALLATION .....	2
3	VALVE OPERATION.....	3
4	DISASSEMBLY.....	4
5	ASSEMBLY .....	4
6	REPAIR KITS .....	5
7	BILL OF MATERIALS.....	6

## 1 SCOPE

### 1.1 CAUTION

- 1.1.1 For your safety, read this manual before installation or servicing.
- 1.1.2 Before installing or servicing, please ensure the line pressure has been relieved and any hazardous fluids have been drained or purged from the system.
- 1.1.3 Ensure that all Lockout and Tagout procedures for the system have been properly implemented.

### 1.2 USE

- 1.2.1 A-T Controls H78-Series Ball Valve are available in Hygienic Ferrule Ends ( $\frac{1}{2}$ " &  $\frac{3}{4}$ " Type A, 1"-4" Type B) or Extended Tube Butt Weld Ends.
- 1.2.2 Maximum results and optimum valve life can be maintained under normal service conditions and in accordance with pressure/temperature ratings and corrosion data charts.

## 2 INSTALLATION

- 2.2 A-T Controls H78-Series Ball Valves are bi-directional and can be installed with the flow in either direction. The valve can be mounted in any position so that the handle, gear, or actuator has proper clearance, allows for optimal drainage, can be easily accessed, and the open/close indicator can be viewed. If the gear is equipped with a chain wheel, the valve shall be mounted in a way so that the chain does not come in contact with the valve or pipeline.
- 2.3 Before installation of the valves, the pipe must be flushed clean of dirt, burrs, and welding residues. Failure to do so can cause the seats, sealing surfaces, and internal polish to be damaged.
- 2.4 The pipe must be free from tension and in proper alignment.
- 2.5 Before installation of the valves, check to ensure that all connections are free from defects.
- 2.6 Be sure to consult with supplier of your clamps and gaskets to be used on the hygienic ends for the proper material, pressure rating, and clamp torque for your process. Over torqueing clamps may result in damage to the ferrule end.
- 2.7 Disassembly of the valve is not necessary for tube end valves. However, caution should be taken to ensure that the heat source does not come in contact with the sealing components of the valve in excess of the sealing component temperature limitation.
- 2.8 Users should retighten the body bolts and nuts after the valves have been installed if the user has loosened or modified the valve during installation. The recommended initial set torque of the fasteners can be found in the Fastener Torque Chart.

### 3 VALVE OPERATION

#### 3.1 MANUAL

##### 3.1.1 Handle

To open the valve, pull up on the handle lock and turn the handle counter-clockwise until the handle is parallel with the pipeline and the handle has contacted the handle stop.

To close the valve, pull up on the handle lock and turn the handle clockwise until the handle is perpendicular with the pipeline and the handle has contact the handle stop.

A handle lock is incorporated into the handle. To use slide the lock into the mounting pad, in the full open or full closed position. Insert an appropriate size lock or hasp into the hole in the handle. If it can be performed safely, try to turn to ensure that the valve has been locked properly.

##### 3.1.2 Gear

To OPEN the valve; turn the hand wheel counter-clockwise. The indicator will be pointing to the open position and stop rotating when fully opened. The flow can be adjusted by stopping the indicator anywhere between open and close.

To CLOSE the valve; turn the hand wheel clockwise. The indicator will be pointing to the close position and the hand wheel will stop rotating when fully closed. The flow can be adjusted by stopping the indicator anywhere between open and close.

#### 3.2 AUTOMATED

A-T Controls H78-Series High Purity Ball Valves can be mounted with quarter turn actuators. Valves with actuators shall be checked for proper valve stem alignment. Angular or linear misalignments may result in high operational torque and unnecessary wear on the valve stem. See the actuator IOM for information on operating the actuator.

## 4 DISASSEMBLY

### !!!WARNING!!!

**CAUTION, FLUIDS CAN BE TRAPPED IN THE BODY OF THE VALVE, POSSIBLY UNDER HIGH PRESSURE. FOR YOUR SAFETY, IT IS IMPORTANT THAT PRECAUTIONS ARE TAKEN BEFORE REMOVAL OF THE VALVE FROM THE LINE OR ANY DISASSEMBLY.**

- 4.1 Remove actuator or gear if equipped.
- 4.2 Care should be taken to not damage the surface finish of the valve components.
- 4.3 Remove the ends (2/3) from the body by removing the body bolts (8) and body nuts (9).
- 4.4 Remove the seat (5) and body gasket (6) from both sides of the body (1). Once removed, with the valve in the fully closed position, the ball (4) should slide freely out of the body (1).
- 4.5 If equipped, remove the handle nut (14), handle (16), and handle stop assembly (17).
- 4.6 Using a small screw driver, bend the locking saddle (15) down so that the packing nut (14) is able to turn freely.
- 4.7 While holding the stem (7) stationary, remove the packing nut (14). Once removed, the locking saddle (15), conical spring washers (13) and packing gland (12) should be free to remove.
- 4.8 While holding the bottom of the stem (7), push the stem (7) through the inside of the valve body (1).
- 4.9 Remove the packing set (11) and thrust bearing (10).
- 4.10 Inspect all components for damage and if necessary clean or replace.

## 5 ASSEMBLY

- 5.1 Care should be taken to not damage the surface finish of the valve components.
- 5.2 Place thrust bearing (10) on the stem (7) and install it by going through the body (1). Insert V-Style packing set (11) over stem (7) with the V pointing away from the valve (see Bill of Materials for correct orientation).
- 5.3 Install the packing gland (12), the conical spring washers (13), locking saddle (15), and packing nut (13). While holding the stem (7), tighten the packing nut (14) to the torque listed in the Fastener Torque Chart. Tighten further if needed in order to be able to bend the locking saddle (15) over a flat side of the packing nut (14).
- 5.4 Ensure that the stem (7) is in the closed position with the bottom tang parallel with the flow of the valve. Insert a seat (5) and body gasket (6) in one side of the body (1). Carefully slide the ball (4) into body (1) and insert the other seat (5) and body gasket (6).
- 5.5 Assemble ends (2/3) onto body (1). Insert all body bolts (8) and nuts (9) into valve and tighten to finger tight, making sure that the ends (2/3) are flat against the body (1). Tighten all bolts (8) (on both sides for valves 2-1/2"-4") from the nut (9) side (if equipped) in a star pattern to 50% of the final torque shown in the Fastener Torque Chart. Using the handle (16) or an adjustable wrench, cycle the valve 3 times. Tighten all of the body bolts (8) to the final torque in a star pattern. Cycle the valve 3 times again. Check each body bolt torque (8) and tighten if needed a final time. It is acceptable for the torque to relax slightly over time due to relaxation of the polymer components, but the valve will still seal properly. If leakage is detected, repeat the steps for tightening the body bolts.
- 5.6 If required, assemble the handle stop assembly (17), handle (16), and handle nut (14).

Fastener Torque Chart			
Valve Size	Body Bolt Torque (in *lbs)		Packing Nut Torque (in*lbs)
	50% of Final Torque	Final Torque	
1/2"	68	135	78
3/4"	68	135	78
1"	73	145	122
1-1/2"	195	390	200
2"	283	565	200
2-1/2"	413	825	200
3"	455	910	200
4"	673	1345	217

## 6 REPAIR KITS

Repair kits are available to replace all soft goods. See Bill of Materials for components that are included in the repair kits.

7 BILL OF MATERIALS

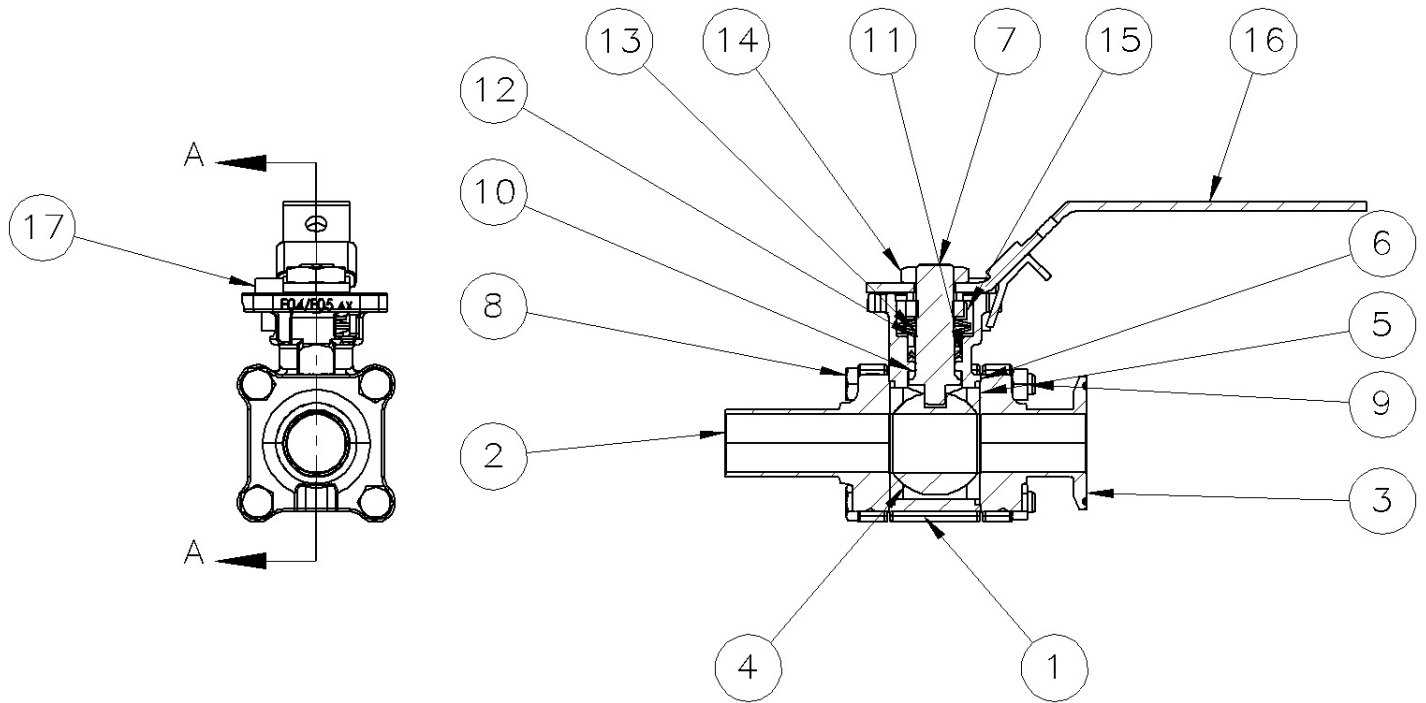

ITEM NO.	PART NAME	REPAIR KIT	QTY.	MATERIAL
1	BODY		1	ASTM A351-CF3M
2	END CONNECTION		2	ASTM A351-CF3M
3	END CONNECTION		2	ASTM A351-CF3M
4	BALL		1	ASTM A351-CF3M
5	SEAT	X	2	TFM™-1600 FDA
6	BODY GASKET	X	2	TFM™-1600 FDA
7	STEM		1	ASTM A276-316
8	BODY BOLT		#	ASTM A193 GR B8
9	BODY NUT		&	ASTM A194 GR 8
10	THRUST BEARING	X	1	TFM™-1600 FDA
11	PACKING SET	X	1	TFM™-1600 FDA
12	PACKING GLAND		1	AISI-304
13	CONICAL SPRING WASHER		2	AISI-301
14	PACKING / HANDLE NUT		2	AISI-304
15	LOCKING SADDLE		1	AISI-304
16	HANDLE WITH LOCK		1	AISI-304
17	HANDLE STOP ASSEMBLY		1	AISI-304

# FOR 1/2"-1-1/2" - 4 PCS; FOR 2"-2-1/2" - 8 PCS; FOR 3" - 12 PCS, FOR 4" -16 PCS  
& FOR 1/2"-1-1/2" - 4 PCS; FOR 2"-4" - 0 PCS

*A-T Controls product, when properly selected, is designed to perform its intended function safely during its useful life. However, the purchaser or user of A-T Controls products should be aware that A-T Controls products might be used in numerous applications under a wide variety of industrial service conditions. Although A-T Controls can provide general guidelines, it cannot provide specific data and warnings for all possible applications. The purchaser / user must therefore assume the ultimate responsibility for the proper sizing and selection, installation, operation, and maintenance of A-T Controls products. The user should read and understand the installation operation maintenance (IOM) instructions included with the product and train its employees and contractors in the safe use of A-T Controls products in connection with the specific application.*

*While the information and specifications contained in this literature are believed to be accurate, they are supplied for informative purposes only. Because A-T Controls is continually improving and upgrading its product design, the specifications, dimensions and information contained in this literature are subject to change without notice. Should any question arise concerning these specifications, the purchaser/user should contact A-T Controls.*

For product specifications go to <https://a-tcontrols.com/Downloads/>

A-T Controls, Inc. • 9955 International Boulevard, Cincinnati, OH 45246 • Phone: (513) 530-5175 • Fax: (513) 247-5462 • [www.atcontrols.com](http://www.atcontrols.com)