



Division of A-T Controls, Inc.

THD Series



Heavy Duty Actuators

**Pneumatic Actuators
for Quarter-Turn Valves
and Dampers**

Torques to 1,600,000 In-lbs

Double Acting and Spring Return

Symmetric and Canted Yoke Design

See www.atcontrols.com for
Canted Yoke product specifications



The Triac heavy duty scotch yoke actuator product line offers a broad range of torques to 1,600,000 in-lbs. The THD series is designed to operate ball, butterfly, plug valves, dampers or any device that requires a quarter-turn movement for on-off or throttling service.

Our standard offering is the symmetrical design yoke that delivers maximum torque at both ends of the 90° cycle. The square slide bearing with guide bar provides high cycle life and smooth stroke while minimizing wear points. We also offer a canted yoke design which is ideal for butterfly valves in sizes C11 and larger. See our website for the canted yoke product specifications.

As with all Triac actuators, our THD series is accompanied by a complete line of accessories, including jackscrew & hydraulic overrides, limit switches, solenoids and positioners. A-T Controls also offers complete mounting hardware to integrate our actuators with any quarter-turn valve, damper or louver.

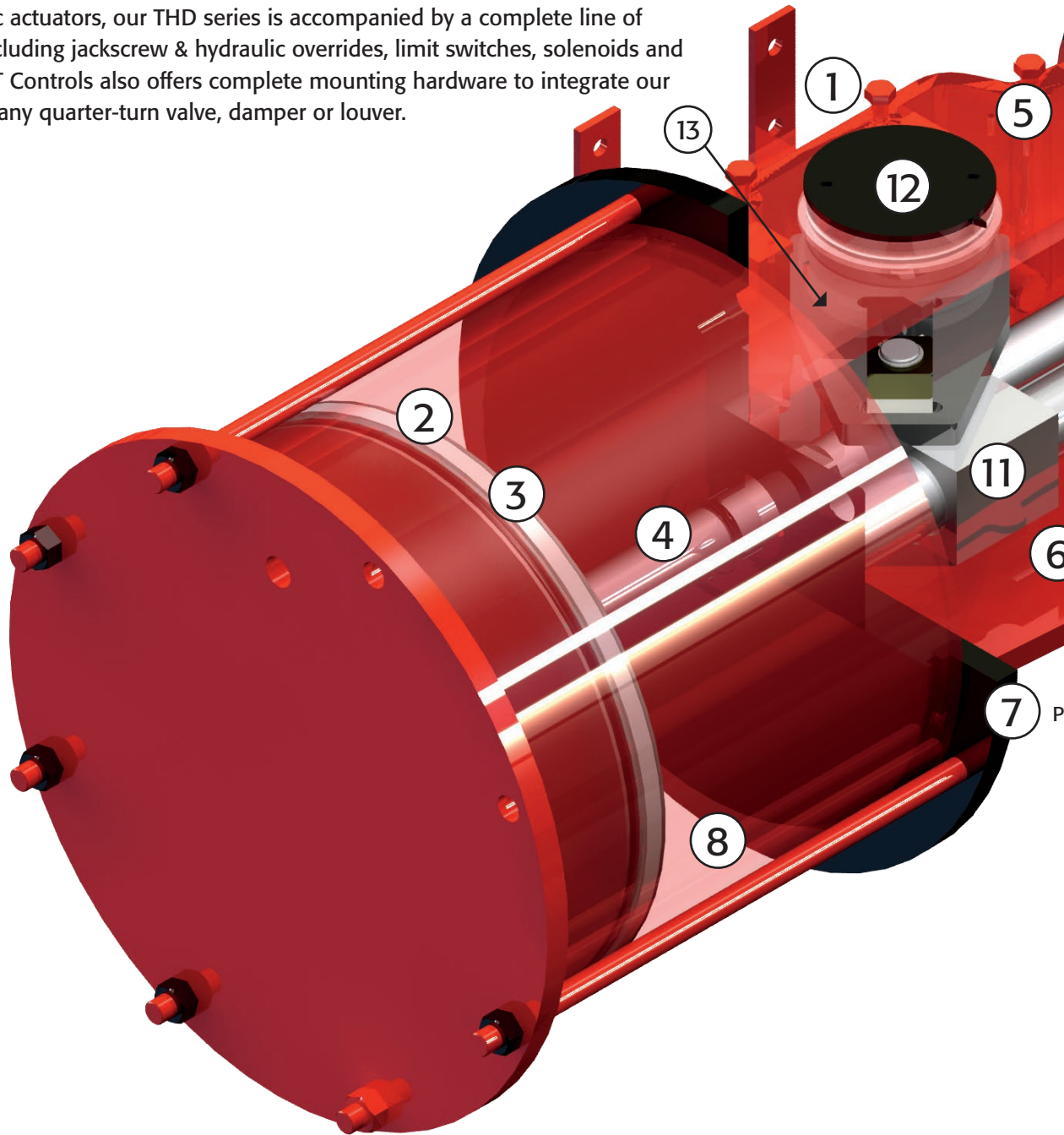

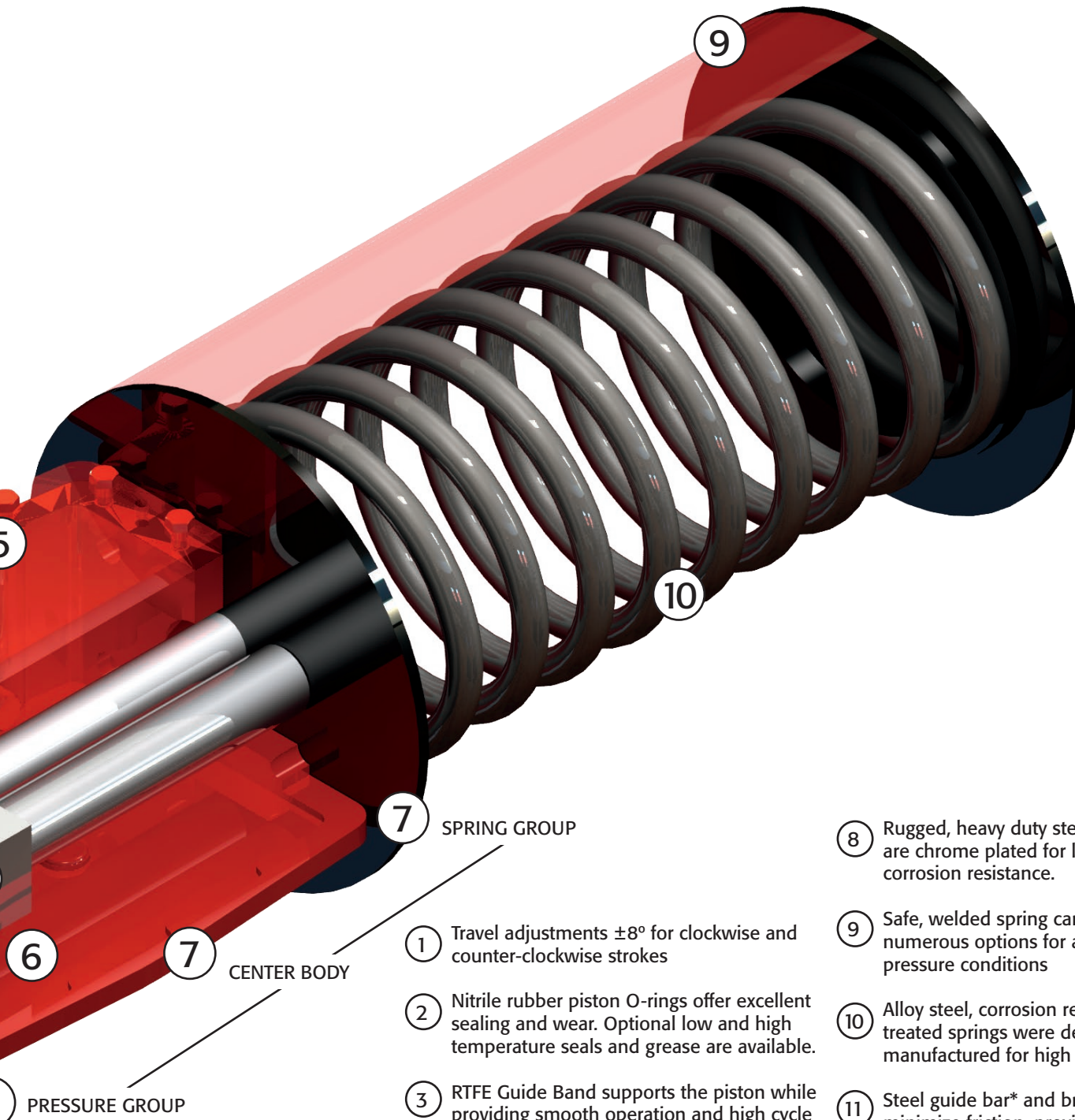

PRESSURE GROUP

CENTER BODY

SPRING GROUP

- ① Travel adjustments $\pm 8^\circ$ for clockwise and counter-clockwise strokes
- ② Nitrile rubber piston O-rings offer excellent sealing and wear. Optional low and high temperature seals and grease are available.
- ③ RTFE Guide Band supports the piston while providing smooth operation and high cycle life.
- ④ Extra large, strong piston rod for high cycle life and torque transmission
- ⑤ NAMUR accessory mounting pads permit mounting standardization of limit switches, positioners, etc.
- ⑥ Ductile iron center body
- ⑦ Modular design allows for installation of power groups and spring cartridges so that actuators may be set up for different air pressures, and for Fail Clockwise or Fail Counter-clockwise.
- ⑧ Rugged, heavy duty steel pressure cylinders are chrome plated for long wear and corrosion resistance.
- ⑨ Safe, welded spring cartridges with numerous options for a broad range of air pressure conditions
- ⑩ Alloy steel, corrosion resistant and heat treated springs were designed and manufactured for high cycle life.
- ⑪ Steel guide bar* and bronze slide bearings minimize friction, providing high cycle life.
*N/A for the S09 pressure group
- ⑫ Visual position indicator
- ⑬ Symmetric & Canted Yoke designs available

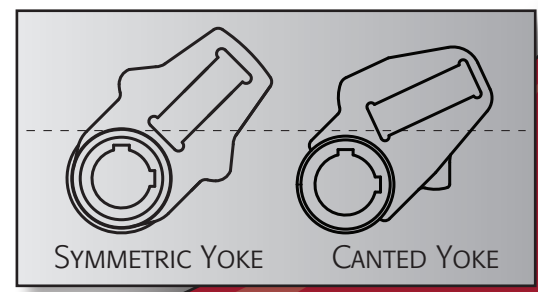

HEAVY DUTY SYMMETRICAL YOKE DOUBLE ACTING TORQUE CHART

MODEL NUMBER	TORQUE OUT PUT IN-LBS								MOP*	MAWP**	SWEPT VOLUME CU. IN. ***	WEIGHT LBS
	40 PSI		60 PSI		80 PSI		100 PSI					
	Start	Min	Start	Min	Start	Min	Start	Min				
S09DA200	9,662	5,176	14,493	7,764	19,325	10,352	24,156	12,941	100	200	442	280
S09DA280	18,938	10,145	28,407	15,218	37,876	20,291	47,345	25,363	100	150	866	348
S09DA335	27,109	14,523	40,663	21,784	54,217	29,045	67,772	36,306	100	105	1,239	375
S09DA385	35,805	19,181	53,707	28,772	71,609	38,362			80	80	1,637	437
S11DA280	24,965	13,227	37,448	19,840	49,930	26,453	62,413	33,066	100	150	1,058	525
S11DA335	35,736	18,933	53,604	28,400	71,472	37,866	89,340	47,333	100	130	1,514	582
S11DA385	47,200	25,006	70,799	37,510	94,399	50,013	117,999	62,516	100	105	2,000	639
S11DA435	60,255	31,923	90,383	47,885	120,511	63,847			80	80	2,554	694
S13DA385	55,781	29,553	83,672	44,330	111,563	59,106	139,454	73,883	100	150	2,364	1,058
S13DA435	71,211	37,728	106,816	56,592	142,422	75,455	178,027	94,319	100	150	3,018	1,135
S13DA485	88,522	46,899	132,783	70,349	177,044	93,798	221,305	117,248	100	125	3,752	1,257
S13DA535	107,715	57,068	161,572	85,601	215,430	114,135	269,287	142,669	100	120	4,565	1,312
S13DA585	128,789	68,233	193,184	102,349	257,579	136,466	321,973	170,582	100	100	5,458	1,429
S13DA635	151,745	80,395	227,618	120,593	303,491	160,790			80	85	6,431	1,532
S16DA485	108,950	57,722	163,425	86,583	217,900	115,444	272,376	144,305	100	125	4,617	1,951
S16DA535	132,572	70,237	198,858	105,355	265,144	140,474	331,430	175,592	100	125	5,618	2,094
S16DA585	158,510	83,979	237,765	125,968	317,020	167,958	396,275	209,947	100	115	6,718	2,244
S16DA635	186,764	98,948	280,145	148,422	373,527	197,895	466,909	247,369	100	100	7,915	2,370
S16DA685	217,333	115,144	326,000	172,715	434,666	230,287			80	85	9,211	2,491
S20DA585	198,137	104,974	297,206	157,460	396,275	209,947	495,343	262,434	100	125	8,397	2,931
S20DA635	233,454	123,685	350,182	185,527	466,909	247,369	583,636	309,212	100	125	9,894	3,153
S20DA685	271,666	143,929	407,500	215,894	543,333	287,859	679,166	359,823	100	115	11,513	3,289
S20DA735	312,773	165,708	469,160	248,562	625,546	331,416	781,933	414,270	100	100	13,255	3,439
S20DA785	356,775	189,020	535,162	283,530	713,549	378,040			80	90	15,120	3,627
S20DA835	403,671	213,866	605,507	320,799	807,342	427,732			80	80	17,108	3,803
S27DA735	422,244	223,706	633,366	335,558	844,487	447,411	1,055,609	559,264	100	125	17,895	
S27DA785	481,646	255,177	722,469	382,765	963,292	510,354	1,204,115	637,942	100	125	20,412	
S27DA835	544,956	288,719	817,434	433,078	1,089,912	577,438	1,362,390	721,797	100	125	23,095	
S27DA885	612,174	324,331	918,261	486,497	1,224,348	648,662	1,530,436	810,828	100	115	25,944	
S27DA935	683,300	362,014	1,024,951	543,021	1,366,601	724,028	1,708,251	905,035	100	100	28,958	
S27DA985	758,335	401,767	1,137,502	602,651	1,516,669	803,535			80	90	32,138	
S27DA1020	813,184	430,827	1,219,776	646,240	1,626,368	861,653			80	85	34,463	

* Maximum operating pressure (MOP) is the pressure required to produce the maximum rated torque of the actuator.

** Maximum Allowable Working Pressure (MAWP) is the maximum static pressure that may be applied to a fully stroked actuator against the travels stops.

*** Swept Volume is the maximum volume including the cavity required for calculating consumption per 90 deg stroke.

NOTE: Heavy Duty Canted Yoke Torque Chart may be found on our website www.atcontrols.com.

HEAVY DUTY SYMMETRICAL YOKE SPRING RETURN TORQUE CHART

MODEL	SPRING CODE		TORQUE OUTPUT IN-LBS					MOP*	MAWP**	SWEPT VOLUME CU. IN. ***	WEIGHT LBS
			SPRING	40 PSI	60 PSI	80 PSI	100 PSI				
S09SR200	AA	START	6,307	5,991	10,823	15,654	20,485	100	200	442	390
		MIN	2,368	2,289	4,780	7,271	9,761				
		END	3,671	3,355	8,186	13,017	17,848				
	AB	START	9,971		8,987	13,818	18,649	100	200	442	401
		MIN	3,645		3,279	5,770	8,261				
		END	5,506		4,523	9,354	14,185				
	AC	START	12,615		7,152	11,983	16,814	100	200	442	406
		MIN	4,737		2,088	4,579	7,069				
		END	7,342		1,879	6,710	11,541				
AD	START	15,681			10,147	14,978	100	200	442	434	
	MIN	5,905			3,259	5,750					
	END	9,177			3,644	8,475					
AE	START	17,686			9,021	13,852	100	200	442	419	
	MIN	6,644			2,412	4,903					
	END	10,303			1,639	6,470					
AF	START	18,704				13,361	100	200	442	419	
	MIN	6,993				4,490					
	END	10,794				5,452					
S09SR280	AB	START	9,971	13,432	22,901	32,370	41,839	100	150	866	470
		MIN	3,645	4,612	10,453	15,334	20,216				
		END	5,506	5,803	18,436	27,905	37,374				
	AC	START	12,615	11,596	21,065	30,534	40,003	100	150	866	474
		MIN	4,737	4,379	9,261	14,143	19,025				
		END	7,342	6,323	15,792	25,261	34,730				
	AD	START	15,681	9,761	19,230	28,699	38,168	100	150	866	503
		MIN	5,905	3,060	7,942	12,824	17,705				
		END	9,177	3,257	12,726	22,195	31,664				
	AE	START	17,686	8,635	18,104	27,573	37,042	100	150	866	487
		MIN	6,644	2,213	7,095	11,977	16,858				
		END	10,303	1,252	10,721	20,190	29,659				
	AF	START	18,704		17,613	27,082	36,551	100	150	866	487
		MIN	6,993		6,682	11,563	16,445				
		END	10,794		9,703	19,172	28,641				
	AG	START	24,585			23,485	32,954	100	150	866	496
		MIN	9,259			9,016	13,898				
		END	14,391			13,291	22,760				
	AH	START	30,643			19,889	29,358	100	150	866	525
		MIN	11,557			6,416	11,298				
		END	17,987			7,233	16,702				
	AJ	START	35,015				26,744	100	150	866	525
		MIN	13,223				9,417				
		END	20,601				12,330				
	AK	START	43,860				21,589	100	150	866	538
		MIN	16,546				5,641				
		END	25,756				3,485				

* Maximum operating pressure (MOP) is the pressure required to produce the maximum rated torque of the actuator.

** Maximum Allowable Working Pressure (MAWP) is the maximum static pressure that may be applied to a fully stroked actuator against the travels stops.

*** Swept Volume is the maximum volume including the cavity required for calculating consumption per 90 deg stroke.

NOTE: Heavy Duty Canted Yoke Torque Chart may be found on our website www.atcontrols.com.

HEAVY DUTY SYMMETRICAL YOKE SPRING RETURN TORQUE CHART (cont.)

MODEL	SPRING CODE		TORQUE OUTPUT IN-LBS					MOP*	MAWP**	SWEPT VOLUME CU. IN. ***	WEIGHT LBS
			SPRING	40 PSI	60 PSI	80 PSI	100 PSI				
S09SR335	AE	START	17,686	16,805	30,360	43,914	57,468	100	125	1,239	514
		MIN	6,644	6,425	13,413	20,401	27,389				
		END	10,303	9,423	22,977	36,532	50,086				
	AF	START	18,704	16,314	29,869	43,423	56,977	100	125	1,239	522
		MIN	6,993	6,012	13,000	19,988	26,976				
		END	10,794	8,405	21,959	35,513	49,068				
	AG	START	24,585		26,272	39,827	53,381	100	125	1,239	551
		MIN	9,259		10,453	17,441	24,429				
		END	14,391		16,078	29,632	43,186				
AH	START	30,643		22,676	36,230	49,784	100	125	1,239	551	
	MIN	11,557		7,853	14,841	21,829					
	END	17,987		10,020	23,575	37,129					
AJ	START	35,015		20,062	33,616	47,170	100	125	1,239	551	
	MIN	13,223		5,972	12,960	19,948					
	END	20,601		5,648	19,203	32,757					
AK	START	43,860			28,462	42,016	100	125	1,239	564	
	MIN	16,546			9,184	16,172					
	END	25,756			10,357	23,912					
AL	START	46,197			27,003	40,558	100	125	1,239	564	
	MIN	17,456			8,165	15,153					
	END	27,214			8,020	21,575					
AM	START	58,623				33,757	100	125	1,239	578	
	MIN	21,978				9,941					
	END	34,015				9,149					
S09SR385	AG	START	24,585	21,414	39,316	57,219	75,121	80	100	1,637	564
		MIN	9,259	7,949	17,178	26,408	35,637				
		END	14,391	11,219	29,122	47,024	64,926				
	AH	START	30,643	17,817	35,720	53,622	71,524	100	100	1,637	613
		MIN	11,557	5,348	14,578	23,807	33,037				
		END	17,987	5,162	23,064	40,967	58,869				
	AJ	START	35,015		33,106	51,008	68,910	100	105	1,637	613
		MIN	13,223		12,697	21,926	31,156				
		END	20,601		18,692	36,595	54,497				
AK	START	43,860		27,951	45,854	63,756	100	105	1,637	626	
	MIN	16,546		8,921	18,150	27,380					
	END	25,756		9,847	27,750	45,652					
AL	START	46,197		26,493	44,395	62,298	100	110	1,637	626	
	MIN	17,456		7,902	17,132	26,361					
	END	27,214		7,510	25,412	43,315					
AM	START	58,623			37,594	55,497	100	115	1,637	639	
	MIN	21,978			11,920	21,149					
	END	34,015			12,987	30,889					

* Maximum operating pressure (MOP) is the pressure required to produce the maximum rated torque of the actuator.
 ** Maximum Allowable Working Pressure (MAWP) is the maximum static pressure that may be applied to a fully stroked actuator against the travels stops.
 *** Swept Volume is the maximum volume including the cavity required for calculating consumption per 90 deg stroke.

NOTE: Heavy Duty Canted Yoke Torque Chart may be found on our website www.atcontrols.com.

HEAVY DUTY SYMMETRICAL YOKE SPRING RETURN TORQUE CHART

MODEL	SPRING CODE		TORQUE OUTPUT IN-LBS					MOP*	MAWP**	SWEPT VOLUME CU. IN. ***	WEIGHT LBS
			SPRING	40 PSI	60 PSI	80 PSI	100 PSI				
S11SR280	BA	START	16,279	15,483	27,966	40,448	52,931	100	150	1,058	827
		MIN	6,318	6,117	12,766	19,414	26,063				
		END	9,482	8,686	21,169	33,651	46,134				
	BB	START	23,205	11,389	23,872	36,355	48,837	100	150	1,058	838
		MIN	9,026	3,050	9,698	16,347	22,995				
		END	13,576	1,761	14,243	26,726	39,208				
	BC	START	30,681		19,510	31,993	44,475	100	150	1,058	884
		MIN	11,930		6,399	13,048	19,696				
		END	17,937		6,766	19,249	31,731				
BD	START	35,097		17,078	29,560	42,043	100	150	1,058	884	
	MIN	13,596		4,483	11,131	17,779					
	END	20,370		2,351	14,834	27,316					
BE	START	39,320			27,036	39,518	100	150	1,058	983	
	MIN	15,257			9,254	15,903					
	END	22,894			10,610	23,093					
BF	START	47,010			23,027	35,510	100	150	1,058	983	
	MIN	18,078			5,966	12,614					
	END	26,903			2,920	15,403					
BG	START	61,073				26,544	100	150	1,058	999	
	MIN	23,804				6,242					
	END	35,868				1,340					
S11SR335	BB	START	23,205	22,160	40,028	57,896	75,765	100	150	1,514	895
		MIN	9,026	8,787	18,303	27,820	37,337				
		END	13,576	12,532	30,400	48,268	66,136				
	BC	START	30,681	17,799	35,667	53,535	71,403	100	150	1,514	941
		MIN	11,930	5,488	15,004	24,521	34,038				
		END	17,937	5,055	22,923	40,791	58,659				
	BD	START	35,097		33,234	51,102	68,970	100	150	1,514	941
		MIN	13,596		13,088	22,605	32,121				
		END	20,370		18,508	36,376	54,244				
	BE	START	39,320		30,710	48,578	66,446	100	150	1,514	1,041
		MIN	15,257		11,211	20,728	30,245				
		END	22,894		14,284	32,152	50,020				
	BF	START	47,010		26,701	44,569	62,437	100	150	1,514	1,041
		MIN	18,078		7,923	17,439	26,956				
		END	26,903		6,594	24,462	42,330				
	BG	START	61,073			35,604	53,472	100	150	1,514	1,056
		MIN	23,804			11,067	20,584				
		END	35,868			10,399	28,267				
BH	START	77,797				43,545	100	150	1,514	1,074	
	MIN	30,359				13,168					
	END	45,795				11,543					

* Maximum operating pressure (MOP) is the pressure required to produce the maximum rated torque of the actuator.

** Maximum Allowable Working Pressure (MAWP) is the maximum static pressure that may be applied to a fully stroked actuator against the travels stops.

*** Swept Volume is the maximum volume including the cavity required for calculating consumption per 90 deg stroke.

NOTE: Heavy Duty Canted Yoke Torque Chart may be found on our website www.atcontrols.com.

HEAVY DUTY SYMMETRICAL YOKE SPRING RETURN TORQUE CHART (cont.)

MODEL	SPRING CODE		TORQUE OUTPUT IN-LBS				MOP*	MAWP**	SWEPT VOLUME CU. IN. ***	WEIGHT LBS	
			SPRING	40 PSI	60 PSI	80 PSI					100 PSI
S11SR385	BC	START	30,681	29,262	52,862	76,462	100,062	100	115	2,000	999
		MIN	11,930	11,593	24,163	36,733	49,302				
		END	17,937	16,518	40,118	63,718	87,318				
	BD	START	35,097	26,830	50,429	74,029	97,629	100	120	2,000	999
		MIN	13,596	9,677	22,246	34,816	47,386				
		END	20,370	12,103	35,703	59,303	82,903				
	BE	START	39,320	24,305	47,905	71,505	95,105	100	120	2,000	1,098
		MIN	15,257	7,800	20,370	32,939	45,509				
		END	22,894	7,880	31,480	55,079	78,679				
BF	START	47,010		43,897	67,496	91,096	100	125	2,000	1,098	
	MIN	18,078		17,081	29,651	42,221					
	END	26,903		23,789	47,389	70,989					
BG	START	61,073		34,931	58,531	82,131	100	125	2,000	1,113	
	MIN	23,804		10,709	23,279	35,848					
	END	35,868		9,726	33,326	56,926					
BH	START	77,797			48,604	72,204	100	125	2,000	1,131	
	MIN	30,359			15,862	28,432					
	END	45,795			16,603	40,202					
BJ	START	97,460				60,754	100	125	2,000	1,168	
	MIN	37,989				19,761					
	END	57,246				20,539					
S11SR435	BE	START	39,320	37,361	67,489	97,616	127,744	80	90	2,554	1,153
		MIN	15,257	14,754	30,800	46,847	62,893				
		END	22,894	20,935	51,063	81,191	111,319				
	BF	START	47,010	33,352	63,480	93,608	123,736	80	95	2,554	1,153
		MIN	18,078	11,465	27,512	43,558	59,605				
		END	26,903	13,245	43,373	73,501	103,628				
	BG	START	61,073		54,515	84,642	114,770	100	105	2,554	1,168
		MIN	23,804		21,140	37,186	53,233				
		END	35,868		29,310	59,438	89,565				
	BH	START	77,797		44,588	74,716	104,843	100	110	2,554	1,186
		MIN	30,359		13,723	29,770	45,816				
		END	45,795		12,586	42,714	72,842				
	BJ	START	97,460			63,265	93,393	100	120	2,554	1,224
		MIN	37,989			21,098	37,145				
		END	57,246			23,051	53,178				

* Maximum operating pressure (MOP) is the pressure required to produce the maximum rated torque of the actuator.
 ** Maximum Allowable Working Pressure (MAWP) is the maximum static pressure that may be applied to a fully stroked actuator against the travels stops.
 *** Swept Volume is the maximum volume including the cavity required for calculating consumption per 90 deg stroke.

HEAVY DUTY SYMMETRICAL YOKE SPRING RETURN TORQUE CHART

MODEL	SPRING CODE		TORQUE OUTPUT IN-LBS				MOP*	MAWP**	SWEPT VOLUME CU. IN. ***	WEIGHT LBS	
			SPRING	40 PSI	60 PSI	80 PSI					100 PSI
S13SR385	CA	START	36,230	34,583	62,473	90,364	118,255	100	150	2,634	1,517
		MIN	14,094	13,711	28,566	43,421	58,276				
		END	21,199	19,552	47,443	75,333	103,224				
	CB	START	56,318		51,878	79,768	107,659	100	150	2,634	1,539
		MIN	21,507		19,949	34,804	49,659				
		END	31,794		27,354	55,245	83,135				
	CC	START	70,651		43,083	70,974	98,864	100	150	2,634	1,801
		MIN	27,224		13,529	28,385	43,240				
		END	40,589		13,022	40,912	68,803				
CD	START	86,050			61,112	89,003	100	150	2,634	1,781	
	MIN	33,509			21,397	36,253					
	END	50,451			25,513	53,404					
CE	START	105,703				78,052	100	150	2,634	1,819	
	MIN	40,964				27,694					
	END	61,402				33,751					
CF	START	125,616				66,050	100	150	2,634	1,832	
	MIN	48,832				18,823					
	END	73,404				13,838					
S13SR435	CB	START	56,318	39,417	75,022	110,627	146,233	100	130	3,018	1,616
		MIN	21,507	13,311	32,276	51,240	70,204				
		END	31,794	14,893	50,498	86,104	121,709				
	CC	START	70,651	30,622	66,227	101,833	137,438	100	130	3,018	1,878
		MIN	27,224	6,892	25,857	44,821	63,785				
		END	40,589	560	36,166	71,771	107,377				
	CD	START	86,050		56,366	91,971	127,577	100	130	3,018	1,858
		MIN	33,509		18,869	37,834	56,798				
		END	50,451		20,767	56,372	91,978				
CE	START	105,703			81,020	116,626	100	130	3,018	1,896	
	MIN	40,964			29,275	48,239					
	END	61,402			36,719	72,325					
CF	START	125,616			69,018	104,624	100	130	3,018	1,909	
	MIN	48,832			20,404	39,368					
	END	73,404			16,806	52,412					
CG	START	147,409				91,532	100	130	3,018	1,929	
	MIN	57,428				29,669					
	END	86,496				30,618					
S13SR485	CC	START	70,651	47,933	92,194	136,455	180,716	100	125	3,752	2,000
		MIN	27,224	16,113	39,687	63,261	86,835				
		END	40,589	17,871	62,133	106,394	150,655				
	CD	START	86,050	38,071	82,333	126,594	170,855	100	125	3,752	1,980
		MIN	33,509	9,126	32,700	56,274	79,848				
		END	50,451	2,473	46,734	90,995	135,256				
	CE	START	105,703		71,381	115,643	159,904	100	125	3,752	2,017
		MIN	40,964		24,141	47,715	71,289				
		END	61,402		27,081	71,342	115,603				
CF	START	125,616			103,640	147,901	100	125	3,752	2,030	
	MIN	48,832			38,844	62,419					
	END	73,404			51,429	95,690					
CG	START	147,409				134,810	100	125	3,752	2,050	
	MIN	57,428				52,720					
	END	86,496				73,896					
CH	START	196,013				105,983	100	125	3,752	2,055	
	MIN	76,469				31,171					
	END	115,322				25,292					

* Maximum operating pressure (MOP) is the pressure required to produce the maximum rated torque of the actuator.

** Maximum Allowable Working Pressure (MAWP) is the maximum static pressure that may be applied to a fully stroked actuator against the travels stops.

*** Swept Volume is the maximum volume including the cavity required for calculating consumption per 90 deg stroke.

NOTE: Heavy Duty Canted Yoke Torque Chart may be found on our website www.atcontrols.com.

HEAVY DUTY SYMMETRICAL YOKE SPRING RETURN TORQUE CHART (cont.)

MODEL	SPRING CODE		TORQUE OUTPUT IN-LBS					MOP*	MAWP**	SWEPT VOLUME CU. IN. ***	WEIGHT LBS
			SPRING	40 PSI	60 PSI	80 PSI	100 PSI				
S13SR535	CD	START	86,050	57,264	111,122	164,979	218,837	100	125	4,565	2,035
		MIN	33,509	19,348	48,033	76,719	105,404				
		END	50,451	21,665	75,523	129,380	183,238				
	CE	START	105,703		100,171	154,028	207,886	100	125	4,565	2,072
		MIN	40,964		39,475	68,160	96,845				
		END	61,402		55,870	109,727	163,585				
	CF	START	125,616		88,169	142,026	195,883	100	125	4,565	2,086
		MIN	48,832		30,604	59,289	87,975				
		END	73,404		35,957	89,814	143,672				
	CG	START	147,409			128,934	182,792	100	125	4,565	2,105
		MIN	57,428			49,590	78,276				
		END	86,496			68,020	121,878				
	CH	START	196,013				153,965	100	125	4,565	2,110
		MIN	76,469				56,727				
		END	115,322				73,274				
	CJ	START	245,416				125,131	100	125	4,565	2,138
		MIN	95,662				34,926				
		END	144,157				23,871				
S13SR585	CE	START	105,703	67,388	131,782	196,177	260,572	100	120	5,458	2,189
		MIN	40,964	22,014	56,312	90,609	124,907				
		END	61,402	23,087	87,481	151,876	216,271				
	CF	START	125,616		119,780	184,175	248,570	100	120	5,458	2,202
		MIN	48,832		47,441	81,739	116,036				
		END	73,404		67,568	131,963	196,358				
	CG	START	147,409		106,688	171,083	235,478	100	120	5,458	2,222
		MIN	57,428		37,742	72,040	106,337				
		END	86,496		45,775	110,169	174,564				
	CH	START	196,013			142,256	206,651	100	120	5,458	2,227
		MIN	76,469			50,490	84,788				
		END	115,322			61,565	125,960				
	CJ	START	245,416			113,422	177,817	100	120	5,458	2,255
		MIN	95,662			28,689	62,987				
		END	144,157			12,163	76,557				
S13SR635	CF	START	125,616	78,342	154,214	230,087	305,960	100	105	6,431	2,306
		MIN	48,832	25,370	65,781	106,192	146,603				
		END	73,404	26,130	102,003	177,875	253,748				
	CG	START	147,409		141,123	216,995	292,868	100	105	6,431	2,326
		MIN	57,428		56,082	96,493	136,904				
		END	86,496		80,209	156,081	231,954				
	CH	START	196,013			188,169	264,041	100	110	6,431	2,330
		MIN	76,469			74,944	115,355				
		END	115,322			107,478	183,350				
	CJ	START	227,538			147,727	218,073	100	125	6,431	2,359
		MIN	85,851			47,692	83,959				
		END	133,655			53,844	124,190				

* Maximum operating pressure (MOP) is the pressure required to produce the maximum rated torque of the actuator.
 ** Maximum Allowable Working Pressure (MAWP) is the maximum static pressure that may be applied to a fully stroked actuator against the travels stops.
 *** Swept Volume is the maximum volume including the cavity required for calculating consumption per 90 deg stroke.

NOTE: Heavy Duty Canted Yoke Torque Chart may be found on our website www.atcontrols.com.

HEAVY DUTY SYMMETRICAL YOKE SPRING RETURN TORQUE CHART

MODEL	SPRING CODE		TORQUE OUTPUT IN-LBS					MOP*	MAWP**	SWEPT VOLUME CU. IN. ***	WEIGHT LBS
			SPRING	40 PSI	60 PSI	80 PSI	100 PSI				
S16SR485	DA	START	71,354	67,555	122,030	176,505	230,980	100	125	4,617	2,725
		MIN	27,634	26,596	55,610	84,625	113,639				
		END	41,395	37,597	92,072	146,547	201,022				
	DB	START	106,431		101,332	155,807	210,283	100	125	4,617	2,738
		MIN	41,340		40,082	69,096	98,110				
		END	62,093		56,994	111,469	165,944				
	DC	START	129,487		87,864	142,339	196,814	100	125	4,617	2,767
		MIN	50,301		29,905	58,919	87,934				
		END	75,562		33,939	88,414	142,889				
DD	START	155,652			127,557	182,033	100	125	4,617	2,780	
	MIN	60,297			47,480	76,495					
	END	90,343			62,248	116,723					
DE	START	180,743			111,454	165,929	100	125	4,617	2,791	
	MIN	70,549			36,088	65,102					
	END	106,447			37,157	91,632					
DF	START	210,751			94,028	148,503	100	125	4,617	2,800	
	MIN	82,177			22,865	51,879					
	END	123,872			7,149	61,624					
S16SR535	DB	START	106,431	70,479	136,765	203,051	269,337	100	125	5,618	2,881
		MIN	41,340	23,649	58,954	94,259	129,564				
		END	62,093	26,141	92,427	158,713	224,999				
	DC	START	129,487		123,296	189,583	255,869	100	125	5,618	2,910
		MIN	50,301		48,777	84,082	119,387				
		END	75,562		69,371	135,657	201,944				
	DD	START	155,652		108,515	174,801	241,087	100	125	5,618	2,923
		MIN	60,297		37,338	72,643	107,948				
		END	90,343		43,206	109,492	175,778				
DE	START	180,743		92,412	158,698	224,984	100	125	5,618	2,934	
	MIN	70,549		25,945	61,251	96,556					
	END	106,447		18,115	84,401	150,687					
DF	START	210,751			141,272	207,558	100	125	5,618	2,943	
	MIN	82,177			48,028	83,333					
	END	123,872			54,393	120,679					
DG	START	280,812				166,258	100	125	5,618	2,956	
	MIN	109,537				52,326					
	END	165,172				50,619					
S16SR585	DC	START	129,487	82,948	162,203	241,458	320,713	100	125	6,718	3,060
		MIN	50,301	27,287	69,499	111,712	153,924				
		END	75,562	29,023	108,278	187,533	266,788				
	DD	START	155,652		147,422	226,677	305,932	100	125	6,718	3,073
		MIN	60,297		58,060	100,273	142,485				
		END	90,343		82,113	161,368	240,622				
	DE	START	180,743		131,318	210,573	289,828	100	125	6,718	3,084
		MIN	70,549		46,668	88,880	131,093				
		END	106,447		57,022	136,277	215,531				
DF	START	210,751		113,893	193,148	272,403	100	125	6,718	3,093	
	MIN	82,177		33,445	75,657	117,870					
	END	123,872		27,013	106,268	185,523					
DG	START	280,812			151,847	231,102	100	125	6,718	3,106	
	MIN	109,537			44,651	86,863					
	END	165,172			36,208	115,463					
DH	START	353,858				189,812	100	125	6,718	3,122	
	MIN	137,451				54,923					
	END	206,463				42,416					

* Maximum operating pressure (MOP) is the pressure required to produce the maximum rated torque of the actuator.

** Maximum Allowable Working Pressure (MAWP) is the maximum static pressure that may be applied to a fully stroked actuator against the travels stops.

*** Swept Volume is the maximum volume including the cavity required for calculating consumption per 90 deg stroke.

NOTE: Heavy Duty Canted Yoke Torque Chart may be found on our website www.atcontrols.com.

HEAVY DUTY SYMMETRICAL YOKE SPRING RETURN TORQUE CHART (cont.)

MODEL	SPRING CODE		TORQUE OUTPUT IN-LBS				MOP*	MAWP**	SWEPT VOLUME CU. IN. ***	WEIGHT LBS	
			SPRING	40 PSI	60 PSI	80 PSI					100 PSI
S16SR635	DD	START	155,652	96,421	189,802	283,184	376,566	100	120	7,915	3,199
		MIN	60,297	30,896	80,633	130,370	180,106				
		END	90,343	31,111	124,493	217,875	311,257				
	DE	START	180,743		173,699	267,081	360,462	100	120	7,915	3,210
		MIN	70,549		69,240	118,977	168,714				
		END	106,447		99,402	192,784	286,166				
	DF	START	210,751		156,273	249,655	343,037	100	120	7,915	3,219
		MIN	82,177		56,017	105,754	155,491				
		END	123,872		69,394	162,776	256,157				
	DG	START	280,812			208,355	301,737	100	120	7,915	3,232
		MIN	109,537			74,747	124,484				
		END	165,172			92,715	186,097				
	DH	START	353,858			167,064	260,446	100	120	7,915	3,247
		MIN	137,451			42,807	92,544				
		END	206,463			19,669	113,051				
S16SR685	DE	START	180,743	110,887	219,553	328,220	436,886	100	105	9,211	3,331
		MIN	70,549	35,785	93,663	151,541	209,418				
		END	106,447	36,590	145,256	253,923	362,589				
	DF	START	210,751		202,127	310,794	419,461	100	105	9,211	3,340
		MIN	82,177		80,440	138,318	196,196				
		END	123,872		115,248	223,915	332,581				
	DG	START	280,812		160,827	269,494	378,160	100	115	9,211	3,353
		MIN	109,537		49,433	107,311	165,189				
		END	165,172		45,188	153,854	262,521				
	DH	START	353,858			228,203	336,870	100	120	9,211	3,369
		MIN	137,451			75,371	133,249				
		END	206,463			80,808	189,474				

* Maximum operating pressure (MOP) is the pressure required to produce the maximum rated torque of the actuator.
 ** Maximum Allowable Working Pressure (MAWP) is the maximum static pressure that may be applied to a fully stroked actuator against the travels stops.
 *** Swept Volume is the maximum volume including the cavity required for calculating consumption per 90 deg stroke.

HEAVY DUTY SYMMETRICAL YOKE SPRING RETURN TORQUE CHART

MODEL	SPRING CODE	SPRING	TORQUE OUTPUT IN-LBS				MOP*	MAWP**	SWEPT VOLUME CU. IN. ***	WEIGHT LBS	
			40 PSI	60 PSI	80 PSI	100 PSI					
S20SR585	EA	START	129,585	122,852	221,920	320,989	420,058	100	125	8,397	3,792
		MIN	50,224	48,423	101,188	153,954	206,720				
		END	75,286	68,552	167,621	266,689	365,758				
	EB	START	193,442	85,209	184,277	283,346	382,415	100	125	8,397	3,814
		MIN	75,161	20,162	72,927	125,693	178,459				
		END	112,929	4,695	103,764	202,833	301,902				
	EC	START	228,551		164,148	263,217	362,285	100	125	8,397	3,948
		MIN	88,676		57,514	110,279	163,045				
		END	133,058		68,656	167,724	266,793				
	ED	START	263,439		142,366	241,435	340,503	100	125	8,397	4,068
		MIN	102,721		41,806	94,572	147,338				
		END	154,840		33,767	132,835	231,904				
EE	START	302,789			218,000	317,069	100	125	8,397	4,090	
	MIN	118,171			77,104	129,870					
	END	178,275			93,485	192,554					
EF	START	345,653			192,924	291,993	100	125	8,397	4,266	
	MIN	134,843			58,176	110,942					
	END	203,350			50,622	149,691					
EG	START	391,117				265,253	100	125	8,397	4,431	
	MIN	152,577				90,834					
	END	230,090				104,227					
S20SR635	EB	START	193,442	120,526	237,253	353,980	470,707	100	125	9,894	4,034
		MIN	75,161	38,972	101,143	163,314	225,485				
		END	112,929	40,012	156,740	273,467	390,194				
	EC	START	228,551		217,124	333,851	450,578	100	125	9,894	4,169
		MIN	88,676		85,729	147,900	210,071				
		END	133,058		121,631	238,358	355,086				
	ED	START	263,439		195,342	312,069	428,796	100	125	9,894	4,288
		MIN	102,721		70,022	132,193	194,364				
		END	154,840		86,742	203,470	320,197				
	EE	START	302,789		171,907	288,634	405,361	100	125	9,894	4,310
		MIN	118,171		52,554	114,725	176,896				
		END	178,275		47,392	164,120	280,847				
	EF	START	345,653			263,559	380,286	100	125	9,894	4,486
		MIN	134,843			95,797	157,968				
		END	203,350			121,256	237,983				
	EG	START	391,117			236,819	353,546	100	125	9,894	4,652
		MIN	152,577			75,690	137,861				
		END	230,090			75,792	192,519				
EH	START	522,105				276,857	100	125	9,894	4,729	
	MIN	203,548				80,004					
	END	306,779				61,531					
S20SR685	EC	START	228,551	138,608	274,441	410,275	546,108	100	125	11,513	4,306
		MIN	88,676	43,911	116,258	188,605	260,952				
		END	133,058	43,116	178,949	314,782	450,615				
	ED	START	263,439		252,659	388,493	524,326	100	125	11,513	4,425
		MIN	102,721		100,550	172,897	245,245				
		END	154,840		144,060	279,893	415,727				
	EE	START	302,789		229,225	365,058	500,891	100	125	11,513	4,447
		MIN	118,171		83,083	155,430	227,777				
		END	178,275		104,710	240,543	376,377				
	EF	START	345,653		204,149	339,982	475,816	100	125	11,513	4,623
		MIN	134,843		64,155	136,502	208,849				
		END	203,350		61,847	197,680	333,513				
	EG	START	391,117			313,242	449,075	100	125	11,513	4,788
		MIN	152,577			116,394	188,741				
		END	230,090			152,216	288,049				
	EH	START	522,105			236,553	372,387	100	125	11,513	4,866
		MIN	203,548			58,538	130,885				
		END	306,779			21,228	157,061				

* Maximum operating pressure (MOP) is the pressure required to produce the maximum rated torque of the actuator.

** Maximum Allowable Working Pressure (MAWP) is the maximum static pressure that may be applied to a fully stroked actuator against the travels stops.

*** Swept Volume is the maximum volume including the cavity required for calculating consumption per 90 deg stroke.

NOTE: Heavy Duty Canted Yoke Torque Chart may be found on our website www.atcontrols.com.

HEAVY DUTY SYMMETRICAL YOKE SPRING RETURN TORQUE CHART (cont.)

MODEL	SPRING CODE		TORQUE OUTPUT IN-LBS				MOP*	MAWP**	SWEPT VOLUME CU. IN. ***	WEIGHT LBS	
			SPRING	40 PSI	60 PSI	80 PSI					100 PSI
S20SR735	ED	START	263,439	157,933	314,319	470,706	627,093	100	120	13,255	4,575
		MIN	102,721	50,097	133,392	216,686	299,980				
		END	154,840	49,334	205,720	362,107	518,493				
	EE	START	302,789		290,885	447,271	603,658	100	125	13,255	4,597
		MIN	118,171		115,924	199,218	282,512				
		END	178,275		166,370	322,757	479,143				
	EF	START	345,653		265,809	422,196	578,582	100	125	13,255	4,773
		MIN	134,843		96,996	180,290	263,585				
		END	203,350		123,507	279,894	436,280				
	EG	START	391,117		239,069	395,456	551,842	100	125	13,255	4,938
		MIN	152,577		76,888	160,183	243,477				
		END	230,090		78,043	234,430	390,816				
	EH	START	522,105			318,767	475,153	100	125	13,255	5,016
		MIN	203,548			102,327	185,621				
		END	306,779			103,441	259,828				
	EJ	START	654,978				398,453	100	125	13,255	5,126
		MIN	254,875				127,172				
		END	383,480				126,955				
S20SR785	EE	START	302,789	178,500	356,887	535,274	713,662	100	110	15,120	4,784
		MIN	118,171	56,066	151,078	246,090	341,102				
		END	178,275	53,985	232,373	410,760	589,147				
	EF	START	345,653		331,812	510,199	688,586	100	110	15,120	4,960
		MIN	134,843		132,150	227,162	322,175				
		END	203,350		189,509	367,897	546,284				
	EG	START	391,117		305,072	483,459	661,846	100	115	15,120	5,126
		MIN	152,577		112,042	207,055	302,067				
		END	230,090		144,045	322,433	500,820				
	EH	START	522,105			406,770	585,157	100	120	15,120	5,203
		MIN	203,548			149,199	244,211				
		END	306,779			191,444	369,832				
	EJ	START	654,978			330,069	508,457	100	125	15,120	5,313
		MIN	254,875			90,750	185,762				
		END	383,480			58,572	236,959				
S20SR835	EF	START	345,653	200,321	402,156	603,992	805,827	80	100	17,108	5,137
		MIN	134,843	62,116	169,617	277,118	389,619				
		END	203,350	58,018	259,854	461,690	663,525				
	EG	START	362,625		348,068	535,200	722,333	100	105	17,108	5,302
		MIN	141,680		134,175	230,650	327,126				
		END	213,329		198,772	385,904	573,037				
	EH	START	484,071		276,966	464,098	651,230	100	115	17,108	5,379
		MIN	182,671		82,253	178,728	275,203				
		END	284,431		77,326	264,458	451,591				
	EJ	START	607,264			392,985	580,117	100	120	17,108	5,490
		MIN	228,734			126,274	222,749				
		END	355,544			141,265	328,397				

* Maximum operating pressure (MOP) is the pressure required to produce the maximum rated torque of the actuator.
 ** Maximum Allowable Working Pressure (MAWP) is the maximum static pressure that may be applied to a fully stroked actuator against the travels stops.
 *** Swept Volume is the maximum volume including the cavity required for calculating consumption per 90 deg stroke.

NOTE: Heavy Duty Canted Yoke Torque Chart may be found on our website www.atcontrols.com.

HEAVY DUTY SYMMETRICAL YOKE SPRING RETURN TORQUE CHART

MODEL	SPRING CODE		TORQUE OUTPUT IN-LBS					MOP*	MAWP**	SWEPT VOLUME CU. IN. ***	WEIGHT LBS
			SPRING	40 PSI	60 PSI	80 PSI	100 PSI				
S27SR735	FA	START	276,471	261,796	472,918	684,040	895,162	100	125	17,895	CF
		MIN	107,092	103,091	215,538	327,985	440,433				
		END	160,447	145,773	356,895	568,017	779,139				
	FB	START	411,293		392,694	603,816	814,938	100	125	17,895	CF
		MIN	160,002		155,706	268,153	380,600				
		END	240,671		222,072	433,194	644,316				
	FC	START	552,941		312,471	523,593	734,714	100	125	17,895	CF
		MIN	214,184		93,735	206,182	318,629				
		END	320,895		80,424	291,546	502,668				
FD	START	680,939			443,369	654,491	100	125	17,895	CF	
	MIN	265,821			148,488	260,935					
	END	401,118			163,548	374,670					
S27SR785	FE	START	314,395	298,631	539,453	780,276	1,021,099	100	125	20,412	CF
		MIN	121,976	117,899	246,166	374,432	502,699				
		END	183,015	167,251	408,074	648,897	889,720				
	FF	START	472,445		447,946	688,769	929,592	100	125	20,412	CF
		MIN	183,122		176,581	304,848	433,114				
		END	274,523		250,024	490,847	731,670				
	FG	START	621,980		356,422	597,245	838,068	100	125	20,412	CF
		MIN	242,687		109,661	237,928	366,194				
		END	366,047		100,489	341,311	582,134				
FH	START	778,324			505,737	746,560	100	125	20,412	CF	
	MIN	303,516			168,878	297,145					
	END	457,554			184,967	425,790					
S27SR835	FJ	START	353,811	337,880	610,358	882,836	1,155,314	100	125	23,095	CF
		MIN	137,654	133,994	279,120	424,247	569,373				
		END	207,076	191,145	463,623	736,101	1,008,579				
	FK	START	532,431	234,334	506,812	779,290	1,051,768	100	125	23,095	CF
		MIN	206,804	55,325	200,452	345,578	490,705				
		END	310,622	12,525	285,003	557,481	829,959				
	FL	START	711,035		403,282	675,760	948,238	100	125	23,095	CF
		MIN	275,945		121,792	266,918	412,045				
		END	414,152		106,399	378,877	651,355				
FM	START	886,242			572,214	844,692	100	125	23,095	CF	
	MIN	344,458			189,319	334,445					
	END	517,698			203,670	476,148					
S27SR885	FN	START	399,823	379,561	685,648	991,735	1,297,822	100	115	25,944	CF
		MIN	155,074	149,779	312,807	475,834	638,861				
		END	232,613	212,351	518,438	824,525	1,130,612				
	FO	START	603,163		569,325	875,412	1,181,499	100	115	25,944	CF
		MIN	233,256		223,592	386,619	549,646				
		END	348,936		315,098	621,185	927,272				
	FP	START	792,838		453,018	759,106	1,065,193	100	115	25,944	CF
		MIN	308,883		138,661	301,688	464,716				
		END	465,243		125,424	431,511	737,598				
FR	START	1,001,281			642,799	948,886	100	115	25,944	CF	
	MIN	388,011			210,878	373,906					
	END	581,550			223,068	529,155					

* Maximum operating pressure (MOP) is the pressure required to produce the maximum rated torque of the actuator.

** Maximum Allowable Working Pressure (MAWP) is the maximum static pressure that may be applied to a fully stroked actuator against the travels stops.

*** Swept Volume is the maximum volume including the cavity required for calculating consumption per 90 deg stroke.

NOTE: Heavy Duty Canted Yoke Torque Chart may be found on our website www.atcontrols.com.

HEAVY DUTY SYMMETRICAL YOKE SPRING RETURN TORQUE CHART (cont.)

MODEL	SPRING CODE		TORQUE OUTPUT IN-LBS					MOP*	MAWP**	SWEPT VOLUME CU. IN. ***	WEIGHT LBS
			SPRING	40 PSI	60 PSI	80 PSI	100 PSI				
S27SR935	FS	START	447,328	423,657	765,307	1,106,957	1,448,608	100	110	28,958	CF
		MIN	173,288	166,852	348,821	530,789	712,758				
		END	259,644	235,972	577,623	919,273	1,260,923				
	FT	START	669,286		635,485	977,136	1,318,786	100	110	28,958	CF
		MIN	259,615		250,812	432,781	614,750				
		END	389,465		355,665	697,315	1,038,965				
	FU	START	894,672		505,648	847,298	1,188,948	100	110	28,958	CF
		MIN	346,585		151,726	333,695	515,664				
		END	519,303		130,278	471,929	813,579				
FV	START	1,109,805			717,476	1,059,126	100	110	28,958	CF	
	MIN	431,639			237,825	419,793					
	END	649,125			256,796	598,446					
S27SR985	FW	START	496,326	470,168	849,336	1,228,503	1,607,670	100	105	32,138	CF
		MIN	192,298	185,211	387,162	589,113	791,064				
		END	288,166	262,009	641,176	1,020,344	1,399,511				
	FX	START	735,949		705,260	1,084,428	1,463,595	100	110	32,138	CF
		MIN	286,852		280,493	482,444	684,395				
		END	432,242		401,553	780,720	1,159,887				
	FY	START	985,827		561,169	940,337	1,319,504	100	110	32,138	CF
		MIN	383,324		170,608	372,559	574,510				
		END	576,333		151,676	530,843	910,010				
FZ	START	1,225,450			796,261	1,175,429	100	110	32,138	CF	
	MIN	477,878			265,890	467,841					
	END	720,408			291,219	670,387					
S27SR1020	FAA	START	530,810	504,183	910,775	1,317,367	1,723,959	80	95	34,463	CF
		MIN	205,940	199,051	415,609	632,167	848,725				
		END	309,001	282,374	688,966	1,095,558	1,502,150				
	FAB	START	787,692		756,267	1,162,859	1,569,451	100	105	34,463	CF
		MIN	307,324		301,245	517,803	734,361				
		END	463,509		432,084	838,676	1,245,268				
	FAC	START	1,061,636		601,758	1,008,350	1,414,942	100	110	34,463	CF
		MIN	411,889		181,536	398,094	614,652				
		END	618,018		158,140	564,732	971,324				
FAD	START	1,318,502			853,858	1,260,450	100	110	34,463	CF	
	MIN	513,264			283,739	500,297					
	END	772,510			307,866	714,458					

* Maximum operating pressure (MOP) is the pressure required to produce the maximum rated torque of the actuator.
 ** Maximum Allowable Working Pressure (MAWP) is the maximum static pressure that may be applied to a fully stroked actuator against the travels stops.
 *** Swept Volume is the maximum volume including the cavity required for calculating consumption per 90 deg stroke.

NOTE: Heavy Duty Canted Yoke Torque Chart may be found on our website www.atcontrols.com.

Dimensions

P1758

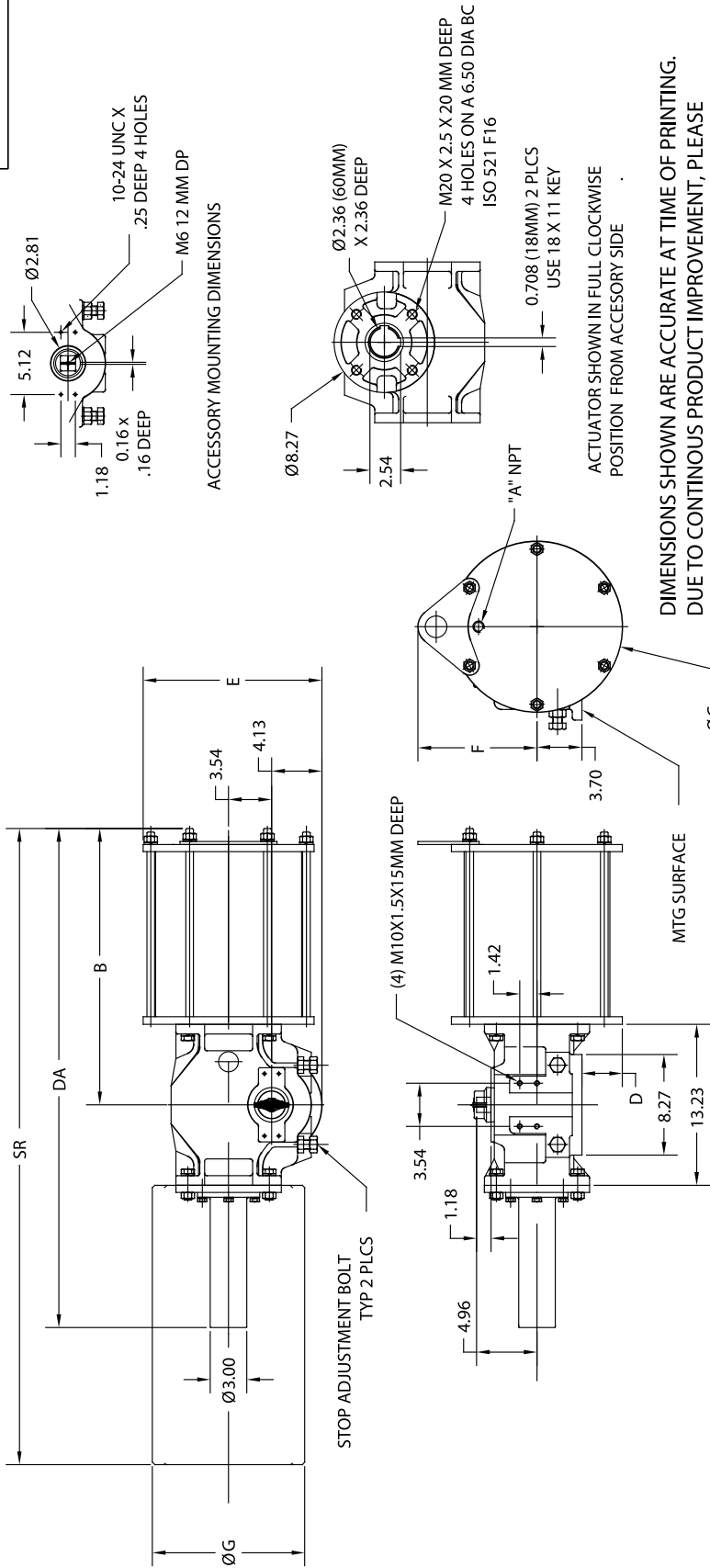

DIMENSIONS SHOWN ARE ACCURATE AT TIME OF PRINTING. DUE TO CONTINUOUS PRODUCT IMPROVEMENT, PLEASE CONTACT A-T CONTROLS FOR CURRENT DIMENSIONS.

ACTUATOR MODEL	A	B	DA	C DIA.	D	E	F	G DIA.	SR	SR
S09DA / SR200	3/8" NPT	22.36	40.67	10.24	1.42	12.80	7.56	10.53	200	280-335-385
S09DA / SR280	1/2" NPT	22.71	41.02	14.06	3.33	14.70	9.79	12.54	54.67	55.05
S09DA / SR335	1/2" NPT	22.75	41.06	16.14	4.37	15.75	10.81	12.54	58.60	58.99
S09DA / SR385	1/2" NPT	22.75	41.06	18.31	5.46	16.83	12.27	12.54		60.96

THE DESIGN AND DISCLOSURE CONTAINED IN THIS DRAWING WAS ORIGINATED BY AND IS EXCLUSIVE PROPERTY OF A-T CONTROLS, INC. IT IS FURNISHED FOR YOUR INFORMATION ONLY AND IS NOT AN AUTHORIZATION OR LICENSE TO MAKE THIS CONSTRUCTION OR TO FURNISH THIS INFORMATION TO OTHERS. ALL DRAWINGS MUST BE RETURNED TO A-T CONTROLS, INC. ON DEMAND. THIS DRAWING IS NOT TO BE REPRODUCED OR COPIED IN ANY FORM WITHOUT THE EXPRESS WRITTEN PERMISSION OF A-T CONTROLS, INC.

TRIAAC CONTROLS

Division of A-T Controls, Inc.
9955 International Blvd
Cincinnati, Ohio 45246
Phone: (513) 247-5465
Fax: (513) 247-5462

ECN#	DATE	BY
1379	08/05/2016	CMB
1325	08/01/2012	CHS

DRAWN BY	CHS	CHECKED BY	DWW
DATE	01/12/2011	DATE	01/12/2011
TITLE	TRIAAC 509200 THRU 509385 CATAOG DIMENSIONS DOUBLE ACTING AND SPRING RETURN		

TOLERANCE UNLESS OTHERWISE SPECIFIED:
TWO PLACE DECIMAL
DIM. Ø.02
THREE PLACE DECIMAL
DIM. Ø.010
ANGULAR DIM. 0 ±.30°
DO NOT SCALE DRAWINGS

P1625

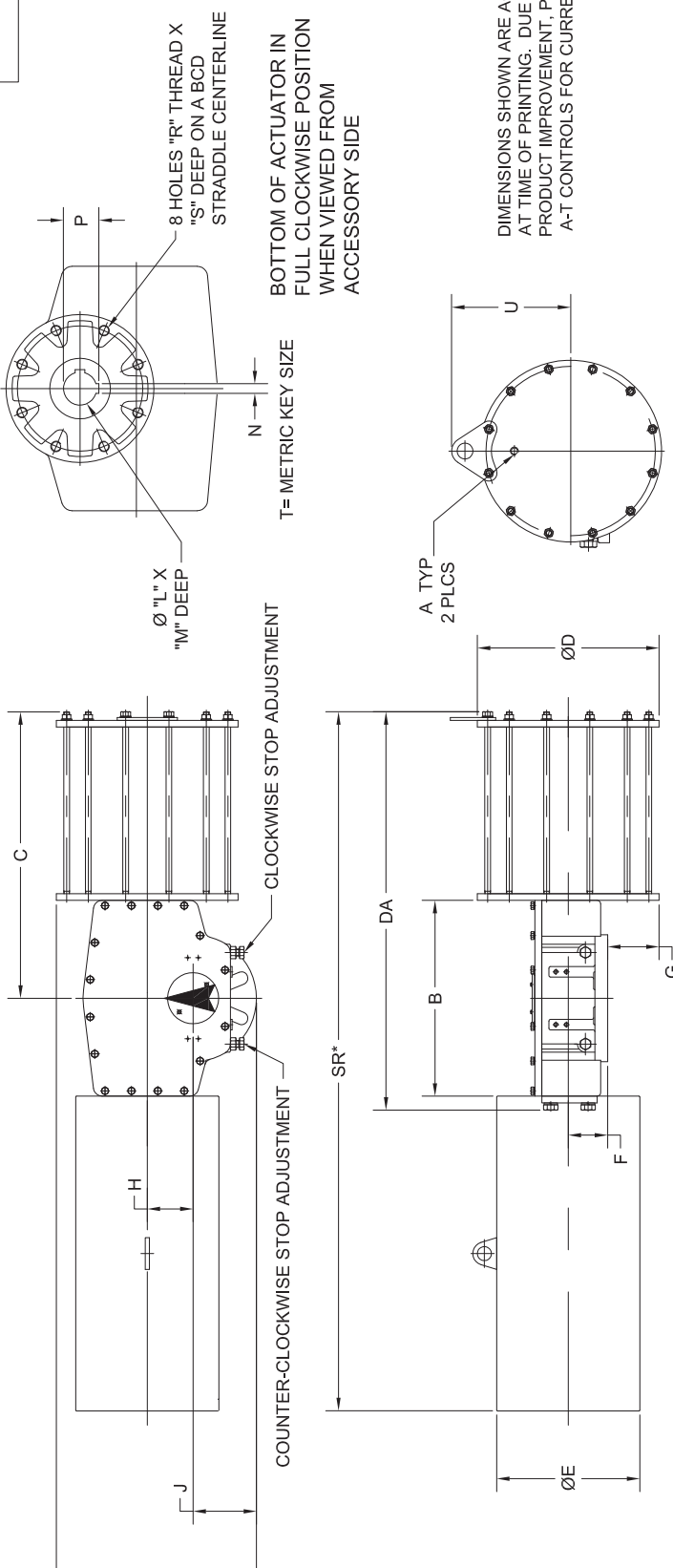

DIMENSIONS SHOWN ARE ACCURATE AT TIME OF PRINTING. DUE TO CONTINUOUS PRODUCT IMPROVEMENT, PLEASE CONTACT A-T CONTROLS FOR CURRENT DIMENSIONS

**"CJ" SPRING IS 7.87" LONGER

ACTUATOR MODEL	A	B	C	DA	SR*	D	E	F	G	H	J	K	L	M	N	P	R	S	B.C.D	T	U
S11DA / SR 280	1/2" NPT	19.21	28.27	38.98	76.36	14.06	14.00	4.35	2.70	4.33	5.91	17.26	2.95	5.51	0.79	3.15	M16	0.87	10.00	20 X 12	9.79
S11DA / SR 335	1/2" NPT	19.21	28.31	39.02	77.40	16.14	14.00	4.35	3.74	4.33	5.91	18.31	2.95	5.51	0.79	3.15	M16	0.87	10.00	20 X 12	10.81
S11DA / SR 385	1/2" NPT	19.21	28.42	39.14	77.52	18.31	14.00	4.35	4.83	4.33	5.91	19.39	2.95	5.51	0.79	3.15	M16	0.87	10.00	20 X 12	12.27
S11DA / SR 435	1/2" NPT	19.21	28.42	39.14	77.52	20.31	14.00	4.35	5.83	4.33	5.91	20.39	2.95	5.51	0.79	3.15	M16	0.87	10.00	20 X 12	13.32
S13DA / SR 385	1/2" NPT	21.89	32.24	44.43	86.61	18.31	16.00	4.41	4.75	5.12	7.09	21.36	3.54	6.30	0.87	3.76	M20	0.98	11.73	22 X 14	12.26
S13DA / SR 435	1/2" NPT	21.89	32.24	44.43	86.61	20.31	16.00	4.41	5.75	5.12	7.09	22.36	3.54	6.30	0.87	3.76	M20	0.98	11.73	22 X 14	13.33
S13DA / SR 485	3/4" NPT	21.89	32.80	44.98	87.17	22.76	16.00	4.41	6.97	5.12	7.09	23.58	3.54	6.30	0.87	3.76	M20	0.98	11.73	22 X 14	14.25
S13DA / SR 535	3/4" NPT	21.89	32.80	44.98	87.17	24.80	16.00	4.41	7.99	5.12	7.09	24.60	3.54	6.30	0.87	3.76	M20	0.98	11.73	22 X 14	15.33
S13DA / SR 585	1" NPT	21.89	33.19	45.38	87.56	27.24	16.00	4.41	9.18	5.12	7.09	25.79	3.54	6.30	0.87	3.76	M20	0.98	11.73	22 X 14	17.09
S13DA / SR 635	1" NPT	21.89	33.19	45.38	87.56	29.21	16.00	4.41	10.16	5.12	7.09	26.77	3.54	6.30	0.87	3.76	M20	0.98	11.73	22 X 14	18.05

THE DESIGN AND DISCLOSURE CONTAINED IN THIS DRAWING WAS ORIGINATED BY, AND IS EXCLUSIVE PROPERTY OF A-T CONTROLS, INC. IT IS FURNISHED FOR VENDOR INFORMATION ONLY AND IS NOT AN AUTHORIZATION TO REPRODUCE OR COPY IN ANY FORM WITHOUT THE EXPRESS WRITTEN PERMISSION OF A-T CONTROLS, INC.

Division of A-T Controls, Inc.
9955 International Blvd.
Cincinnati, OH 45246
Phone: (513) 247-5465
Fax: (513) 247-5462

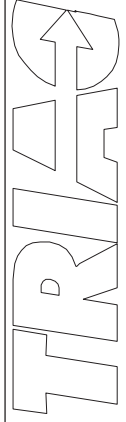

CONTROLS

TOLERANCE UNLESS OTHERWISE SPECIFIED:
TWO PLACE DECIMAL
DIM. ±0.02
THREE PLACE DECIMAL
DIM. ±0.010
ANGULAR DIM. ±0°-30"
DO NOT SCALE DRAWINGS

APPROVED	DATE
DWW	03/23/2009
CHS	03/23/2009
TITLE: S11 / S13 DIMENSIONAL DRAWING	

1322	08/01/2012	CHS
1281	05/16/2012	NPM
902	02/11/2010	CHS
859	10/13/2009	CHS
838	08/28/2009	CHS
829	08/05/2009	CHS
793	05/21/2009	CHS
ECN#	DATE	BY

Dimensions

P1626

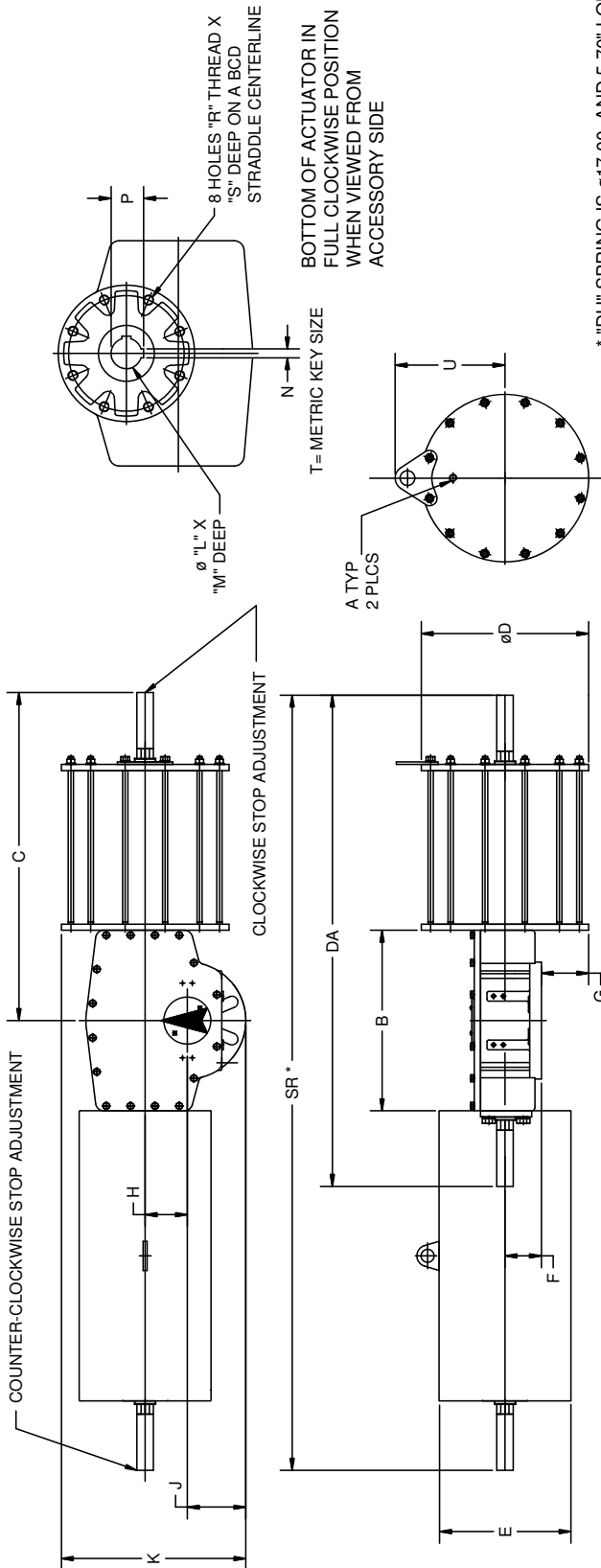

* "DH" SPRING IS $\phi 17.00$ AND 5.70" LONGER

ACTUATOR MODEL	A	B	C	DA	SR	D	E	F	G	H	J	K	L	M	N	P	R	S	B.C.D	T	U
S16DA / SR 485	3/4" NPT	27.32	45.67	68.74	106.90	22.76	16.00	5.51	5.87	6.30	8.27	25.94	4.33	7.87	1.26	4.62	M30	1.42	14.02	32 X 18	14.25
S16DA / SR 535	3/4" NPT	27.32	45.67	68.74	106.90	24.80	16.00	5.51	6.89	6.30	8.27	26.97	4.33	7.87	1.26	4.62	M30	1.42	14.02	32 X 18	15.53
S16DA / SR 585	3/4" NPT	27.32	45.98	69.06	106.90	27.17	16.00	5.51	8.07	6.30	8.27	28.15	4.33	7.87	1.26	4.62	M30	1.42	14.02	32 X 18	17.09
S16DA / SR 635	1" NPT	27.32	45.98	69.06	106.90	29.13	16.00	5.51	9.06	6.30	8.27	29.13	4.33	7.87	1.26	4.62	M30	1.42	14.02	32 X 18	18.04
S16DA / SR 685	1" NPT	27.32	45.98	69.06	106.90	31.30	16.00	5.51	10.14	6.30	8.27	30.22	4.33	7.87	1.26	4.62	M30	1.42	14.02	32 X 18	19.18
S20DA / SR 685	1" NPT	32.91	53.35	79.17	134.77	27.56	18.00	6.26	7.52	7.87	9.45	31.10	5.12	9.06	1.26	5.41	M36	1.69	15.98	32 X 18	
S20DA / SR 635	1" NPT	32.91	53.35	79.17	134.77	29.92	18.00	6.26	8.00	7.87	9.45	31.89	5.12	9.06	1.26	5.41	M36	1.69	15.98	32 X 18	
S20DA / SR 685	1" NPT	32.91	53.54	79.37	134.96	32.36	18.00	6.26	9.92	7.87	9.45	33.50	5.12	9.06	1.26	5.41	M36	1.69	15.98	32 X 18	
S20DA / SR 735	1" NPT	32.91	53.54	79.37	134.96	34.33	18.00	6.26	10.91	7.87	9.45	34.49	5.12	9.06	1.26	5.41	M36	1.69	15.98	32 X 18	
S20DA / SR 785	1" NPT	32.91	53.62	79.61	135.04	36.34	18.00	6.26	11.89	7.87	9.45	35.51	5.12	9.06	1.26	5.41	M36	1.69	15.98	32 X 18	
S20DA / SR 835	1" NPT	32.91	53.62	79.61	135.04	38.58	18.00	6.26	13.03	7.87	9.45	36.61	5.12	9.06	1.26	5.41	M36	1.69	15.98	32 X 18	
S27DA / SR 735	1" NPT	46.34	72.28	107.36	174.19	34.33	20.00	7.28	9.88	10.63	10.63	38.43	5.91	10.24	1.42	6.24	M36	2.13	19.02	36 X 20	
S27DA / SR 785	1" NPT	46.34	72.28	107.36	174.19	36.34	20.00	7.28	10.91	10.63	10.63	39.45	5.91	10.24	1.42	6.24	M36	2.13	19.02	36 X 20	
S27DA / SR 835	1" NPT	46.34	72.44	107.48	174.35	38.58	22.00	7.28	12.01	10.63	10.63	40.55	5.91	10.24	1.42	6.24	M36	2.13	19.02	36 X 20	
S27DA / SR 885	1" NPT	46.34	72.44	107.48	174.35	40.75	22.00	7.28	13.11	10.63	10.63	41.65	5.91	10.24	1.42	6.24	M36	2.13	19.02	36 X 20	
S27DA / SR 935	1" NPT	46.34	72.64	107.68	174.55	42.72	22.00	7.28	14.09	10.63	10.63	42.60	5.91	10.24	1.42	6.24	M36	2.13	19.02	36 X 20	
S27DA / SR 985	1" NPT	46.34	72.64	107.68	174.55	44.69	22.00	7.28	15.08	10.63	10.63	43.62	5.91	10.24	1.42	6.24	M36	2.13	19.02	36 X 20	
S27DA / SR1020	1" NPT	46.34	72.83	107.87	174.74	46.06	22.00	7.28	15.75	10.63	10.63	44.29	5.91	10.24	1.42	6.24	M36	2.13	19.02	36 X 20	

THE DESIGN AND DISCLOSURE CONTAINED IN THIS DRAWING WAS ORIGINATED BY AND IS EXCLUSIVE PROPERTY OF A-T CONTROLS, INC. IT IS FURNISHED FOR VENDOR INFORMATION ONLY AND IS NOT AN AUTHORIZATION OR LICENSE TO MAKE THIS CONSTRUCTION OR TO FURNISH THIS INFORMATION TO OTHERS. ALL DRAWINGS MUST BE RETURNED TO A-T CONTROLS, INC. ON DEMAND. THIS DRAWING IS NOT TO BE REPRODUCED OR COPIED IN ANY FORM WITHOUT THE EXPRESS WRITTEN PERMISSION OF A-T CONTROLS, INC.

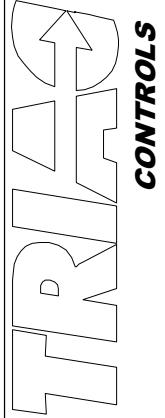

Division of A-T Controls, Inc.
9955 International Blvd.
Cincinnati, OH 45246
Phone: (513) 247-5465
Fax: (513) 247-5462

DATE: 03/23/2009
CHECKED BY: CHS
DATE: 03/23/2009
DRAWN BY: DWW
TITLE: S16 / S20 / S27 DIMENSIONAL DRAWING
DOUBLE ACTING AND SPRING RETURN

TOLERANCE UNLESS OTHERWISE SPECIFIED:
TWO PLACE DECIMAL
DIM: ± 0.02
THREE PLACE DECIMAL
DIM: ± 0.010
ANGULAR DIM: $\pm 0^{\circ}-30^{\circ}$
DO NOT SCALE DRAWINGS

ECN#	DATE	BY
1089	04/27/2011	CHS
854	10/13/2009	CHS
839	08/28/2009	CHS
828	08/05/2009	CHS
783	04/28/2009	CHS

Bill of Materials

NO.	QTY	SEAL KIT	DESCRIPTION	MATERIAL
1	1		HOUSING	A536 GR 65-45-12 DUCTILE IRON
2	1	*	YOKE PIN ACCESS PLUG O-RING	NBR NITRILE RUBBER
3	1		YOKE PIN ACCESS PLUG	304 STAINLESS STEEL
4	1	*	PINION TEFLON WASHER	RTFE
5	1	*	PINION SST WASHER	304 STAINLESS STEEL
6	1	*	PINION SNAP RING	STEEL ELECTROLESS NICKEL PLATED
7	1		PINION	ANSI 1045 CARBON STEEL
8	1	*	UPPER PINION O-RING	NBR NITRILE RUBBER
9	1	*	UPPER PINION BEARING	PTFE
10	1		YOKE / PINION KEY	ANSI 1045 CARBON STEEL
11	1		YOKE	A216 WCC CAST STEEL
12	1	*	LOWER PINION BEARING	PTFE
13	1	*	LOWER PINION O-RING	NBR NITRILE RUBBER
14	1		YOKE PIN	17-4 PH STAINLESS STEEL
15	1		LOWER YOKE PIN BUSHING	B505 C836 BRASS
16	1		UPPER YOKE PIN BUSHING	B505 C836 BRASS
17	1		YOKE PIN SNAP RING	STEEL ELECTROLESS NICKEL PLATED
18	2		STOP BOLT	ASTM A193 GRADE B7
19	2		STOP BOLT NUT	ASTM A194 GR 2H
20	2	*	CYLINDER O-RING	NBR NITRILE RUBBER
21	1		CYLINDER	A106 GR. A CHROME PLATED SEAMLESS CARBON PIPE
22	1		PISTON ROD	ANSI 1045 CHROME PLATED CARBON STEEL
23	1		BACK UP RING	PTFE
24	1	*	PISTON O-RING	NBR NITRILE RUBBER
25	1		END CAP	ASTM A36 CARBON STEEL
26	**		TIE ROD NUT	ASTM A194 GRADE 2H
27	1		PISTON NUT WITH SET SCREWS	ASTM A194 GRADE 2H
28	1		PISTON	ASTM A36 CARBON STEEL
29	2	*	PISTON ROD O-RING	NBR NITRILE RUBBER
30	**		TIE ROD	ANSI 1045 CARBON STEEL
31	1	*	PISTON ROD SEAL	NBR NITRILE RUBBER W/ PTFE SLEEVE
32	1		ADAPTER	ASTM A36 CARBON STEEL
33	1	*	S09200 ADAPTER O-RING	NBR NITRILE RUBBER
34	1	*	ADAPTER ROD BEARING	PTFE
35	1	*	ROD COVER BEARING	PTFE
36	1		ROD COVER ADAPTER	ASTM A36 CARBON STEEL
37	1		ROD COVER	A106 GR. A SEAMLESS CARBON STEEL PIPE
38	1		THRUST BEARING	B505 C836 BRASS
39	1		SPRING CARTDRIGE WELDMENT	A106 GR. A SEAMLESS CARBON STEEL PIPE
40	1		SPRING	SAE 9254 HEAT TREATED CARBON STEEL SPRING STEEL

SPRING RETURN

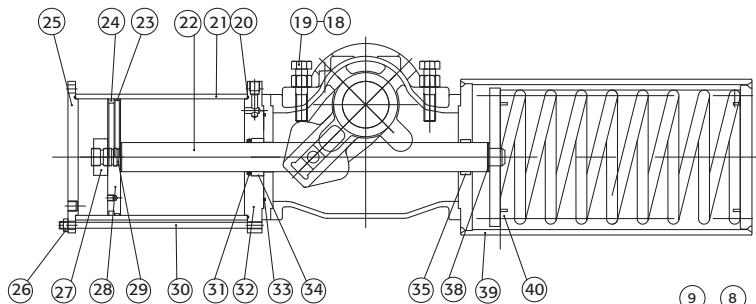

DOUBLE ACTING

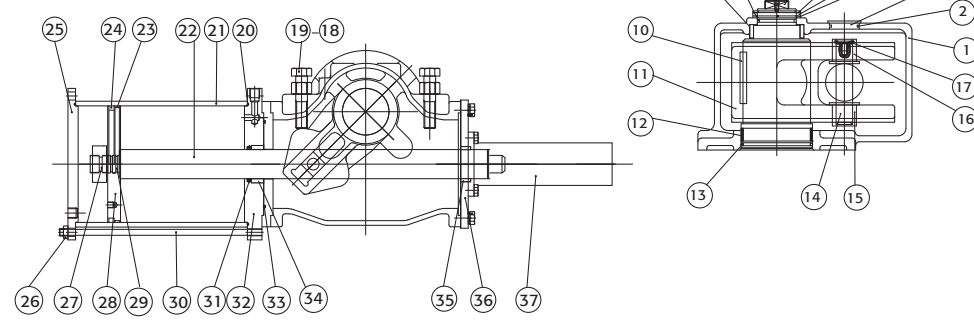

Bill of Materials

NO.	QTY	SEAL KIT	DESCRIPTION	MATERIAL
1	1		HOUSING	A536 GR 65-45-12
2	1		HOUSING COVER	ASTM A36 CARBON STEEL
3	1		YOKE	CAST STEEL
4	2		YOKE BUSHING	B505 C836 BRONZE
5	4	*	YOKE O-RING	NBR NITRILE RUBBER
6	1		INDICATOR PLATE	ASTM A36 CARBON STEEL
7	2		STOP BOLT	A193 GR. B7
8	2		STOP BOLT NUT	A194 GR. 2H
9	2	*	CYLINDER O-RING	NBR NITRILE RUBBER
10	1		CYLINDER	A106 GR. A CHROME PLATED
11	1		PISTON ROD	ANSI 4140 ALLOY CARBON STEEL
12	**		TIE ROD	ANSI 1045 ALLOY CARBON STEEL
13	1	*	PISTON O-RING	NBR NITRILE RUBBER
14	1		BACK UP RING	PTFE
15	1		END CAP	ASTM A36 CARBON STEEL
16	**		TIE ROD NUT	A194 GR. 2H
17	1		PISTON	ASTM A36 CARBON STEEL
18	1		ADAPTER	ASTM A36 CARBON STEEL
19	1		ALIGNMENT RING	C1018 CARBON STEEL
20	2		YOKE PIN BUSHING	B505 C836 BRONZE
21	1		YOKE PIN	17-4 PH STAINLESS STEEL
22	1		SLIDING BLOCK	ASTM A36 CARBON STEEL
23	2		SLIDING BLOCK BEARING	Du BEARING BRONZE / PTFE W/ STEEL BACKING
24	1		GUIDE BAR	ANSI 4140 ALLOY CARBON STEEL
25	1		SPRING PISTON ROD	ASNI 1045 ALLOY CARBON STEEL
26	1		SPRING PISTON ROD BEARING	Du BEARING BRONZE / PTFE W/ STEEL BACKING
27	1		THRUST BEARING	B505 C836 BRONZE
28	1		SPRING CYLINDER WELDMENT	A106 GR. A CARBON STEEL PIPE
29	1		SPRING	SAE 9254 HEAT TREATED CARBON STEEL SPRING
30	1		LOCK NUT ASSY	A194 GR. 8
31	1	*	PISTON ROD O-RING	NBR NITRILE RUBBER / PTFE
32	1		COVER PLATE	C1018 CARBON STEEL
33	1	*	ROD SEAL ASSEMBLY	NBR NITRILE RUBBER
34	1		ROD BEARING	Du BEARING BRONZE / PTFE W/ STEEL BACKING
35	1		DA COVER PLATE	ASTM A36 CARBON STEEL

SPRING RETURN

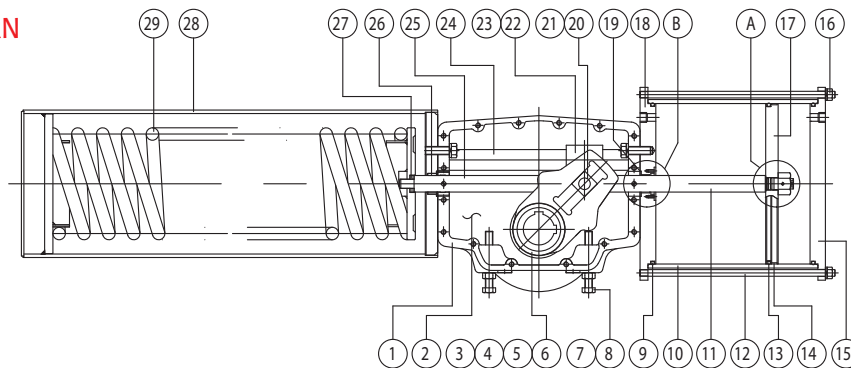

DOUBLE ACTING

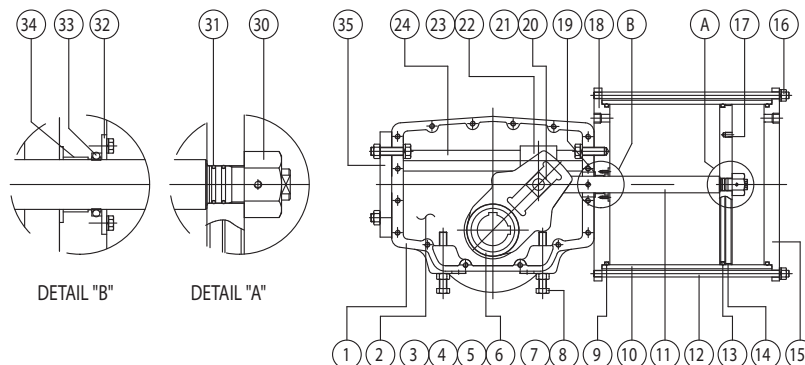

Bill of Materials

NO.	QTY	SEAL KIT	DESCRIPTION	MATERIAL
1	1		HOUSING	A536 GR 65-45-12
2	1		HOUSING COVER	ASTM A36 CARBON STEEL
3	1		YOKE	CAST STEEL
4	2		YOKE BUSHING	B505 C836 BRONZE
5	4	*	YOKE O-RING	NBR NITRILE RUBBER
6	1		INDICATOR PLATE	ASTM A36 CARBON STEEL
7	2		STOP BOLT	A193 GR. B7
8	2		STOP BOLT NUT	A194 GR. 2H
9	2	*	CYLINDER O-RING	NBR NITRILE RUBBER
10	1		CYLINDER	A106 GR. A CHROME PLATED
11	1		PISTON ROD	ANSI 4140 ALLOY CARBON STEEL
12	**		TIE ROD	ANSI 1045 ALLOY CARBON STEEL
13	1	*	PISTON O-RING	NBR NITRILE RUBBER
14	1		BACK UP RING	PTFE
15	1		END CAP	ASTM A36 CARBON STEEL
16	**		TIE ROD NUT	A194 GR. 2H
17	1		PISTON	ASTM A36 CARBON STEEL
18	1		ADAPTER	ASTM A36 CARBON STEEL
19	1		ALIGNMENT RING	C1018 CARBON STEEL
20	2		YOKE PIN BUSHING	B505 C836 BRONZE
21	1		YOKE PIN	17-4 PH STAINLESS STEEL
22	1		SLIDING BLOCK	ASTM A36 CARBON STEEL
23	2		SLIDING BLOCK BEARING	Du BEARING BRONZE / PTFE W/ STEEL BACKING
24	1		GUIDE BAR	ANSI 4140 ALLOY CARBON STEEL
25	1		SPRING PISTON ROD	ANSI 1045 ALLOY CARBON STEEL
26	1		SPRING PISTON ROD BEARING	Du BEARING BRONZE / PTFE W/ STEEL BACKING
27	1		THRUST BEARING	B505 C836 BRONZE
28	1		SPRING CYLINDER WELDMENT	A106 GR. A CARBON STEEL PIPE
29	1		SPRING	SAE 9254 HEAT TREATED CARBON STEEL SPRING
30	1		LOCK NUT ASSY	A194 GR. 8
31	2	*	PISTON ROD O-RING	NBR NITRILE RUBBER / PTFE
32	1		COVER PLATE	C1018 CARBON STEEL
33	1	*	ROD SEAL ASSEMBLY	NBR NITRILE RUBBER
34	1		ROD BEARING	Du BEARING BRONZE / PTFE W/ STEEL BACKING
35	1		DA COVER PLATE	ASTM A36 CARBON STEEL
36	2		STOP BOLT COVER	C1018 CARBON STEEL
37	2	*	STOP BOLT O-RING	NBR NITRILE RUBBER

SPRING RETURN

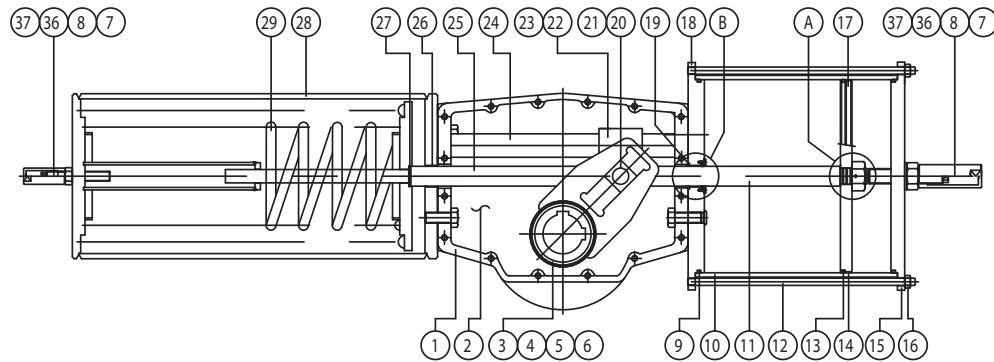

DOUBLE ACTING

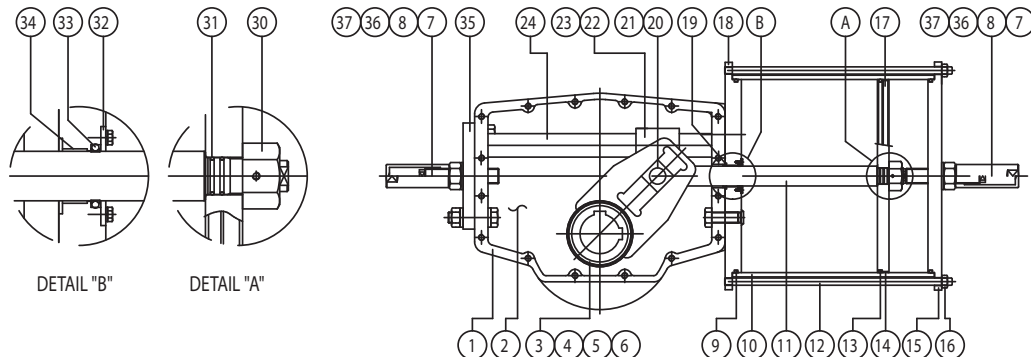

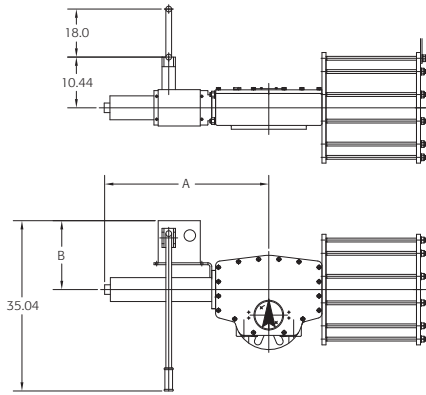

DA/Hydraulic Override

ACTUATOR MODEL	A	B
S11 DA XXX H	27.75	14.25
S13 DA XXX H	33.81	14.25
S16 DA XXX H	41.50	15.25
S20 DA XXX H	51.50	16.88
S27 DA XXX H	71.50	19.81

The mounting attitude must be specified at time of order to ensure the hydraulic reservoir and pump pickup are correctly located. Due to continuous product improvement, please contact A-T Controls for certified drawings with the most current dimensions and specifications.

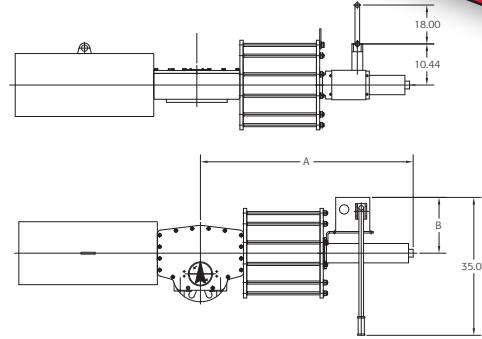

SR/Hydraulic Override

ACTUATOR MODEL	A	B
S11 SR XXX H	44.56	14.18
S13 SR XXX H	54.06	14.18
S16 SR XXX H	66.38	16.68
S20 SR XXX H	81.62	17.50
S27 SR XXX H	114.18	19.25

The mounting attitude must be specified at time of order to ensure the hydraulic reservoir and pump pickup are correctly located. Due to continuous product improvement, please contact A-T Controls for certified drawings with the most current dimensions and specifications.

Jackscrew Override

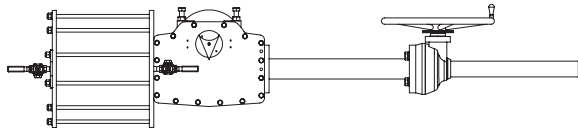

DOUBLE ACTING WITH JACKSCREW MANUAL OVERRIDE

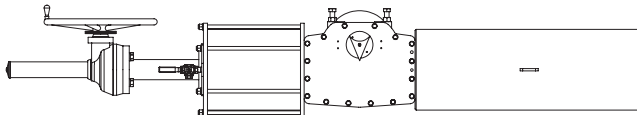

SPRING RETURN WITH JACKSCREW MANUAL OVERRIDE

PLEASE CONSULT OUR WEBSITE FOR DIMENSIONAL DETAILS.

Dec clutchable Manual Override

S09 PRESSURE GROUP ONLY

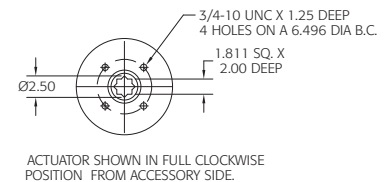
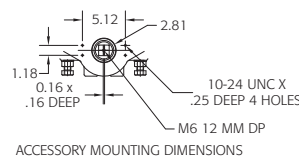
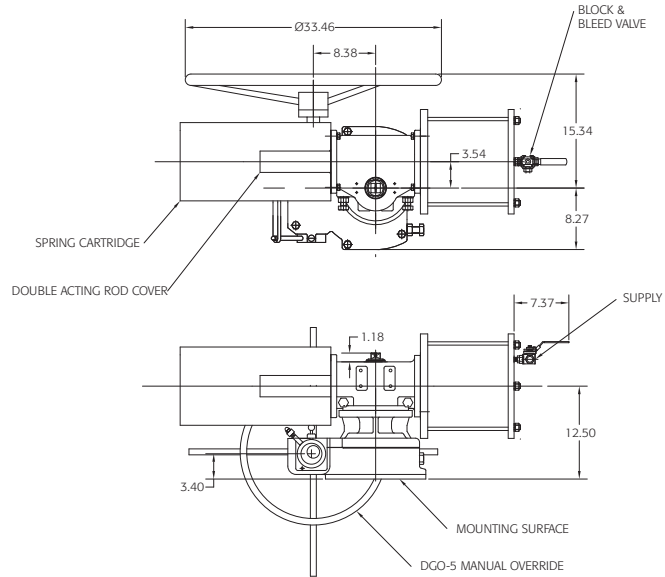

T H D S E R I E S
ACCESSORIES

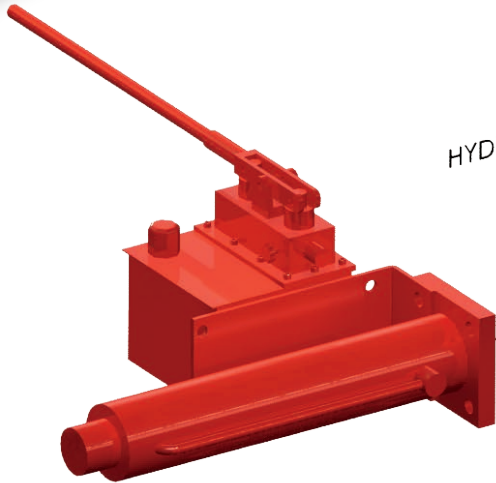

HYDRAULIC OVERRIDE
OPTION

JACKSCREW OVERRIDE
OPTION



PNEUMATIC OR ELECTRO-PNEUMATIC
POSITIONER OPTION

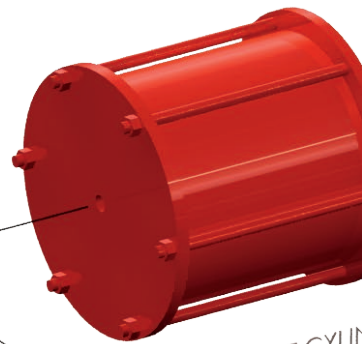

PRESSURE CYLINDER



FILTER-REGULATOR
OPTION



SOLENOID

ATIC

DIGITAL POSITIONER
OPTION

LIMIT SWITCH
OPTION

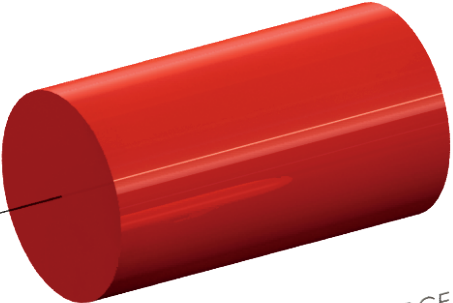
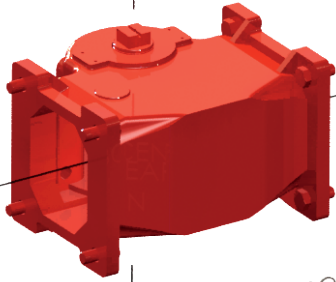

CENTER BODY

SPRING CARTRIDGE

CYLINDER

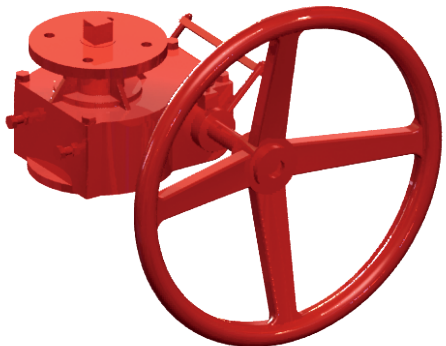

DECLUTCHABLE GEAR
OVERRIDE OPTION
509 BODY ONLY



FAIL-SAFE ACCUMULATOR
TANK OPTION

NOID OPTION

TRIAC Heavy Duty Actuators are available with numerous options and accessories including:

- Solenoid Valves
- Digital and Analog Positioners
- AS-Interface (AS-i)
- Spring Return - FCW and FCCW
- Filter Regulators
- Flow Control Valves
- Air Lockup Valves
- Air Failsafe Accumulator Systems
- Declutchable Gear Overrides
- Hydraulic Overrides
- Jackscrew Overrides
- Quick Open, Quick Close Circuits
- Low Temp and High Temp Seals and Grease
- Special Coatings Including Marine and High-Build Epoxy
- Control Boxes
- Limit Switches
- Position Transmitters

POPULAR SCHEMATICS

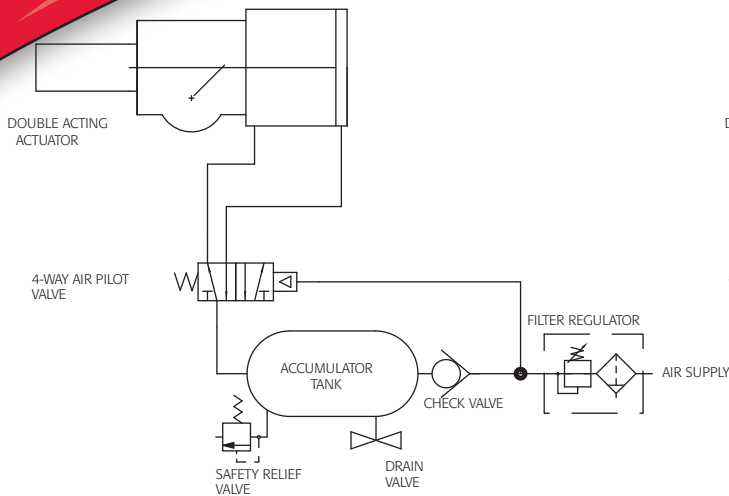

Air Failsafe 1

When air supply drops below 30 psi, the spool valve will shift and rotate the actuator to the failsafe position, either clockwise or counter-clockwise as specified by the customer for one each 90° cycle.

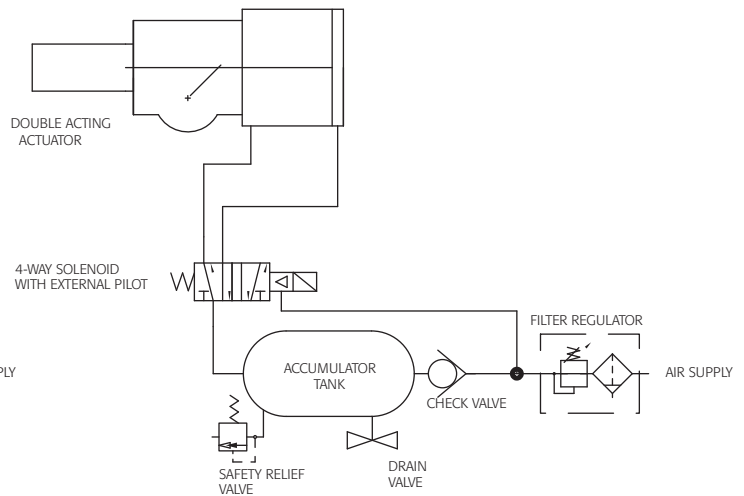

Air Failsafe 2

Upon loss of electric, or when air supply drops below 30 psi, the spool valve will shift and rotate the actuator to the failsafe position, either clockwise (as shown) or counter-clockwise as specified by the customer for one each 90° cycle.

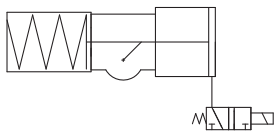

Spring return with 3-way solenoid valve

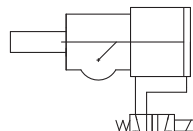

Double acting with 4-way solenoid valve

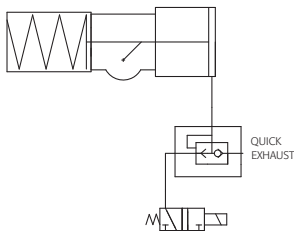

Spring return with quick exhaust valves and 3-way solenoid valve

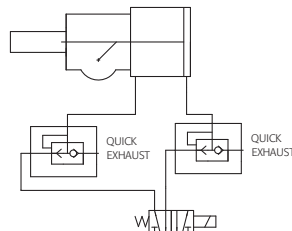

Double acting with quick exhaust valves and 4-way solenoid valve

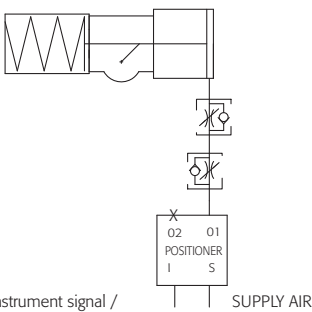

3-15 instrument signal / 4-20 mA instrument signal

Spring return with flow controls and positioner

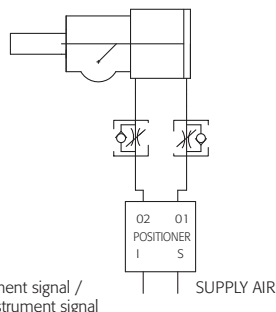

3-15 instrument signal / 4-20 mA instrument signal

Double acting with flow controls and positioner

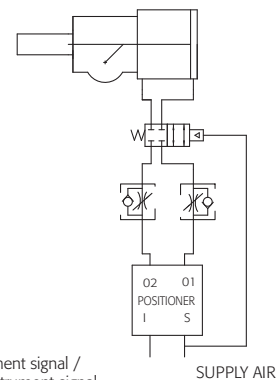

3-15 instrument signal / 4-20 mA instrument signal

Double acting with lockup valve, flow controls and positioner for use on double acting only

TRIAC THD Model Number Matrix

1	THD Series
S	Pneumatic Symmetrical Scotch Yoke
C	Pneumatic Canted Scotch Yoke (N/A in S09 model)

2	Model (Center Body)
09	
11	
13	
16	
20	
27	

3	Actuator Action
DA	Double Acting
SC	Spring Return Fail Clockwise
SO	Spring Return Fail Counter-Clockwise

4	Pneumatic Pressure Group
200	
280	
335	
385	
435	
485	
535	
585	
685	
735	
785	
835	
935	
985	
1020	

5	Spring Cartridge
Blank	Double Acting
Select spring code from spring return torque charts for specific actuator	

7	Seals & Grease
Blank	Standard Seals (-29°C to 93°C) (-20°F to 200°F)
V	High Temperature Seals (-18°C to 177°C) (0°F to 350°F)
L	Low Temperature Seals (-40°C to 82°C) (-40°F to 180°F)
L1	Low/High Temperature Seals (-50°C to 177°C) (-58°F to 350°F)

6	Manual Override
Blank	No Override
D	Declutchable Gear (S09 only)
J	Jackscrew
H	Hydraulic (N/A on S09)

8	Options
Blank	No Specials
M	Marine Epoxy Coating



Example: S 13 SC 435 CB H - L

S13SC435CBH-L: Triac S13 435 Pressure Group Heavy Duty Spring Return, Spring Cartridge SCS13CB, Spring Clockwise, Symmetrical Scotch Yoke Actuator with Travel Stop Adjustment in Both Directions, 11.73" Bolt Circle ISO 5211 Valve Mounting, 1/2" NPT Air Supply Connection Complete with Hydraulic Override and Low Temperature Seals



Other A-T Controls products include:

Electric Actuators



Gear Operators

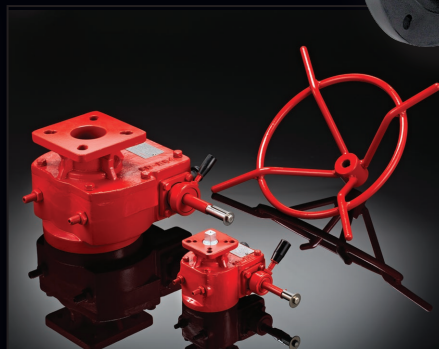

Rack and Pinion Actuators



Automated Ball Valve Packages



A-T Controls, Inc.

9955 International Blvd.
Cincinnati, OH 45246
PH: 513 - 247 - 5465
FAX: 513 - 247 - 5462
sales@atcontrols.com

www.atcontrols.com

THD-20240412
Copyright 2013 A-T Controls, Inc.
LIT0006

