

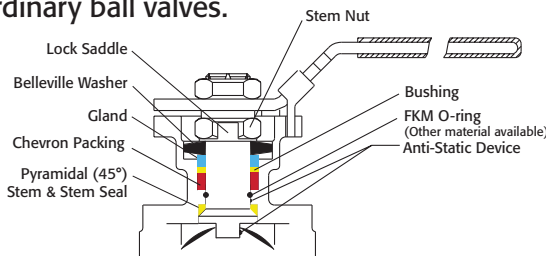

Triac 90 Series Flanged Ball Valves feature a split body design. The high quality investment castings feature a fully machined bore. The superior live-loaded packing system is accomplished with Belleville washers, "V" ring packing and a unique primary pyramidal stem seal. This advanced sealing system provides protection against stem leaks experienced by ordinary ball valves.



RTFE seats are standard, but various options are available for seat materials. The 50/50 STFE seat option is excellent for services that call for higher temperatures and more difficult applications including steam. Call us for details.

HOW TO ORDER MANUAL VALVES

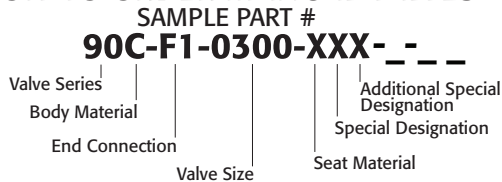

See part number matrix for itemized options

Easy to Automate!

See automated data sheets for pre-sized assemblies



Pneumatic



Electric



Series 90/93* Split Body Flanged Ball Valve

Sizes 1/2" – 12"

ASME Class 150

Full Port Design

316SST, WCB, Alloy 20 or Hastelloy
C-276 (1/2" - 4")

Superior Live Loaded Packing System

ISO 5211 Actuator Mounting Pad

Blowout Proof Stem w/ Dual Anti-Static
Devices

RTFE Seats Standard

Pyramidal Stem Seal Design

Monel Ball & Stem Available

Lockable Manual Handle



STANDARDS

Design	ASME B16.34 (fully conforms)
Face to Face	ASME B16.10
Flange Dimensions	ASME B16.5
Pressure Testing	API 598
Mounting	ISO 5211
CE Approval	2014/68/EU Module H
Safety Integrity	SIL 3; IEC 61508:2010 (90 Series only)
Material Certification	EN 10204-3.1 MTR
Quality Assurance	ISO 9001:2015
Gas Shut-off Valves	CSA 3.16:21 (6" Series 93 only)

TABLE OF CONTENTS:

- Page 2 - Materials & Dimensions
- Page 3 - Technical Data
- Page 4 - Double Acting
- Page 5 - Spring Return
- Page 6 - Electric
- Page 7 - How to Order - Manual
- Page 8 - How to Order - Automated

*Series 93 denotes sand cast 6"-12". TA-Luft certification applies to Series 90 only.



MATERIALS LIST

NO.	PART NAME	QTY	STAINLESS STEEL	CARBON STEEL	ALLOY 20	HASTELLOY C-276	REPAIR KIT
1	BODY	1	ASTM A351 GRADE CF8M	ASTM A216 GRADE WCB	ASTM A351 GRADE CN7M	ASTM A494 Grade CW12MW	
2	END CAP	1	ASTM A351 GRADE CF8M	ASTM A216 GRADE WCB	ASTM A351 GRADE CN7M	ASTM A494 Grade CW12MW	
3	BALL	1	ASTM A351 GRADE CF8M	ASTM A351 GRADE CF8M	ASTM A351 GRADE CN7M	ASTM A494 Grade CW12MW	
4	SEAT	2	RTFE	RTFE	RTFE	TFM™-1600	✓
5	JOINT GASKET	1	TFM™-1600	TFM™-1600	TFM™-1600	TFM™-1600	✓
6	STEM (1/2" - 4")	1	ASTM A276 316SST	ASTM A276 316SST	ASTM A351 GRADE CN7M	UNS N10276	
6	STEM (6" - 12")	1	17-4PH	17-4PH	N/A	N/A	
7	STEM SEAL	1	TFM™-1600	TFM™-1600	TFM™-1600	TFM™-1600	✓
8	GLAND PACKING	1^	PTFE	PTFE	PTFE	TFM™-1600	✓
9	GLAND WASHER	1	RTFE	RTFE	RTFE	TFM™-1600	✓
10	GLAND BUSHING	1	AISI 304	AISI 304	AISI 304	AISI 316	
11	BELLEVILLE WASHER	2	AISI 301	AISI 301	AISI 301	AISI 301	
12	LOCKING PLATE	1	AISI 304	AISI 304	AISI 304	AISI 316	
13	LOCK SADDLE	1	AISI 304	AISI 304	AISI 304	AISI 316	
14	STEM NUT	1	AISI 304	AISI 304	AISI 304	AISI 316	
15	HANDLE LOCK	1	AISI 304	AISI 304	AISI 304	AISI 316	
16	HANDLE	1	AISI 304	AISI 304	AISI 304	AISI 316	
17	HANDLE SLEEVE	1	VINYL	VINYL	VINYL	VINYL	
18	STOP BOLT	1	AISI 304	AISI 304	AISI 304	AISI 316	
19	Body Bolts	1/2"-2"	ASTM A193 GRADE B8				ISO 3506-1 A4-70
		2 1/2"-4"	ISO 3506-1 A2-70				
		6"-12"	ASTM A193 GRADE B8	ASTM A193 GRADE B7	ASTM A193 GRADE B8	N/A	
20	Body Nuts	1/2"-2"	ASTM A194 GRADE 8				ISO 3506-2 A4-70
		2 1/2"-4"	ISO 3506-2 A2-70				
		6"-12"	ASTM A194 GRADE 8	ASTM A194 GRADE 2H	ASTM A194 GRADE 8	N/A	
21	O-RING	1**	FKM	FKM	FKM	FKM	✓
22	HANDLE NUT	1	AISI 304	AISI 304	AISI 304	AISI 316	
23	ANTI-STATIC DEVICE	2	AISI 316	AISI 316	AISI 316	AISI 316	

*QTY = 8 PCS for 2-1/2" THRU 6" » Call for material details » See website for Series 93

**QTY = 0 PCS for 6" THRU 12" on Hastelloy C-276 valves bill of material drawing

QTY = 12 PCS for 8"

QTY = 16 PCS for 10" THRU 12"

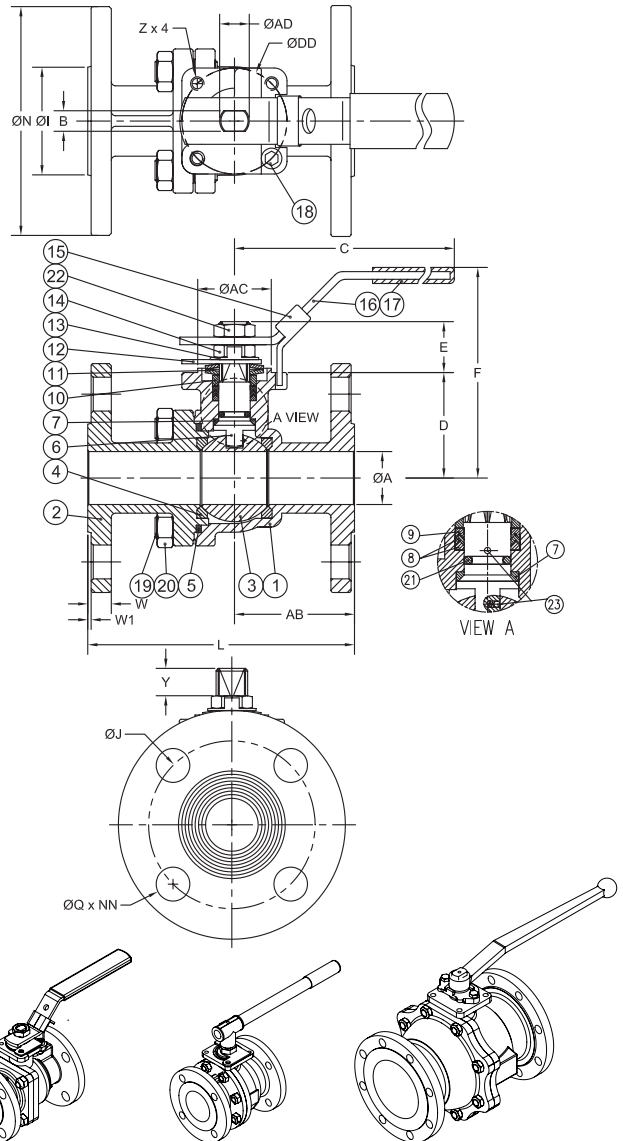

BENT HANDLE SIZES 1/2" - 2-1/2" PIPE HANDLE SIZES 3" - 4"

CAST HANDLE SIZES 6"

NOTE: A-T CONTROLS RECOMMENDS A GEAR FOR 6" VALVES AND LARGER. 6" SERIES 93 VALVES DO NOT HAVE LOCKABLE HANDLES.

DIMENSIONS (IN)

INVESTMENT CAST BODY (Series 90)

SIZE	A	B	C	D	E	F	I	J	L	N	Q	W	W1	Y	Z	AB	AC	AD	DD	NN (LBS)	ISO 5211	
1/2"	0.59	0.315	6.69	1.34	0.92	3.15	1.47	2.38	4.26	3.50	0.63	0.44	0.06	0.36	M5	1.82	1.17	0.43	1.654	4	3.7	F04
3/4"	0.79	0.315	6.69	1.65	0.94	3.43	1.82	2.75	4.62	3.88	0.63	0.44	0.06	0.40	M5	2.17	1.17	0.43	1.654	4	4.6	F04
1"	0.98	0.382	8.05	1.95	0.94	3.85	2.08	3.13	5.00	4.26	0.63	0.44	0.06	0.42	M6	2.20	1.37	0.56	1.969	4	6.8	F05
1-1/2"	1.50	0.472	10.28	3.08	1.37	6.02	2.88	3.88	6.50	5.00	0.63	0.56	0.06	0.58	M8	2.81	2.17	0.75	2.756	4	13.6	F07
2"	1.97	0.472	10.28	3.40	1.37	6.38	3.62	4.75	7.02	6.00	0.75	0.63	0.06	0.58	M8	3.38	2.17	0.75	2.756	4	19.2	F07
2-1/2"	2.56	0.472	10.28	3.83	1.37	6.81	4.12	5.50	7.49	7.00	0.75	0.69	0.06	0.58	M8	3.02	2.17	0.75	2.756	4	30.0	F07
3"	3.15	0.591	13.94	4.23	1.81	6.95	5.00	6.00	8.01	7.50	0.75	0.75	0.06	0.93	M10	4.01	2.76	0.94	4.016	4	41.0	F10
4"	3.94	0.591	13.94	4.82	1.79	7.52	6.19	7.50	9.04	9.00	0.75	0.94	0.06	0.93	M10	4.06	2.76	0.94	4.016	8	65.0	F10

SAND CAST BODY (Series 93)

6"	6.00	0.910	21.00	6.61	2.64	11.25	8.50	9.50	15.51	10.98	0.87	1.00	0.06	1.57	1/2-13	7.06	CF	1.64	4.921	8	168.0	F12
8"	8.00	0.910	N/A	8.86	2.40	13.26	10.63	11.75	17.99	13.50	0.87	1.13	0.06	1.26	1/2-13	8.40	CF	1.64	4.921	8	232.0	F12
10"	9.84	1.181	N/A	10.43	3.94	15.86	12.76	14.25	20.98	15.95	0.98	1.21	0.06	1.42	5/8-11	CF	CF	1.97	5.512	12	430.0	F14
12"	11.81	1.378	N/A	12.83	4.09	18.18	15.00	17.00	24.02	19.02	0.98	1.25	0.06	1.50	5/8-11	CF	CF	1.97	5.512	12	551.0	F14

Series 93 Note:

Due to differences between sand cast and investment cast valves, A-T Controls requires that each valve be measured for the correct stem height and width before making a mounting adaption.

Standard manual valves should be ordered with an automation gland if A-T Controls is not making the mounting kit.

Dimensions B, E, and Y are for reference only.

High Performance, Full Port Split Body Flanged Ball Valve Series 90/93 (ASME Class 150)

Series 90/93

**Pressure vs. Temperature - Series 90/93
Seat Pressure Ratings**

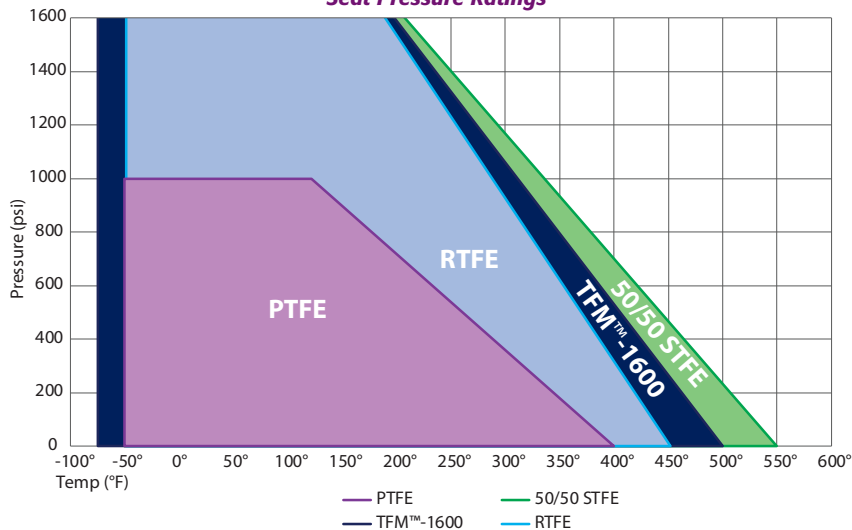

Temp	Pressure - Seat Material			
	RTFE	STFE	PTFE	TFM™-1600
-75°				2000
-50°	2000	2000	1000	2000
100°	2000	2000	1000	2000
122°	2000	2000	1000	2000
150°	1829	1869	899	1852
200°	1524	1636	719	1587
250°	1220	1402	540	1323
300°	915	1168	360	1058
350°	610	935	180	794
400°	305	701	0	529
450°	0	467		265
500°		234		0
550°		0		

**Pressure vs. Temperature - Series 90/93
Body & End Cap Ratings ASME B16.34**

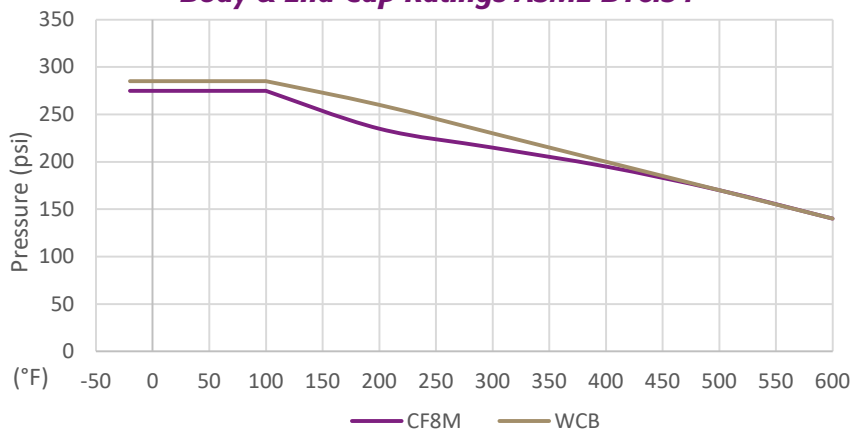

Temp	CF8M psi	WCB psi
-20°	275	285
100°	275	285
200°	235	260
300°	215	230
400°	195	200
500°	170	170
600°	140	140

90/93 Component Temperature Ratings

COMPONENT	MATERIAL	TEMPERATURE
Stem Packing	PTFE	-50°F to 450°F
Stem Seal	TFM™-1600	-75°F to 500°F
Gaskets	TFM™-1600	-75°F to 500°F
Seats (Other Materials Available)	PTFE	-50°F to 400°F
	RTFE (standard)	-50°F to 450°F
	TFM™-1600	-75°F to 500°F
	50/50 STFE	-50°F to 550°F
O-Rings	FKM (standard)	-20°F to 450°F
	Markez® Z1028	5°F to 608°F
	Kalrez® 4079	30°F to 600°F
	Chemraz® 505	-22°F to 446°F
	Kalrez® 6375	-4°F to 527°F
	Perlast® G75M	5°F to 500°F
	Chemraz® 564	-40°F to 445°F
	Low Temp Buna	-65°F to 275°F
	EPDM	-70°F to 250°F
	Silicone	-60°F to 400°F

NOTE: At temperature, valves are limited by either the valve body/end cap pressure ratings, seat pressure ratings, or packing/stem seal/gaskets; whichever is lower.

VALVE SIZE	VALVE Cv
1/2"	15
3/4"	45
1"	85
1-1/2"	275
2"	460
2-1/2"	700
3"	1,100
4"	2,200
6"	5,150
8"	10,000
10"	15,000
12"	21,000

BREAKAWAY TORQUES	
SIZE	IN-LBS
1/2"	45
3/4"	73
1"	91
1-1/2"	230
2"	297
2-1/2"	535
3"	768
4"	1250
6"	4,800
8"	10,300
10"	18,000
12"	24,209

Published torques are based on full differential pressure with clean water. Consult the Application Sizing Guide for assistance with sizing actuators.

Pneumatic Double Acting Automated Ball Valve Package

Series 90/93

ASME Class 150 Flanged Ball Valve

- Sizes 1/2" - 12"
- Available in 316SST, WCB or Alloy 20
- ASME Class 150
- Full Port Design
- Superior Live Loaded Packing System
- Blowout Proof Stem w/ Dual Anti-Static Devices
- RTFE Seats Standard
- Pyramidal Stem Seal Design
- Monel Ball & Stem Available

STANDARDS

Design	ASME B16.34 (fully conforms)
Face to Face	ASME B16.10
Flange Dimensions	ASME B16.5
Pressure Testing	API 598
Mounting	ISO 5211
CE Approval	2014/68/EU Module H
Safety Integrity	SIL 3; IEC 61508:2010 (90 Series only)
Material Certification	EN 10204-3.1 MTR
Quality Assurance	ISO 9001:2015
Gas Shut-off Valves	CSA 3.16:21 (6" Series 93 only)



ASME Class 150 Flanged

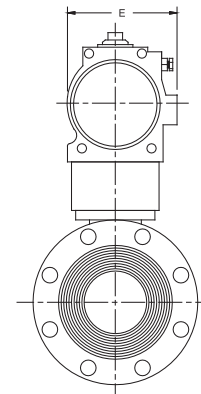
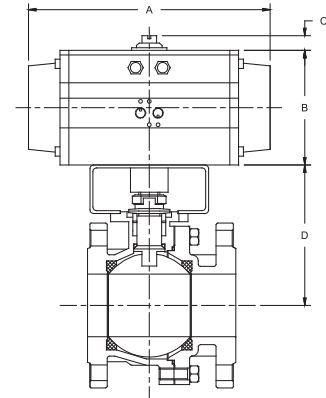

DIMENSIONS (IN)

VALVE SIZE	A	B	C	D	E	VALVE Cv
1/2"	6.50	2.84	0.787	2.82	2.82	15
3/4"	6.50	2.84	0.787	3.22	2.82	45
1"	6.50	2.84	0.787	4.12	2.82	85
1-1/2"	7.60	3.47	0.787	5.05	3.35	275
2"	7.60	3.47	0.787	5.37	3.35	460
2-1/2"	9.29	4.30	0.787	5.80	4.18	700
3"	11.02	4.61	0.787	6.85	4.27	1,100
4"	11.50	5.28	0.787	7.44	4.78	2,200
6"	16.89	7.36	1.181	10.61	6.38	5,150
8"	23.54	10.08	1.181	12.21	8.90	10,000

DIMENSIONS SHOWN ARE FOR ASSEMBLIES SIZED FOR 80 PSI SUPPLY



SERIES 90/93 150# Flanged

SIZED FOR 80 psi AIR SUPPLY	
SIZE	MODEL
1/2"	90-F1-050/3RDD-XX
3/4"	90-F1-075/3RDD-XX
1"	90-F1-100/3RDD-XX
1-1/2"	90-F1-150/3RED-XX
2"	90-F1-200/3RED-XX
2-1/2"	90-F1-250/3RFD-XX
3"	90-F1-300/3RGD-XX
4"	90-F1-400/3RHD-XX
6"	93-F1-600/3RLD-XX-A
8"	93-F1-800/3RRD-XX-A

SIZED FOR 60 psi AIR SUPPLY	
SIZE	MODEL
1/2"	90-F1-050/3RDD-XX
3/4"	90-F1-075/3RDD-XX
1"	90-F1-100/3RDD-XX
1-1/2"	90-F1-150/3RED-XX
2"	90-F1-200/3RFD-XX
2-1/2"	90-F1-250/3RFD-XX
3"	90-F1-300/3RGD-XX
4"	90-F1-400/3RJD-XX
6"	93-F1-600/3RND-XX-A
8"	93-F1-800/3RSDD-XX-A

Series 90 denotes investment cast / Series 93 denotes sand cast

OPTIONS		
SUFFIX 1	Accessories/Options	Model no.
X	No Specials	
A	TYPE 4 Solenoid 120VAC	TVCS-X411-4N-A120
B	TYPE 7 Solenoid 120VAC	TVCS-X411-7N-A120
C	Intrinsically Safe Solenoid	TVIS-X411-4N-D24
D	TYPE 4 Solenoid 24VDC	TVCS-X411-4N-D24
F	TYPE 7 Solenoid 24VDC	TVCS-X411-7N-D24
Q	TYPE 4 SST Solenoid 120VAC	TVSS-X411-4N-A120
M	TYPE 7 SST Solenoid 120VAC	TVSS-X411-7N-A120
L	TYPE 4 SST Solenoid 24VDC	TVSS-X411-4N-D24
N	TYPE 7 SST Solenoid 24VDC	TVSS-X411-7N-D24
P	Pneumatic Positioner	PPR-1200
E	Electro-Pneumatic Positioner	EPR-1000
SUFFIX 2	Accessories	Model no.
X	No Specials	
A	TYPE 4 Limit Switch	APL-210N
B	TYPE 7 Limit Switch	APL-510N
C	Intrinsically Safe Limit Switch	APL-218N
Q	TYPE 4 SST Limit Switch	APL-910N
M	TYPE 7 SST Limit Switch	APL-510S
H	NEMA 4 Std. Enc.	APL-310N

Other options available - call for details
Actuators are sized based on full differential pressure with clean water. Consult the Application Sizing Guide for assistance with sizing actuators.

SAMPLE PART #
90C-F1-150/3RED-XX

Valve Series | Carbon Steel | End Connection | Seat Material | Valve Size | TRIAC Actuator Series | Actuator Size | Double Acting

See automated part number matrix on back cover for complete part number and options.

SUFFIX 1: Solenoids
SUFFIX 2: Limit Switch

Pneumatic Spring Return Automated Ball Valve Package

Series 90/93

ASME Class 150 Flanged Ball Valve

- Sizes 1/2" - 12"
- Available in 316SS, WCB or Alloy 20
- ASME Class 150
- Full Port Design
- Superior Live Loaded Packing System
- Blowout Proof Stem w/ Dual Anti-Static Devices
- RTFE Seats Standard
- Pyramidal Stem Seal Design
- Monel Ball & Stem Available

STANDARDS

Design	ASME B16.34 (fully conforms)
Face to Face	ASME B16.10
Flange Dimensions	ASME B16.5
Pressure Testing	API 598
Mounting	ISO 5211
CE Approval	2014/68/EU Module H
Safety Integrity	SIL 3; IEC 61508:2010 (90 Series only)
Material Certification	EN 10204-3.1 MTR
Quality Assurance	ISO 9001:2015
Gas Shut-off Valves	CSA 3.16:21 (6" Series 93 only)



ASME Class 150 Flanged

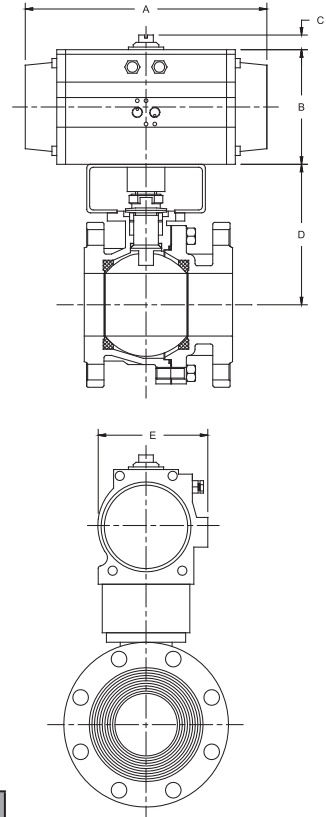

DIMENSIONS (IN)

VALVE SIZE	A	B	C	D	E	VALVE Cv
1/2"	7.60	3.47	0.787	2.91	3.35	15
3/4"	7.60	3.47	0.787	3.20	3.35	45
1"	7.60	3.47	0.787	3.52	3.35	85
1-1/2"	9.29	4.30	0.787	5.05	4.18	275
2"	11.02	4.61	0.787	5.37	4.27	460
2-1/2"	13.39	6.14	0.787	5.80	5.59	700
3"	13.39	6.14	0.787	6.85	5.59	1,100
4"	15.35	6.81	1.181	7.44	5.98	2,200
6"	27.38	10.12	1.181	10.61	9.29	5,150
8"	40.50	10.12	1.181	14.86	9.29	10,000

DIMENSIONS SHOWN ARE FOR ASSEMBLIES SIZED FOR 80 PSI SUPPLY



SERIES 90/93 150# Flanged

SIZED FOR 80 psi AIR SUPPLY	
SIZE	MODEL
1/2"	90-F1-050/3RES-XX
3/4"	90-F1-075/3RES-XX
1"	90-F1-100/3RES-XX
1-1/2"	90-F1-150/3RFS-XX
2"	90-F1-200/3RGS-XX
2-1/2"	90-F1-250/3RJS-XX
3"	90-F1-300/3RJS-XX
4"	90-F1-400/3RKS-XX
6"	93-F1-600/3RTS-XX-A
8"	93-F1-800/3RWS-XX-A

SIZED FOR 60 psi AIR SUPPLY	
SIZE	MODEL
1/2"	90-F1-050/3RE4-XX
3/4"	90-F1-075/3RE4-XX
1"	90-F1-100/3RF4-XX
1-1/2"	90-F1-150/3RG4-XX
2"	90-F1-200/3RG4-XX
2-1/2"	90-F1-250/3RJ4-XX
3"	90-F1-300/3RK4-XX
4"	90-F1-400/3RL4-XX
6"	93-F1-600/3RTS-XX-A
8"	93-F1-800/3RWS-XX-A

OPTIONS

SUFFIX 1	Accessories/Options	Model no.
X	No Specials	
A	TYPE 4 Solenoid 120VAC	TVCS-X411-4N-A120
B	TYPE 7 Solenoid 120VAC	TVC6-X411-7N-A120
C	Intrinsically Safe Solenoid	TVIS-X411-4N-D24
D	TYPE 4 Solenoid 24VDC	TVCS-X411-4N-D24
F	TYPE 7 Solenoid 24VDC	TVC6-X411-7N-D24
Q	TYPE 4 SST Solenoid 120VAC	TVSS-X411-4N-A120
M	TYPE 7 SST Solenoid 120VAC	TVSS-X411-7N-A120
L	TYPE 4 SST Solenoid 24VDC	TVSS-X411-4N-D24
N	TYPE 7 SST Solenoid 24VDC	TVSS-X411-7N-D24
P	Pneumatic Positioner	PPR-1200
E	Electro-Pneumatic Positioner	EPR-1000

SUFFIX 2	Accessories	Model no.
X	No Specials	
A	TYPE 4 Limit Switch	APL-210N
B	TYPE 7 Limit Switch	APL-510N
C	Intrinsically Safe Limit Switch	APL-218N
Q	TYPE 4 SST Limit Switch	APL-910N
M	TYPE 7 SST Limit Switch	APL-510S
H	NEMA 4 Std. Enc.	APL-310N

Other options available - call for details
Actuators are sized based on full differential pressure with clean water. Consult the Application Sizing Guide for assistance with sizing actuators.

Series 90 denotes investment cast / Series 93 denotes sand cast

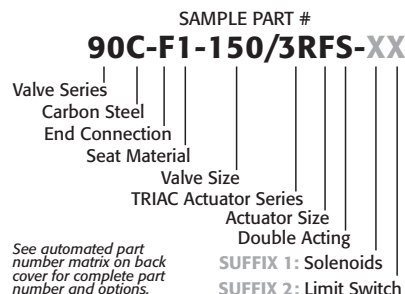

Electric

Automated Ball Valve Package

Series 90/93 ASME Class 150 Flanged Ball Valve

Sizes 1/2" - 12"

Available in 316SST, WCB or Alloy 20

ASME Class 150

Full Port Design

Superior Live Loaded Packing System

Blowout Proof Stem w/ Dual Anti-Static Devices

RTFE Seats Standard

Pyramidal Stem Seal Design

Monel Ball & Stem Available

STANDARDS

Design	ASME B16.34 (fully conforms)
Face to Face	ASME B16.10
Flange Dimensions	ASME B16.5
Pressure Testing	API 598
Mounting	ISO 5211
CE Approval	2014/68/EU Module H
Safety Integrity	SIL 3; IEC 61508:2010 (90 Series only)
Material Certification	EN 10204-3.1 MTR
Quality Assurance	ISO 9001:2015
Gas Shut-off Valves	CSA 3.16:21 (6" Series 93 only)



ASME Class 150 Flanged

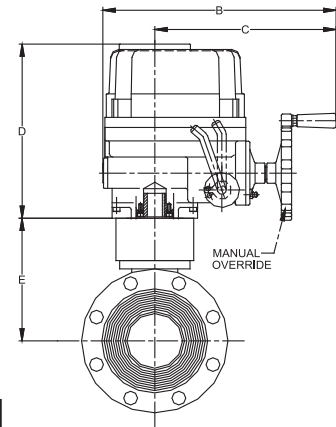
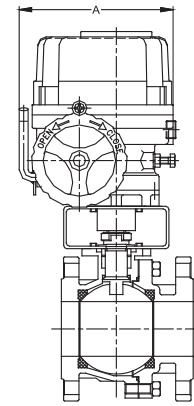

SERIES 90/93 150# Flanged

DIMENSIONS (IN)

VALVE SIZE	A	B	C	D	E	VALVE Cv
1/2"	4.94	4.08	N/A	5.24	2.90	15
3/4"	4.94	4.08	N/A	5.24	3.20	45
1"	4.94	4.08	N/A	5.24	3.52	85
1-1/2"	4.94	4.08	N/A	5.24	5.05	275
2"	4.94	4.08	N/A	5.24	5.37	460
2-1/2"	9.02	13.31	10.43	10.55	5.80	700
3"	9.02	13.31	10.43	10.55	6.85	1,100
4"	9.02	13.31	10.43	10.55	7.44	2,200
6"	11.69	16.14	12.09	12.99	9.96	5,150
8"	12.58	16.14	12.09	22.17	14.86	10,000



ON-OFF	
SIZE	MODEL
1/2"	90-F1-050/WEA1-XX
3/4"	90-F1-075/WEA1-XX
1"	90-F1-100/WEA1-XX
1-1/2"	90-F1-150/WEA1-XX
2"	90-F1-200/WEA1-XX
2-1/2"	90-F1-250/WEC1-XX
3"	90-F1-300/WEC1-XX
4"	90-F1-400/WEC1-XX
6"	93-F1-600/WEH1-XX-A
8"	93-F1-800/WEK1-XX-A

MODULATING	
SIZE	MODEL
1/2"	90-F1-050/WEA2-XX
3/4"	90-F1-075/WEA2-XX
1"	90-F1-100/WEA2-XX
1-1/2"	90-F1-150/WEA2-XX
2"	90-F1-200/WEA2-XX
2-1/2"	90-F1-250/WEC2-XX
3"	90-F1-300/WEC2-XX
4"	90-F1-400/WED2-XX
6"	93-F1-600/WEH2-XX-A
8"	93-F1-800/WEK2-XX-A

OPTIONS	
Suffix 1 Voltage / Accessory	Model No.
X No Specials	
R 24VDC Electric Actuator	
S 220VAC Electric Actuator	
T Other Voltage Electric Actuator	
W 12VDC Electric Actuator	
Y 24VAC Electric Actuator	
* No voltage specified on electric assemblies denotes 120VAC	
Suffix 2 Accessories	
X No Specials	
1 HS1 High Speed Electric	
2 HS2 High Speed Electric	

Other options available - call for details
Actuators are sized based on full differential pressure with clean water. Consult the Application Sizing Guide for assistance with sizing actuators.

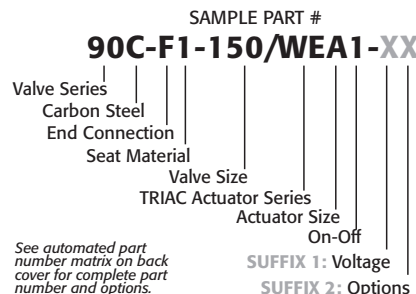

HOW TO ORDER: Manual Valves

2	Valve Series
90	2pc. Flanged Full Port (Investment Cast)

3	Body/Ball/Stem Material
Blank	Valve Series Standard (316SST)
A	Alloy 20 Body, Ball, & Stem
C	Carbon Steel Body
L	Low Carbon 316L Stainless Steel
J	Low Carbon 304 Stainless Steel
H	Carbon Body/Hastelloy Ball & Stem
Q	Carbon Body/Monel Ball & Stem
R	316SST Body/Monel Call & Stem
T	Hastelloy C-276 Body, Ball, & Stem
D	CD3MN Body/Duplex SST Ball & Stem
G	CE3MN Body/Super Duplex SST Ball & Stem
P	CF8 (304SST) Body/304SST Ball & Stem

4	End Connection
F1	150# Flanged Ends

5	Valve Size	
0050	1/2"	0200 2"
0075	3/4"	0250 2 1/2"
0100	1"	0300 3"
0150	1 1/2"	0400 4"

6	Seat, Lining & Trim Materials
X	Reinforced TFE Seats (RTFE)
P	Virgin TFE Seats (PTFE)
U	UHMWPE Seats
S	50/50 STFE Seats
C	25% CS Powder/75% TFE Seats (CTFE)
T	TFM™-1600 Seats
E	All TFM™-1600 Seats, Seals, & Packing
A	50% SS Powder/50% TFM™-1600 Seats (STFM)
F	PTFE Cavity Filler Seats
H	TFM Cavity Filler Seats and Seals
J	STFE Cavity Filler Seats
R	RTFE Cavity Filler Seats

7	Special Designations
X	No Specials/Series Standard
O	Oval Handle (available on some)
4	4" Lockable Stem Extension

8	Additional Specials
X	No Specials, Series Standard
O	Oxygen Cleaned
V	Vented Ball
F	Fugitive Emissions Bonnet
D	Degreased & Bagged
A	Vented Ball, Degreased & Bagged
B	Vented Ball, Oxygen Cleaned

HOW TO ORDER MANUAL VALVES												
2	3	-	4	-	5	-	6	7	8	9	10	11
↓	↓		↓		↓		↓	↓	↓	↓	↓	↓
90	C	-	F1	-	0150	-	X	X	X			

10	O-Ring
X	Multiple Option Designation
2	Markez® Z1028
4	Kalrez 4079
5	Chemraz® 505
6	Kalrez 6375
7	Perlast® G75M
9	Chemraz® 564
B	Low Temp Buna
E	EPDM

11	Additional Specials
Blank	No Designation, Valve Series Standard
X	Multiple Option Designation
B	B7M Bolting
E	CE/PED Certified
M	Marine Epoxy Coating

OPTIONS:

9	Special Designation
Blank	No Designation, Valve Series Standard
X	Multiple Option Designation
A	17-4 PH® Stem
H	Hard Coated (HMF) Ball

17-4 PH® is a registered trademark of AK Steel Corporation.
 Chemraz® is a registered trademark of Greene, Tweed & Co.
 Markez® is a registered trademark of Marco Rubber & Plastic Products Inc.
 Perlast® is a registered trademark of Precision Polymer Engineering Ltd.
 TFM™ is a trademark of Dyneon™, a 3M Company.

Series 93

2	Valve Series
93	2pc. Flanged Full Port (Sand Cast)

3	Body/Ball/Stem Material
Blank	Valve Series Standard (316SST)
C	Carbon Steel Body

4	End Connection
F1	150# Flanged Ends

5	Valve Size
0600	6"
0800	8"
1000	10"
1200	12"

6	Seat, Lining, & Trim Materials
X	Reinforced TFE Seats (RTFE)
P	Virgin TFE Seats (PTFE)
S	50/50 STFE Seats
T	TFM™-1600 Seats

7	Special Designations
X	No Specials/Series Standard
O	Oval Handle (available on some)
4	4" Lockable Stem Extension

8	Additional Specials
X	No Specials, Series Standard

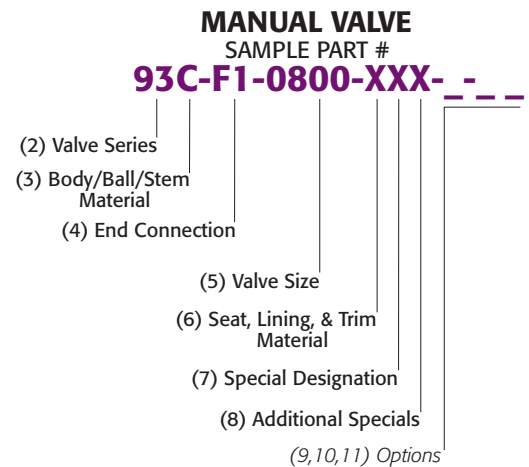

OPTIONS:

9	Special Designation
A	17-4 PH® Stem (Standard)

TFM™ is a trademark of Dyneon™, a 3M Company.

10	O-Ring
Blank	No Designation, Valve Series Standard
X	Multiple Option Designation

11	Additional Specials
Blank	No Designation, Valve Series Standard
X	Multiple Option Designation
B	B7M Bolting
M	Marine Epoxy Coating
C	CSA 3.16 Certified (F90/F88/93 Series)

Series 90

HOW TO ORDER: Automated Valves

2	Valve Series
90	2pc. Flanged Full Port (Investment Cast)

3	Body/Ball/Stem Material
Blank	Valve Series Standard (316SST)
A	Alloy 20 Body, Ball, & Stem
C	Carbon Steel Body
L	Low Carbon 316L Stainless Steel
J	Low Carbon 304 Stainless Steel
H	Carbon Body/Hastelloy Ball & Stem
Q	Carbon Body/Monel Ball & Stem
R	316SST Body/Monel Call & Stem
T	Hastelloy C-276 Body, Ball, & Stem
D	CD3MN Body/Duplex SST Ball & Stem
G	CE3MN Body/Super Duplex SST Ball & Stem
P	CF8 (304SST) Body/304SST Ball & Stem

4	End Connection
F	150# Flanged Ends

5	Seat, Lining & Trim Materials
1	Valve Series Standard Seats (RTFE)
P	Virgin TFE Seats (PTFE)
U	UHMWPE Seats
S	50/50 STFE Seats
C	25% CS Powder/75% TFE Seats (CTFE)
T	TFM™-1600 Seats
E	All TFM™-1600 Seats, Seals, & Packing
A	50% SS Powder/50% TFM™-1600 Seats (STFM)
F	PTFE Cavity Filler Seats
H	TFM Cavity Filler Seats and Seals
J	STFE Cavity Filler Seats
R	RTFE Cavity Filler Seats

6	Valve Size	
050	1/2"	200 2"
075	3/4"	250 2 1/2"
100	1"	300 3"
150	1 1/2"	400 4"

Series 93

2	Valve Series
93	2pc. Flanged Full Port (Sand Cast)

3	Body/Ball/Stem Material
Blank	Valve Series Standard (316SST)
C	Carbon Steel Body

4	End Connection
F	150# Flanged Ends

5	Seat, Lining & Trim Materials
1	Valve Series Standard Seats (RTFE)
P	Virgin TFE Seats (PTFE)
S	50/50 STFE Seats
T	TFM™-1600 Seats

6	Valve Size	
600	6"	1000 10"
800	8"	1200 12"

7 (A) Pneumatic Actuator - 3R, 3N, 3P Series			
3RC	3R10	3RM	3R850
3RD	3R20	3RN	3R1000
3RE	3R40	3RP	3R1200
3RF	3R80	3RR	3R1750
3RG	3R130	3RS	3R2400
3RH	3R200	3RT	3R2500
3RJ	3R300	3RU	3R2700
3RK	3R500	3RV	3R3300
3RL	3R700	3RW	3R3500

3R=Standard, 3N=Electroless Nickel Plating, 3P=Teflon™ (PTFE) Coating

7 (A) Pneumatic Actuator - S2 Series			
S2C	S2-052	S2G	S2-125
S2D	S2-063	S2H	S2-140
S2E	S2-083	S2J	S2-160
S2F	S2-105	S2K	S2-210

7 (B) Pneumatic Action	
D	Double Acting (DA)
S	Spring CW (5 springs)*
O	Spring CCW (5 springs)*
4	Spring CW (4 springs)**
F	Spring CCW (4 springs)**
6	Spring CW (6 springs)
H	Spring CCW (6 springs)

*2500 & 3500 80 psig spring
**2500 & 3500 60 psig spring

7 Actuator - Electric (On-Off)			
WEX1	WE-350	WEG1	WE-5200
WEA1	WE-500	WEH1	WE-6900
WEB1	WE-690	WEJ1	WE-10500
WEC1	WE-1350	WEK1	WE-17500
WED1	WE-1700	WEL1	WE-25900
WEE1	WE-2640	WEM1	WE-53000
WEF1	WE-4400	WEN1	WE-80000

7 Actuator - Electric (Modulating)			
WEA2	WEM-500	WEH2	WEM-6900
WEB2	WEM-690	WEJ2	WEM-10500
WEC2	WEM-1350	WEK2	WEM-17500
WED2	WEM-1700	WEL2	WEM-25900
WEE2	WEM-2640	WEM2	WEM-53000
WEF2	WEM-4400	WEN2	WEM-80000
WEG2	WEM-5200		

OPTIONS:

8	Accessories/Options	Model no.
X	No Specials	
A	TYPE 4 Solenoid 120VAC	TVCS-X411-4N-A120
B	TYPE 7 Solenoid 120VAC	TVCS-X411-7N-A120
C	Intrinsically Safe Solenoid	TVCS-X411-4N-D24
D	TYPE 4 Solenoid 24VDC	TVCS-X411-4N-D24
F	TYPE 7 Solenoid 24VDC	TVCS-X411-7N-D24
Q	TYPE 4 SST Solenoid 120VAC	TVSS-X411-4N-A120
M	TYPE 7 SST Solenoid 120VAC	TVSS-X411-7N-A120
L	TYPE 4 SST Solenoid 24VDC	TVSS-X411-4N-D24
N	TYPE 7 SST Solenoid 24VDC	TVSS-X411-7N-D24
P	Pneumatic Positioner	PPR-1200
E	Electro-Pneumatic Positioner	EPR-1000
R	24VDC Electric Actuator	
S	220VAC Electric Actuator	
T	Other Voltage Electric Actuator	
W	12VDC Electric Actuator	
Y	24VAC Electric Actuator	

* No voltage specified on electric assemblies denotes 120VAC

9	Accessories	Model no.
X	No Specials	
A	TYPE 4 Limit Switch	APL-210N
B	TYPE 7 Limit Switch	APL-510N
C	Intrinsically Safe Limit Switch	APL-218N
Q	TYPE 4 SST Limit Switch	APL-910N
M	TYPE 7 SST Limit Switch	APL-510S
H	NEMA 4 Std. Enc.	APL-310N
1	HS1 High Speed Electric	
2	HS2 High Speed Electric	

10	Special Designation
X	Multiple Option Designation
A	17-4 PH® Stem (Standard on 93 Series)
E	CE/PED Certified
F	Viton® Seal for Pneumatic Actuators (0°F to 300°F)

17-4 PH® is a registered trademark of AK Steel Corporation.
Viton® is a registered trademark of E. I. DuPont de Nemours.
TFM™ is a trademark of Dyneon™, a 3M Company.

AUTOMATED VALVE SAMPLE PART # 90C-F1-150/3RED-XX-

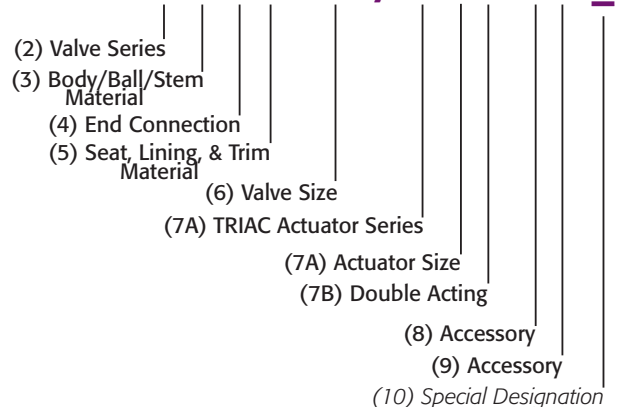

9955 International Blvd. PHONE (513) 247-5465
Cincinnati, Ohio 45246 FAX (513) 247-5462
www.atcontrols.com sales@atcontrols.com