

**API 607 - 6th Edition
CERTIFIED**

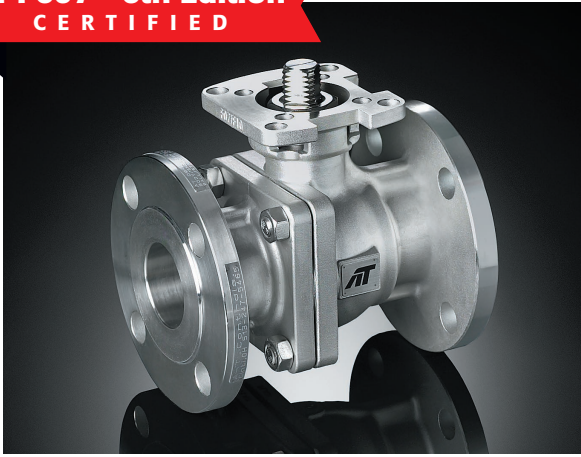

Triac FD9 Series Flanged Ball Valves feature a direct mount automation pad. The high quality investment castings feature a fully machined bore. The superior live-loaded packing system is accomplished with Belleville washers, "V" ring packing and a unique primary pyramidal stem seal. This advanced sealing system provides protection against stem leaks experienced by ordinary ball valves.

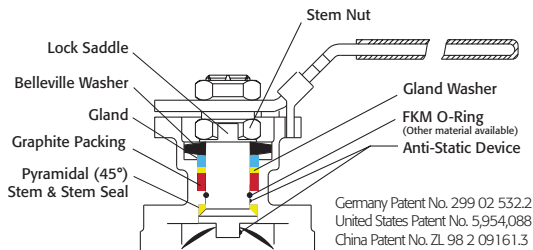

RTFE seats are standard, but various options are available for seat materials. The 50/50 STFE seat option is excellent for services that call for higher temperatures and more difficult applications, including steam. Call us for details.

HOW TO ORDER MANUAL VALVES

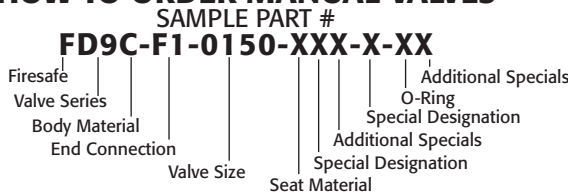

See part number matrix for optimized options.

Easy to Automate!

See automated data sheets for pre-sized assemblies



Pneumatic



Electric

A-T Controls, Inc.

Series FD9

FIRESAFE

**Direct Mount
Split Body
Flanged Ball Valve**

- Sizes 1/2"-12"
- ASME Class 150
- Full Port Design
- Superior Live Loaded Packing System
- ISO 5211 Actuator Mounting Pad
- Blowout Proof Stem w/ Dual Anti-Static Devices
- RTFE Seats Standard
- Pyramidal Stem Seal Design
- Monel Ball & Stem Available
- Lockable Manual Handle

STANDARDS

Design	ASME B16.34 (fully conforms)
Face to Face	ASME B16.10
Flange Dimensions	ASME B16.5
Pressure Testing	API 598
Fire Testing	1/2"-4" (SST & WCB), 6"-12" (WCB only) - API 607-6th Edition 6" (SST) - API-607-4th Edition
Fugitive Emissions	ISO 15848-1
Mounting	ISO 5211
CE Approval	2014/68/EU Module H
Sulfide Stress Protection	NACE MR0175
Safety Integrity	SIL 3; IEC 61508:2010
Material Certification	EN 10204-3.1 MTR
Quality Assurance	ISO 9001:2015

TABLE OF CONTENTS:

- Page 2,3 - Materials & Dimensions
- Page 4 - Technical Data
- Page 5 - Double Acting
- Page 6 - Spring Return
- Page 7 - Electric
- Page 8 - How to Order

SERIES FD9 150# Direct Mount Split Body Flanged Ball Valve

Firesafe

A-T Controls, Inc.

9955 International Blvd.
Cincinnati, Ohio 45246
www.atcontrols.com

PHONE (513) 247-5465
FAX (513) 247-5462
sales@atcontrols.com

Series FD9

High Performance, Full Port Split Body Ball Valve Series FD9 (ASME Class 150)

API 607 - 6th Edition
CERTIFIED

1/2" to 6"

MATERIAL LIST

NO.	PART NAME	QTY	STAINLESS STEEL	CARBON STEEL	REPAIR KIT
1	BODY	1	ASTM A351 GRADE CF8M	ASTM A216 GRADE WCB	
2	END CAP	1	ASTM A351 GRADE CF8M	ASTM A216 GRADE WCB	
3	BALL	1	ASTM A351 GRADE CF8M	ASTM A351 GRADE CF8M	
4	SEAT	2	RTFE	RTFE	✓
5	JOINT GASKET	1	GRAPHITE	GRAPHITE	✓
6	STEM	1	ASTM A276 SS316	ASTM A276 SS316	
7	STEM SEAL	1	TFM™-1600	TFM™-1600	✓
8	GLAND PACKING	1	GRAPHITE	GRAPHITE	✓
9	GLAND WASHER	1	RTFE	RTFE	✓
10	GLAND BUSHING	1	AISI 304	AISI 304	
11	BELLEVILLE WASHER	2	AISI 301	AISI 301	
12	LOCK SADDLE	1	AISI 304	AISI 304	
13	STEM NUT	1	AISI 304	AISI 304	
14	STEM WASHER	1	AISI 304	AISI 304	
15	HANDLE	1	AISI 304	AISI 304	
16	HANDLE SLEEVE	1	VINYL	VINYL	
17	BODY NUT	*	ASTM A194 GRADE 8M	ASTM A194 GRADE 2HM	
18	BODY STUD	*	ASTM A193 GRADE B8M	ASTM A193 GRADE B7M	
19	STOP BOLT	1	AISI 304	AISI 304	
20	STOP BOLT NUT	1	AISI 304	AISI 304	
21	HANDLE LOCK	1	AISI 304	AISI 304	
22	STEM O-RING	1	FKM	FKM	✓
23	ANTI-STATIC DEVICE	2	AISI 316	AISI 316	
24	HANDLE NUT	1	AISI 304	AISI 304	

* 1/2" THRU 2" QTY = 4 PCS
* 2-1/2" THRU 4" QTY = 8 PCS

*6" QTY = 10 PCS

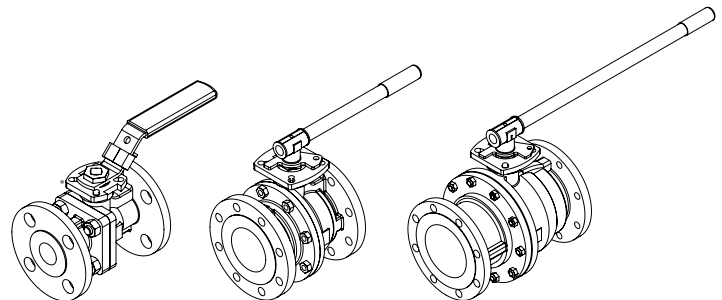
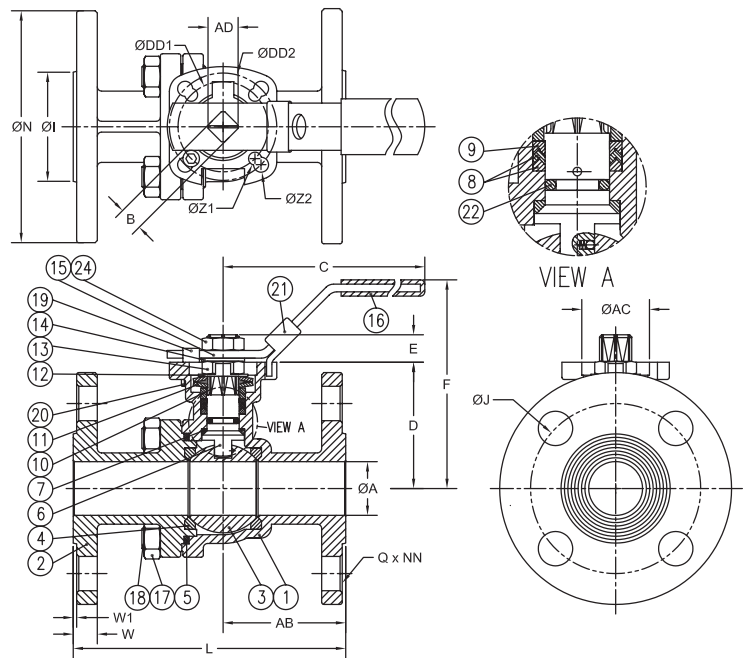

BENT HANDLE SIZES 1/2" - 2-1/2"
PIPE HANDLE SIZES 3" - 4"
PIPE HANDLE SIZE 6"

NOTE: A-T CONTROLS RECOMMENDS A GEAR FOR 6" VALVES AND LARGER

DIMENSIONS (IN)

SIZE	A	B	C	D	E	F	I	J	L	N	Q	W	W1	Z1	Z2	AB	AC	AD	DD1	DD2	NN	ISO 5211	(LBS)
1/2"	0.59	0.433	6.50	1.84	0.39	3.30	1.38	2.38	4.26	3.50	0.63	0.44	0.06	0.26	0.28	1.84	1.26	0.55	1.654	1.969	4	F04/F05	4.0
3/4"	0.79	0.433	6.50	2.02	0.39	3.45	1.69	2.74	4.62	3.88	0.63	0.44	0.06	0.26	0.28	2.18	1.26	0.55	1.654	1.969	4	F04/F05	5.0
1"	0.98	0.433	6.50	2.31	0.41	3.81	2.00	3.12	5.00	4.25	0.63	0.44	0.06	0.26	0.28	2.21	1.26	0.55	1.654	1.969	4	F04/F05	7.0
1-1/2"	1.50	0.748	10.32	3.51	0.75	5.60	2.88	3.88	6.50	5.00	0.63	0.56	0.06	0.39	0.47	2.83	2.09	0.94	2.756	4.016	4	F07/F10	14.5
2"	1.97	0.748	10.32	3.80	0.75	5.78	3.62	4.75	7.02	6.00	0.75	0.63	0.06	0.39	0.47	3.38	2.09	0.94	2.756	4.016	4	F07/F10	20.5
2-1/2"	2.56	0.748	10.32	4.57	0.75	6.75	4.12	5.50	7.48	7.00	0.75	0.69	0.06	0.39	0.47	3.06	2.09	0.94	2.756	4.016	4	F07/F10	31.0
3"	3.15	0.866	14.37	5.22	0.91	8.05	5.00	6.00	8.01	7.50	0.75	0.75	0.06	0.47	0.55	4.01	2.55	1.18	4.016	4.921	4	F10/F12	41.0
4"	3.94	0.866	14.37	6.18	0.91	9.00	6.19	7.50	9.00	9.00	0.75	0.94	0.06	0.47	0.55	4.07	2.55	1.18	4.016	4.921	8	F10/F12	67.5
6"	5.91	1.063	29.53	8.28	1.12	12.50	8.50	9.50	15.50	11.0	0.87	1.00	0.06	0.55	0.71	7.00	2.97	1.41	4.921	5.511	8	F12/F14	145.0

Series FD9

High Performance, Full Port Split Body Ball Valve Series FD9 (ASME Class 150)

API 607 - 6th Edition
CERTIFIED

Pressure vs. Temperature - Series D9/FD9-F1
Seat Pressure Ratings

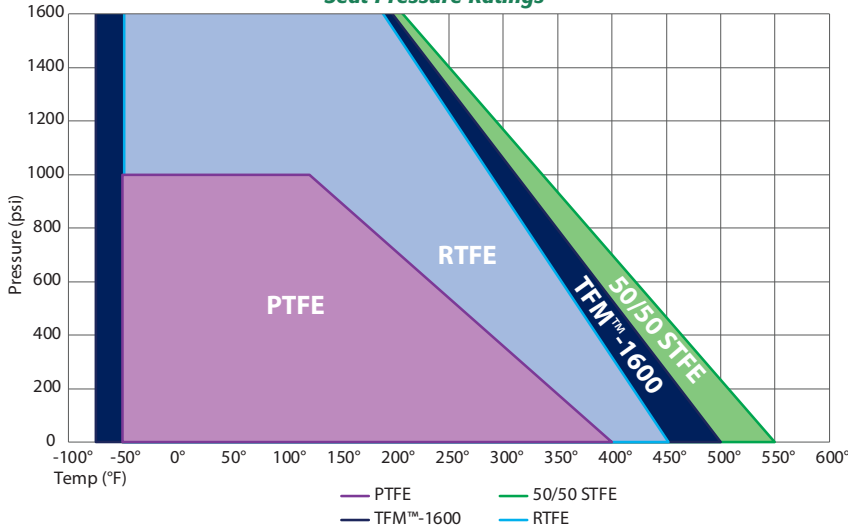

Temp	Pressure - Seat Material			
	RTFE	STFE	PTFE	TFM™-1600
-75°				2000
-50°	2000	2000	1000	2000
100°	2000	2000	1000	2000
122°	2000	2000	1000	2000
150°	1829	1869	899	1852
200°	1524	1636	719	1587
250°	1220	1402	540	1323
300°	915	1168	360	1058
350°	610	935	180	794
400°	305	701	0	529
450°	0	467		265
500°		234		0
550°		0		

Pressure vs. Temperature - Series D9/FD9-F1
Body & End Cap Ratings ASME B16.34

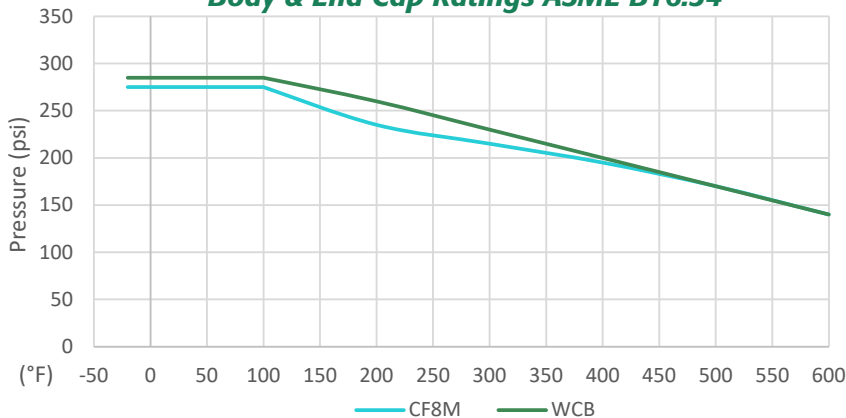

Temp (°F)	WCB psi	CF8M psi
-20°	285	275
100°	285	275
200°	260	235
300°	230	215
400°	200	195
500°	170	170
600°	140	140

Component Temperature Ratings		
COMPONENT	MATERIAL	TEMPERATURE
Stem Packing	Graphite	-100°F to 1100°F
Stem Seal	TFM™-1600	-75°F to 500°F
Gaskets	Graphite	-100°F to 1100°F
Seats (Other Materials Available)	PTFE	-50°F to 400°F
	RTFE (standard)	-50°F to 450°F
	TFM™-1600	-75°F to 500°F
	50/50 STFE	-50°F to 550°F
O-Rings	FKM (standard)	-20°F to 450°F
	Markez® Z1028	5°F to 608°F
	Kalrez® 4079	30°F to 600°F
	Chemraz® 505	-22°F to 446°F
	Kalrez® 6375	-4°F to 527°F
	Perlast® G75M	5°F to 500°F
	Chemraz® 564	-40°F to 445°F
	Low Temp Buna	-65°F to 275°F
	EPDM	-70°F to 250°F
	Silicone	-60°F to 400°F

NOTE: At temperature, valves are limited by either the valve body/end cap pressure ratings, seat pressure ratings, or packing/stem seal/gaskets; whichever is lower.

Break Away Torque for RTFE Seats	
SIZE	IN-LBS.
1/2"	45
3/4"	73
1"	91
1-1/2"	230
2"	297
2-1/2"	535
3"	768
4"	1,250
6"	3,000
8"	6,500
10"	13,000*
12"	26,000*

Published torques are based on full differential pressure with clean water. Consult the Application Sizing Guide for assistance with sizing actuators.

*NOTE: 10" & 12" torques are at 100 psig with clean, lubricating fluid. Please consult factory for torques at full differential pressure.

SIZE	Cv
1/2"	15
3/4"	45
1"	85
1-1/2"	275
2"	460
2-1/2"	700
3"	1,100
4"	2,200
6"	5,150
8"	10,000
10"	16,400
12"	23,800

Pneumatic Double Acting Automated Ball Valve Package

Series FD9
ASME Class 150
Flanged Ball Valve
Direct Mount

Firesafe

Sizes 1/2" - 12"

ASME Class 150

Full Port Design

Superior Live Loaded Packing System

Blowout Proof Stem w/ Dual Anti-Static Devices

RTFE Seats Standard

Pyramidal Stem Seal Design

Monel Ball & Stem Available

STANDARDS

Design	ASME B16.34 (fully conforms)
Face to Face	ASME B16.10
Flange Dimensions	ASME B16.5
Pressure Testing	API 598
Fire Testing	
	1/2"-4" (SST & WCB), 6"-12" (WCB only) - API 607-6th Edition
	6" (SST) - API-607-4th Edition
Fugitive Emissions	ISO 15848-1
Mounting	ISO 5211
CE Approval	2014/68/EU Module H
Sulfide Stress Protection	NACE MR0175
Safety Integrity	SIL 3; IEC 61508:2010
Material Certification	EN 10204-3.1 MTR
Quality Assurance	ISO 9001:2015

API 607 - 6th Edition
CERTIFIED



ASME Class 150
Firesafe Tested to API-607
Direct Mount

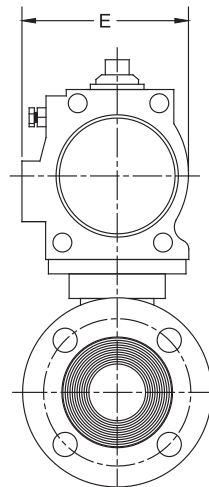
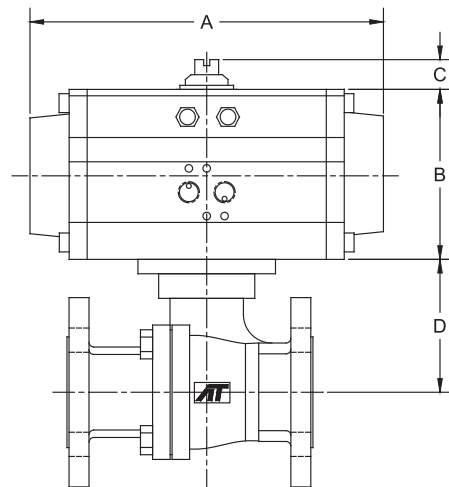

DIMENSIONS (IN)

VALVE SIZE	A	B	C	D	E	VALVE Cv
1/2"	6.50	2.84	0.787	1.84	2.82	15
3/4"	6.50	2.84	0.787	2.02	2.82	45
1"	6.50	2.84	0.787	2.31	2.82	85
1-1/2"	9.29	4.30	0.787	3.51	4.18	275
2"	9.29	4.30	0.787	3.80	4.18	450
2-1/2"	9.29	4.30	0.787	4.57	4.18	700
3"	13.39	6.14	0.787	5.22	5.59	1100
4"	13.39	6.14	0.787	6.18	5.59	2200
6"	15.35	6.811	1.181	8.28	5.98	5150

DIMENSIONS SHOWN ARE FOR ASSEMBLIES SIZED FOR 80 PSI SUPPLY

SERIES FD9 150# Flanged Direct Mount

Firesafe

SIZED FOR 80 psi AIR SUPPLY	
SIZE	MODEL
1/2"	FD9-F1-050/3RDD-XX
3/4"	FD9-F1-075/3RDD-XX
1"	FD9-F1-100/3RDD-XX
1-1/2"	FD9-F1-150/3RFD-XX
2"	FD9-F1-200/3RFD-XX
2-1/2"	FD9-F1-250/3RFD-XX
3"	FD9-F1-300/3RJD-XX
4"	FD9-F1-400/3RJD-XX
6"	FD9-F1-600/3RKD-XX

SIZED FOR 60 psi AIR SUPPLY	
SIZE	MODEL
1/2"	FD9-F1-050/3RDD-XX
3/4"	FD9-F1-075/3RDD-XX
1"	FD9-F1-100/3RDD-XX
1-1/2"	FD9-F1-150/3RFD-XX
2"	FD9-F1-200/3RFD-XX
2-1/2"	FD9-F1-250/3RFD-XX
3"	FD9-F1-300/3RJD-XX
4"	FD9-F1-400/3RJD-XX
6"	FD9-F1-600/3RKD-XX

OPTIONS		
SUFFIX 1	Accessories/Options	Model no.
X	No Specials	
A	TYPE 4 Solenoid 120VAC	TVCS-X411-4N-A120
B	TYPE 7 Solenoid 120VAC	TVC6-X411-7N-A120
C	Intrinsically Safe Solenoid	TVIS-X411-4N-D24
D	TYPE 4 Solenoid 24VDC	TVCS-X411-4N-D24
F	TYPE 7 Solenoid 24VDC	TVC6-X411-7N-D24
Q	TYPE 4 SST Solenoid 120VAC	TVSS-X411-4N-A120
M	TYPE 7 SST Solenoid 120VAC	TVSS-X411-7N-A120
L	TYPE 4 SST Solenoid 24VDC	TVSS-X411-4N-D24
N	TYPE 7 SST Solenoid 24VDC	TVSS-X411-7N-D24
P	Pneumatic Positioner	PPR-1200
E	Electro-Pneumatic Positioner	EPR-1000
SUFFIX 2	Accessories	Model no.
X	No Specials	
A	TYPE 4 Limit Switch	APL-210N
B	TYPE 7 Limit Switch	APL-510N
C	Intrinsically Safe Limit Switch	APL-218N
Q	TYPE 4 SST Limit Switch	APL-910N
M	TYPE 7 SST Limit Switch	APL-510S
H	NEMA 4 Std. Enc.	APL-310N

Other options available - call for details.
Actuators are sized based on full differential pressure with clean water. Consult the Application Sizing Guide for assistance with sizing actuators.

SAMPLE PART #
FD9C-F1-150/3RFD-XX

Firesafe |
Valve Series |
Carbon Steel |
End Connection |
Seat Material |
Valve Size |
TRIAC Actuator Series |
Actuator Size |
Double Acting |

See automated part number matrix on back cover for complete part number and options.

SUFFIX 1: Solenoids
SUFFIX 2: Limit Switch

Pneumatic Spring Return Automated Ball Valve Package

Series FD9
ANSI Class 150
Flanged Ball Valve
Direct Mount

- Firesafe
- Sizes 1/2" - 12"
- ASME Class 150
- Full Port Design
- Superior Live Loaded Packing System
- Blowout Proof Stem w/ Dual Anti-Static Devices
- RTFE Seats Standard
- Pyramidal Stem Seal Design
- Monel Ball & Stem Available

STANDARDS

Design	ASME B16.34 (fully conforms)
Face to Face	ASME B16.10
Flange Dimensions	ASME B16.5
Pressure Testing	API 598
Fire Testing	1/2"-4" (SST & WCB), 6"-12" (WCB only) - API 607-6th Edition 6" (SST) - API-607-4th Edition
Fugitive Emissions	ISO 15848-1
Mounting	ISO 5211
CE Approval	2014/68/EU Module H
Sulfide Stress Protection	NACE MR0175
Safety Integrity	SIL 3; IEC 61508:2010
Material Certification	EN 10204-3.1 MTR
Quality Assurance	ISO 9001:2015

**API 607 - 6th Edition
CERTIFIED**



ASME Class 150
Firesafe Tested to API-607
Direct Mount

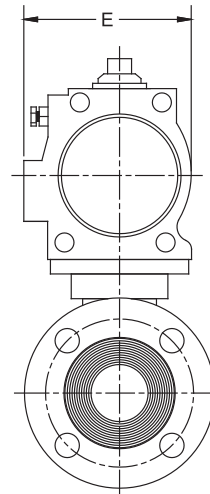
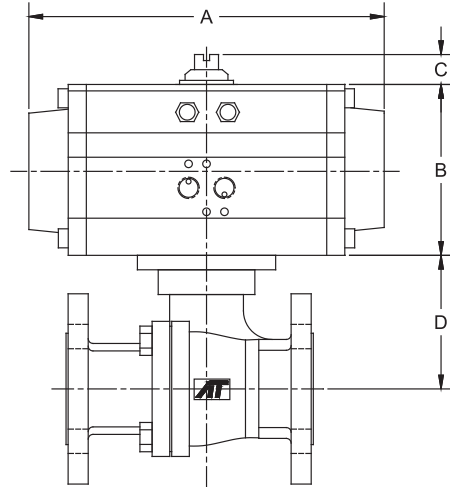

DIMENSIONS (IN)

VALVE SIZE	A	B	C	D	E	VALVE Cv
1/2"	7.60	3.47	0.787	1.84	3.35	15
3/4"	7.60	3.47	0.787	2.02	3.35	45
1"	7.60	3.47	0.787	2.31	3.35	85
1-1/2"	9.29	4.30	0.787	3.51	4.18	275
2"	11.02	4.61	0.787	3.80	4.27	450
2-1/2"	11.50	5.28	0.787	4.57	5.78	700
3"	15.35	6.81	1.181	5.22	5.98	1100
4"	15.35	6.81	1.181	6.18	5.98	2200
6"	22.36	9.06	1.181	8.28	8.11	5150

DIMENSIONS SHOWN ARE FOR ASSEMBLIES SIZED FOR 80 PSI SUPPLY

SERIES FD9 150# Flanged Direct Mount

Firesafe

SIZED FOR 80 psi AIR SUPPLY	
SIZE	MODEL
1/2"	FD9-F1-050/3RES-XX
3/4"	FD9-F1-075/3RES-XX
1"	FD9-F1-100/3RES-XX
1-1/2"	FD9-F1-150/3RFS-XX
2"	FD9-F1-200/3RGS-XX
2-1/2"	FD9-F1-250/3RHS-XX
3"	FD9-F1-300/3RKS-XX
4"	FD9-F1-400/3RKS-XX
6"	FD9-F1-600/3RPS-XX

SIZED FOR 60 psi AIR SUPPLY	
SIZE	MODEL
1/2"	FD9-F1-050/3RE4-XX
3/4"	FD9-F1-075/3RE4-XX
1"	FD9-F1-100/3RF4-XX
1-1/2"	FD9-F1-150/3RG4-XX
2"	FD9-F1-200/3RG4-XX
2-1/2"	FD9-F1-250/3RJ4-XX
3"	FD9-F1-300/3RK4-XX
4"	FD9-F1-400/3RL4-XX
6"	FD9-F1-600/3RR4-XX

OPTIONS

SUFFIX 1	Accessories/Options	Model no.
X	No Specials	
A	TYPE 4 Solenoid 120VAC	TVCS-X411-4N-A120
B	TYPE 7 Solenoid 120VAC	TVCS-X411-7N-A120
C	Intrinsically Safe Solenoid	TVIS-X411-4N-D24
D	TYPE 4 Solenoid 24VDC	TVCS-X411-4N-D24
F	TYPE 7 Solenoid 24VDC	TVCS-X411-7N-D24
Q	TYPE 4 SST Solenoid 120VAC	TVSS-X411-4N-A120
M	TYPE 7 SST Solenoid 120VAC	TVSS-X411-7N-A120
L	TYPE 4 SST Solenoid 24VDC	TVSS-X411-4N-D24
N	TYPE 7 SST Solenoid 24VDC	TVSS-X411-7N-D24
P	Pneumatic Positioner	PPR-1200
E	Electro-Pneumatic Positioner	EPR-1000
SUFFIX 2	Accessories	Model no.
X	No Specials	
A	TYPE 4 Limit Switch	APL-210N
B	TYPE 7 Limit Switch	APL-510N
C	Intrinsically Safe Limit Switch	APL-218N
Q	TYPE 4 SST Limit Switch	APL-910N
M	TYPE 7 SST Limit Switch	APL-510S
H	NEMA 4 Std. Enc.	APL-310N

Other options available - call for details.
Actuators are sized based on full differential pressure with clean water. Consult the Application Sizing Guide for assistance with sizing actuators.

SAMPLE PART # FD9C-F1-150/3RGS-XX

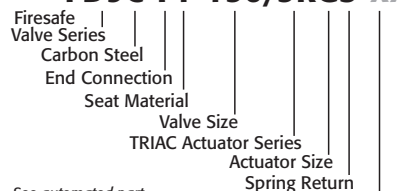

See automated part number matrix on back cover for complete part number and options.

SUFFIX 1: Solenoids
SUFFIX 2: Limit Switch

Electric

Automated Ball Valve Package

Series FD9
ASME Class 150
Flanged Ball Valve
Direct Mount

- Firesafe
- Sizes 1/2"-12"
- ASME Class 150
- Full Port Design
- Superior Live Loaded Packing System
- Blowout Proof Stem w/ Dual Anti-Static Devices
- RTFE Seats Standard
- Pyramidal Stem Seal Design
- Monel Ball & Stem Available

STANDARDS

Design	ASME B16.34 (fully conforms)
Face to Face	ASME B16.10
Flange Dimensions	ASME B16.5
Pressure Testing	API 598
Fire Testing	
1/2"-4" (SST & WCB), 6"-12" (WCB only) - API 607-6th Edition	
6" (SST) - API-607-4th Edition	
Fugitive Emissions	ISO 15848-1
Mounting	ISO 5211
CE Approval	2014/68/EU Module H
Sulfide Stress Protection	NACE MR0175
Safety Integrity	SIL 3; IEC 61508:2010
Material Certification	EN 10204-3.1 MTR
Quality Assurance	ISO 9001:2015

**API 607 - 6th Edition
CERTIFIED**



ASME Class 150
Firesafe Tested to API-607
Direct Mount

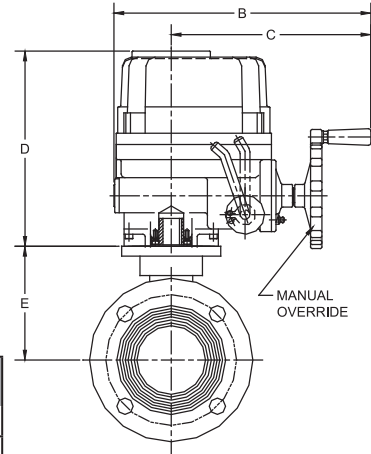
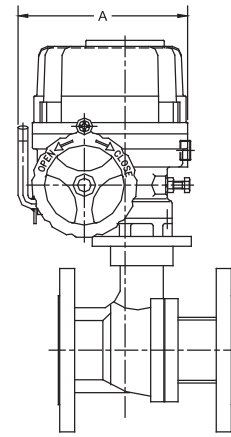

DIMENSIONS (IN)

VALVE SIZE	A	B	C	D	E	VALVE Cv
1/2"	4.98	4.08	N/A	5.24	1.84	15
3/4"	4.98	4.08	N/A	5.24	2.02	45
1"	4.98	4.08	N/A	5.24	2.31	85
1-1/2"	4.98	4.08	N/A	5.24	3.51	275
2"	4.98	4.08	N/A	5.24	3.80	450
2-1/2"	9.02	13.31	8.19	10.55	4.57	700
3"	9.02	13.31	8.19	10.55	5.22	1,100
4"	10.20	14.49	10.43	11.42	6.18	2,200
6"	10.20	14.49	11.26	11.97	8.28	5,150

SERIES FD9 150# Flanged Direct Mount Firesafe

ON-OFF	
SIZE	MODEL
1/2"	FD9-F1-050/WEA1-XX
3/4"	FD9-F1-075/WEA1-XX
1"	FD9-F1-100/WEA1-XX
1-1/2"	FD9-F1-150/WEA1-XX
2"	FD9-F1-200/WEA1-XX
2-1/2"	FD9-F1-250/WEC1-XX
3"	FD9-F1-300/WEC1-XX
4"	FD9-F1-400/WEE1-XX
6"	FD9-F1-600/WEF1-XX

MODULATING	
SIZE	MODEL
1/2"	FD9-F1-050/WEA2-XX
3/4"	FD9-F1-075/WEA2-XX
1"	FD9-F1-100/WEA2-XX
1-1/2"	FD9-F1-150/WEA2-XX
2"	FD9-F1-200/WEA2-XX
2-1/2"	FD9-F1-250/WEC2-XX
3"	FD9-F1-300/WEC2-XX
4"	FD9-F1-400/WEE2-XX
6"	FD9-F1-600/WEF2-XX

OPTIONS

Suffix 1	Voltage / Accessory	Model No.
X	No Specials	
R	24VDC Electric Actuator	
S	220VAC Electric Actuator	
T	Other Voltage Electric Actuator	
W	12VDC Electric Actuator	
Y	24VAC Electric Actuator	

* No voltage specified on electric assemblies denotes 120VAC

Suffix 2 Accessories

X	No Specials
1	HS1 High Speed Electric
2	HS2 High Speed Electric

Other options available - call for details
Actuators are sized based on full differential pressure with clean water. Consult the Application Sizing Guide for assistance with sizing actuators.

SAMPLE PART # FD9C-F1-150/WEA1-XX

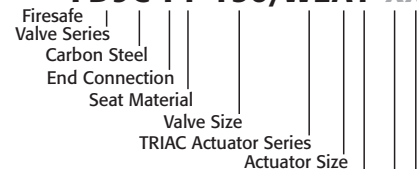

See automated part number matrix on back cover for complete part number and options.

On-Off
SUFFIX 1: Voltage
SUFFIX 2: Options

Series FD9 HOW TO ORDER: Manual Valves

1	Prefix
F	Firesafe Tested (see valve series for details & testing)
2	Valve Series
D9	Direct Mount Flanged
3	Body/Ball/Stem Material
Blank	Valve Series Standard (316SST)
C	Carbon Steel Body
L	Low Carbon 316L Stainless Steel
Q	Carbon Body/Monel Ball & Stem
R	316 SST Body/Monel Ball & Stem
4	End Connection
F1	150# Flanged Ends
5	Valve Size
0050	1/2" 0300 3"
0075	3/4" 0400 4"
0100	1" 0600 6"
0150	1-1/2" 0800 8"
0200	2" 1000 10"
0250	2-1/2" 1200 12"

6	Seat, Lining & Trim Materials
X	Reinforced TFE Seats (RTFE)
P	Virgin TFE Seats (PTFE)
U	UHMWPE Seats
S	50/50 STFE Seats
C	25% CS Powder/75% TFE Seats (CTFE)
T	TFM™-1600 Seats
A	50% SS Powder / 50% TFM™-1600 Seats (STFM)
F	PTFE Cavity Filler Seats
H	TFM Cavity Filler Seats and Seals
J	STFE Cavity Filler Seats
R	RTFE Cavity Filler Seats
M	MG1241 Seats
Z	PEEK Seats

7	Special Designation
X	No Specials/Series Standard
G	Gear Operator
H	Gear Operator with Lockout Plate
O	Oval Handle (available in some)
S	Spring Return (Direct Mount Only)
4	4" Lockable Stem Extension

8	Additional Specials
X	No Specials, Series Standard
O	Oxygen Cleaned
V	Vented Ball
E	Bonnet Extension Lockable Handle
D	Degreased & Bagged
A	Vented Ball, Degreased & Bagged
B	Vented Ball, Oxygen Cleaned

9	Special Designation
Blank	No Designation, Valve Series Standard
X	Multiple Option Designation
A	17-4 PH® Stem
H	Hard Coated (HMF) Ball

10	O-Ring
X	Multiple Option Designation
2	Markez® Z1028
4	Kalrez 4079
5	Chemraz 505
6	Kalrez 6375
7	Perlast® G75M
9	Chemraz® 564
B	Low Temp Buna
E	EPDM

11	Additional Specials
X	Multiple Option Designation
B	B7M Bolting
E	CE/PED Certified
M	Marine Epoxy Coating

HOW TO ORDER MANUAL VALVES

1 2 3 - 4 - 5 - 6 7 8 - 9 - 10 11
 ↓ ↓ ↓ ↓ ↓ ↓ ↓ ↓ ↓ ↓ ↓ ↓
F D9 C - F1 - 0150 - X X X

17-4 PH® is a registered trademark of AK Steel Corporation.
 Chemraz® is a registered trademark of Greene, Tweed & Co.
 TFM™ is a trademark of Dyneon™, a 3M Company.
 Perlast® is a registered trademark of Precision Polymer Engineering Limited.
 Markez® is a registered trademark of Marco Rubber & Plastic Products Inc..

HOW TO ORDER: Automated Valves

1	Prefix
F	Firesafe Tested (see valve series for details & testing)
NS	NSF 61 & 372 Certified Series
2	Valve Series
D9	Direct Mount Flanged
3	Body/Ball/Stem Material
Blank	Valve Series Standard (316SST)
A	Alloy 20 Body, Ball, & Stem
C	Carbon Steel Body
L	Low Carbon 316L Stainless Steel
H	Carbon Body / Hastelloy Ball & Stem
Q	Carbon Body/Monel Ball & Stem
R	316 SST Body/Monel Ball & Stem
4	End Connection
F	150# Flanged Ends
5	Seat, Lining & Trim Materials
1	Valve Series Standard Seats (RTFE)
P	Virgin TFE Seats (PTFE)
U	UHMWPE Seats
S	50/50 STFE Seats
C	25% CS Powder/75% TFE Seats (CTFE)
T	TFM™-1600 Seats
A	50% SS Powder / 50% TFM™-1600 Seats (STFM)
F	PTFE Cavity Filler Seats
H	TFM Cavity Filler Seats and Seals
J	STFE Cavity Filler Seats
R	RTFE Cavity Filler Seats
M	MG1241 Seats
Z	PEEK Seats
6	Valve Size
050	1/2" 200 2" 600 6"
075	3/4" 250 2-1/2" 800 8"
100	1" 300 3" AAA 10"
150	1-1/2" 400 4" BBB 12"

7 (A) Pneumatic Actuator - 3R, 3N, 3P Series
3RC 3R10 3RM 3R850
3RD 3R20 3RN 3R1000
3RE 3R40 3RP 3R1200
3RF 3R80 3RR 3R1750
3RG 3R130 3RS 3R2400
3RH 3R200 3RT 3R2500
3RJ 3R300 3RU 3R2700
3RK 3R500 3RV 3R3300
3RL 3R700 3RW 3R3500

3R=Standard, 3N=Electroless Nickel Plating,
 3P=Teflon™ (PTFE) Coating

7 (A) Pneumatic Actuator - S2 Series
S2C S2-052 S2G S2-125
S2D S2-063 S2H S2-140
S2E S2-083 S2J S2-160
S2F S2-105 S2K S2-210

7 (B) Pneumatic Action
D Double Acting (DA)
S Spring CW (5 springs)*
O Spring CCW (5 springs)*
4 Spring CW (4 springs)**
F Spring CCW (4 springs)**
6 Spring CW (6 springs)
H Spring CCW (6 springs)

*2500 & 3500 80 psig spring
 **2500 & 3500 60 psig spring

7 Actuator - Electric (On-Off)
WEX1 WE-350 WEG1 WE-5200
WEA1 WE-500 WEH1 WE-6900
WEB1 WE-690 WEJ1 WE-10500
WEC1 WE-1350 WEK1 WE-17500
WED1 WE-1700 WEL1 WE-25900
WEE1 WE-2640 WEM1 WE-53000
WEF1 WE-4400 WEN1 WE-80000

7 Actuator - Electric (Modulating)
WEA2 WEM-500 WEH2 WEM-6900
WEB2 WEM-690 WEJ2 WEM-10500
WEC2 WEM-1350 WEK2 WEM-17500
WED2 WEM-1700 WEL2 WEM-25900
WEE2 WEM-2640 WEM2 WEM-53000
WEF2 WEM-4400 WEN2 WEM-80000
WEG2 WEM-5200

AUTOMATED VALVE

SAMPLE PART #

FD9C-F1-150/3RFD-XX-

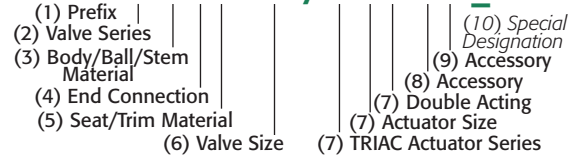

8 Accessories/Options	Model no.
X	No Specials
A	TYPE 4 Solenoid 120VAC TVCS-X411-4N-A120
B	TYPE 7 Solenoid 120VAC TVC6-X411-7N-A120
C	Intrinsically Safe Solenoid TVIS-X411-4N-D24
D	TYPE 4 Solenoid 24VDC TVCS-X411-4N-D24
F	TYPE 7 Solenoid 24VDC TVC6-X411-7N-D24
Q	TYPE 4 SST Solenoid 120VAC TVSS-X411-4N-A120
M	TYPE 7 SST Solenoid 120VAC TVSS-X411-7N-A120
L	TYPE 4 SST Solenoid 24VDC TVSS-X411-4N-D24
N	TYPE 7 SST Solenoid 24VDC TVSS-X411-7N-D24
P	Pneumatic Positioner PPR-1200
E	Electro-Pneumatic Positioner EPR-1000
R	24VDC Electric Actuator
S	220VAC Electric Actuator
T	Other Voltage Electric Actuator
W	12VDC Electric Actuator
Y	24VAC Electric Actuator

* No voltage specified on electric assemblies denotes 120VAC

9 Accessories	Model no.
X	No Specials
A	TYPE 4 Limit Switch APL-210N
B	TYPE 7 Limit Switch APL-510N
C	Intrinsically Safe Limit Switch APL-218N
Q	TYPE 4 SST Limit Switch APL-910N
M	TYPE 7 SST Limit Switch APL-510S
H	NEMA 4 Std. Enc. APL-310N
1	HS1 High Speed Electric
2	HS2 High Speed Electric

10 Special Designation	
Blank	No Designation, Valve Series Standard
X	Multiple Option Designation
A	17-4 PH® Stem
E	CE/PED Certified
F	Viton® Seal for Pneumatic Actuators (0°F to 300°F)



9955 International Blvd. PHONE (513) 247-5465
 Cincinnati, Ohio 45246 FAX (513) 247-5462
 www.atcontrols.com sales@atcontrols.com